

OZITO

PETROL TILLER

51.7 cc 2 HP

INSTRUCTION MANUAL

SPECIFICATIONS

Engine:	51,7cc 2 Stroke, Air Cooled
Power:	1.5kw (2HP)
Fuel & Oil Mix:	40:1
Fuel Tank Capacity:	1000ml
Starter Type:	Recoil
No Load Speed	
Idle:	3000 ±300 rpm
Max.:	8600 rpm
Tilling Width:	250-300mm
Tilling Depth:	60-100mm
Net Weight:	16kgs

ozito.com.au

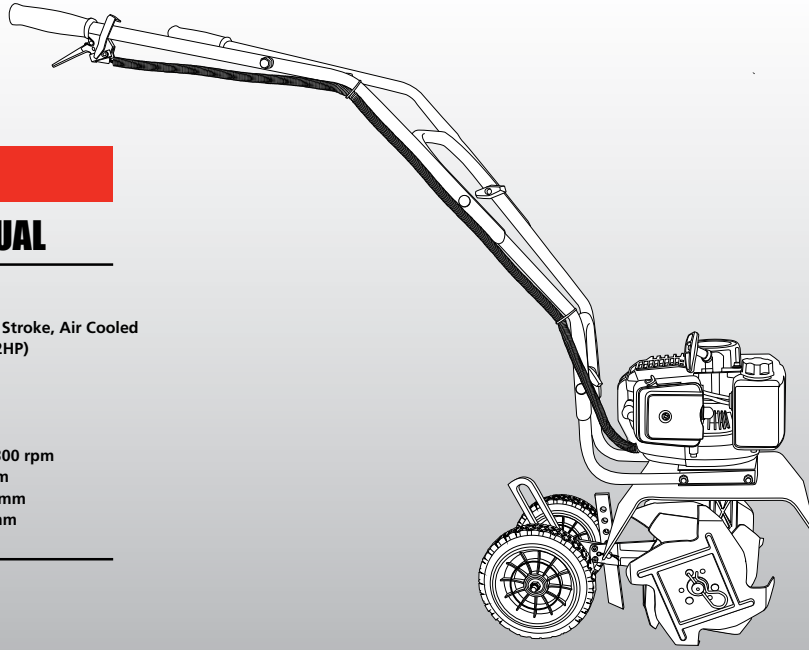

WHAT'S IN THE BOX

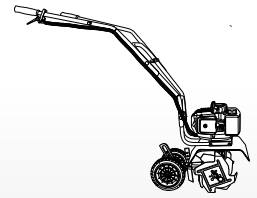

Petrol Tiller

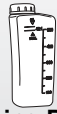

Fuel Mixing Bottle



Spark Plug Spanner



Spanners, Hex Wrench & Cable Clips



Handle Lock Knob & Bolt Set x4, Bolt & Nut Set x 2

1 YEAR REPLACEMENT WARRANTY

PTL-4300

WARRANTY

IN ORDER TO MAKE A CLAIM UNDER THIS WARRANTY YOU MUST RETURN THE PRODUCT TO YOUR NEAREST BUNNINGS WAREHOUSE WITH YOUR BUNNINGS REGISTER RECEIPT. PRIOR TO RETURNING YOUR PRODUCT FOR WARRANTY PLEASE TELEPHONE OUR CUSTOMER SERVICE HELPLINE:

Australia 1800 069 486

New Zealand 0508 069 486

TO ENSURE A SPEEDY RESPONSE PLEASE HAVE THE MODEL NUMBER AND DATE OF PURCHASE AVAILABLE. A CUSTOMER SERVICE REPRESENTATIVE WILL TAKE YOUR CALL AND ANSWER ANY QUESTIONS YOU MAY HAVE RELATING TO THE WARRANTY POLICY OR PROCEDURE.

The benefits provided under this warranty are in addition to other rights and remedies which are available to you at law.

Our goods come with guarantees that cannot be excluded at law. You are entitled to a replacement or refund for a major failure and for compensation for any other reasonably foreseeable loss or damage. You are also entitled to have the goods repaired or replaced if the goods fail to be of acceptable quality and the failure does not amount to a major failure.

Generally you will be responsible for all costs associated with a claim under this warranty, however, where you have suffered any additional direct loss as a result of a defective product you may be able to claim such expenses by contacting our customer service helpline above.

1 YEAR WARRANTY

Your product is guaranteed for a period of **12 months from the original date of purchase**. If a product is defective it will be repaired in accordance with the terms of this warranty.

Warranty excludes consumable parts, for example: Filters, spark plugs and included accessories.

WARNING

The following actions will result in the warranty being void.

- Professional, Industrial or high frequency use.
- If the tool shows signs of damage or defects caused by or resulting from abuse, accidents or alterations.
- Failure to perform maintenance as set out within the instruction manual.
- If the tool is disassembled or tampered with in any way.

KNOW YOUR PRODUCT

PETROL TILLER

1. Throttle lock-off
2. Throttle lever
3. On/Off switch
4. Cross bar
5. Right handle
6. Left handle
7. Mid handle frame
8. Handle lock knobs
9. Lower handle frame
10. Recoil starter
11. Cable container
12. Choke
13. Spark plug
14. Connection plate
15. Drag stake
16. Fuel tank
17. Air filter
18. Primer bulb
19. Blade guard
20. Wheel
21. Bar shaft sleeve
22. Blade

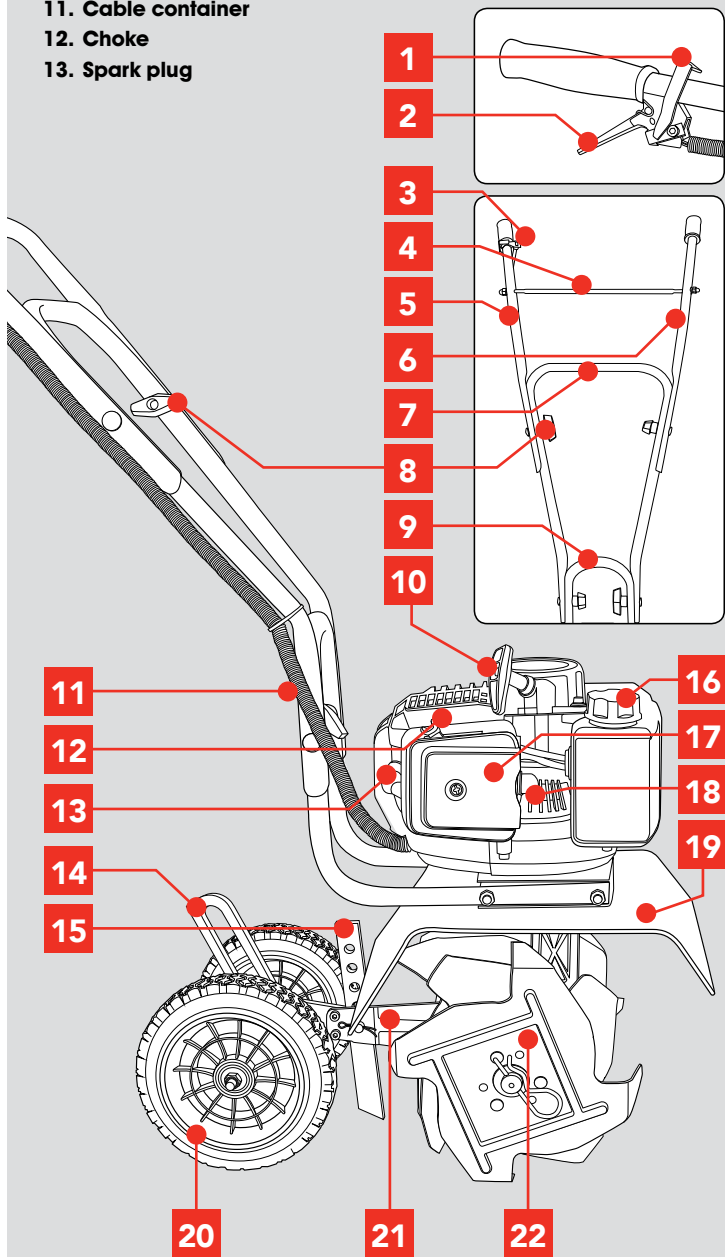

ONLINE MANUAL

Scan this QR Code with your mobile device to take you to the online manual.



ASSEMBLY

1. ASSEMBLING THE HANDLES

The handles and mid handle frame need to be secured in place before the unit can be used.

1. Place the mid-handle frame onto the lower handle frame so that it bends in the direction of the user.

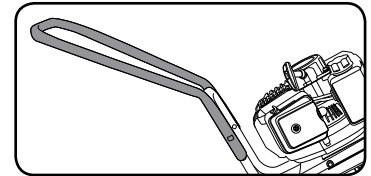

2. Ensure that the holes in the bars of both handle frames are in alignment. Using two of the handle lock knob and bolt sets, fix both handle frames together. The knobs should be positioned on the inside of the frame. Tighten them securely.

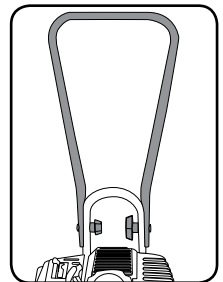

3. Attach the left and right handles to the mid handle frame with the remaining two handle lock knobs.

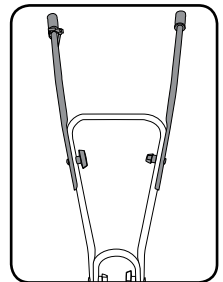

4. The cross bar acts as an additional support to the handle frame assembly. Insert each threaded end of the crossbar through the matching holes in the right and left handles. If fitting the cross bar is too difficult, loosen one of the upper handle lock knobs slightly.

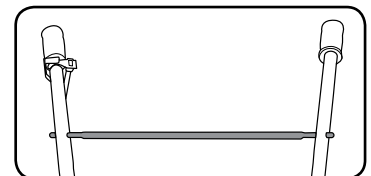

5. Cap the threaded ends of the cross bar with the spring washers and nuts supplied. Ensure all handle lock knobs are tightened securely.

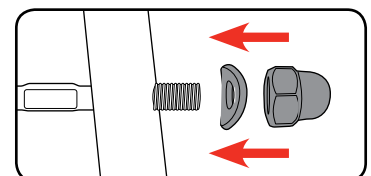

6. Use the cable clips (supplied) to fasten the cable container to the mid-handle frame and the right handle.

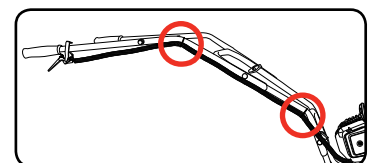

1 YEAR WARRANTY

SETUP & PREPARATION

2. ATTACHING THE WHEEL ASSEMBLY

1. Insert the front section of the connection plate into the rear opening of the bar shaft sleeve. Ensure that the holes in both sections are aligned.

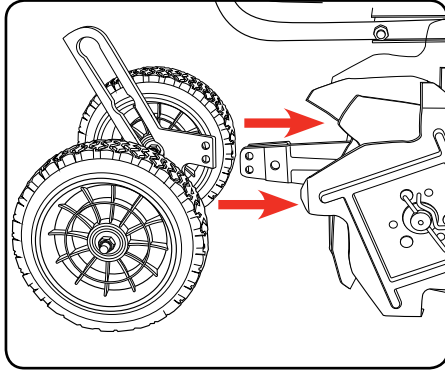

2. Insert the hex bolts through both holes and begin screwing in the nuts.

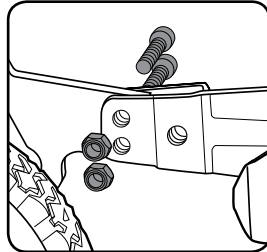

3. Using the 5mm hex key (supplied), keep the hex bolt in place while tightening the nut with the 10mm spanner (supplied).

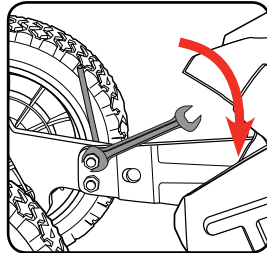

3. ADJUSTING THE TILLING DEPTH

The drag bar is used to regulate the depth of the turning tiller tines. It also serves as a brake, slowing the tiller's forward motion, enabling the blades to penetrate the soil.

WARNING! MAKE SURE THE ENGINE IS OFF AND THE SPARK PLUG DISENGAGED BEFORE INSTALLING THE DRAG BAR.

1. Slot the drag bar into the bar shaft sheath. The drag bar's pointed edge should face towards the tiller blades.

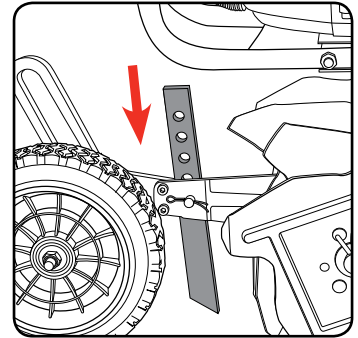

2. The drag bar has five holes that allow it to be set at five different heights. When you have selected the appropriate height, fix the drag bar in place with the split pin and lock pin (supplied).

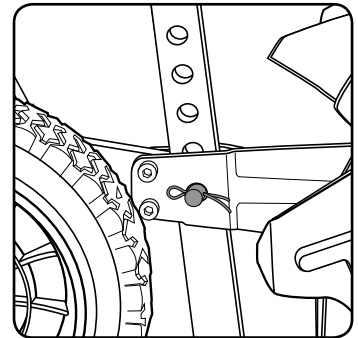

3. The ideal height of the drag bar will depend on the type of soil being tilled and soil conditions at the time of tilling. It can be set lower for deeper tilling and higher for shallower tilling. In general, however, the drag bar should be adjusted so that the tiller is tilted slightly backwards. The handles should come to a comfortable position around waist height for normal tilling.

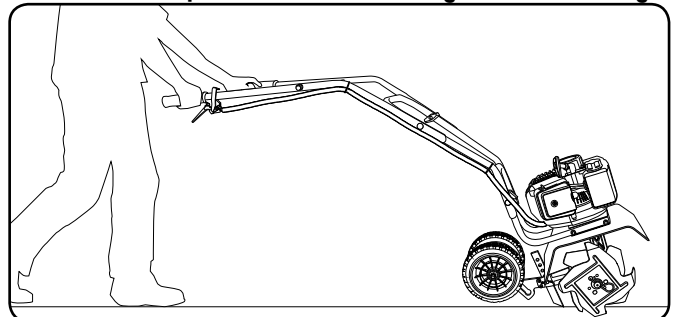

4. ADJUSTING THE WHEEL HEIGHT

1. The transport wheels can be adjusted into one of three grooves in the connection plate. When tilling, adjust the wheels so that they are set within the top groove.

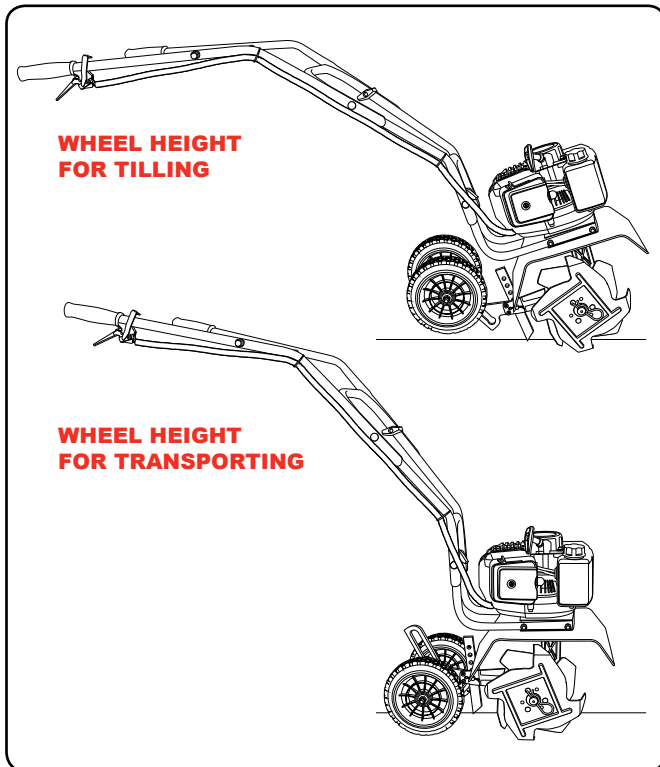

2. When not tilling, the transport wheels are used to move the machine around. They can be set within either the middle groove, or the lower groove. The setting will depend on the height of the user and whatever feels the most comfortable.

3. Adjusting the wheel height is achieved by gripping the axle collar, forcing it against the spring and away from the connection plate.

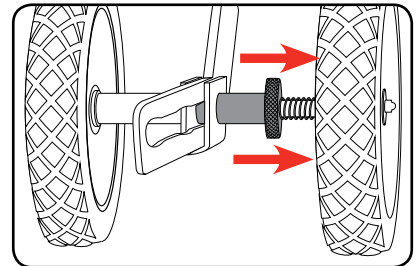

4. When the axle collar is disengaged from the groove in the connection plate, the wheel assembly is free to move. (This may be hard at first).

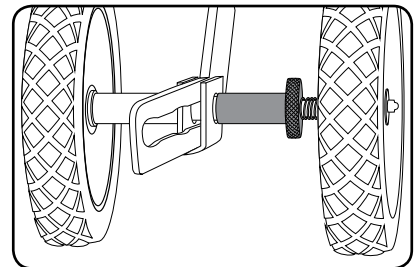

5. Shift the wheel assembly to the appropriate groove, depending on whether you are transporting or operating the tiller.

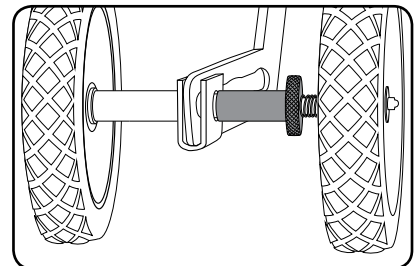

6. Release the axle collar so that it engages in the newly selected groove.

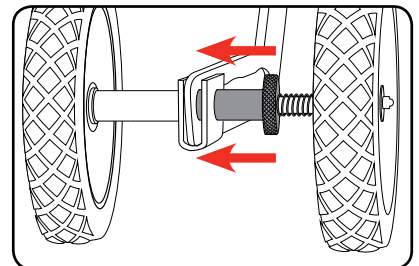

OPERATION

5. FUEL

WARNING! PETROL IS VERY FLAMMABLE. AVOID SMOKING OR CAUSING ANY SPARKS OR FLAMES NEAR FUEL. MAKE SURE THAT YOU STOP THE MOTOR AND ALLOW IT TO COOL BEFORE REFUELLING THE PETROL TILLER. SELECT AN OPEN OUTDOOR AREA FOR FUELLING AND MOVE AT LEAST 3M AWAY FROM THE FUELLING POINT BEFORE STARTING THE MOTOR.

Motor fuel: mix at 40:1 only

NOTE: Only use oil that is expressly labelled for use with air-cooled 2-stroke engines.

NOTE: Always transport and store fuels in an approved container (supplied bottle is for mixing only).

1. Fill with unleaded petrol (91 octane) up to fuel line.

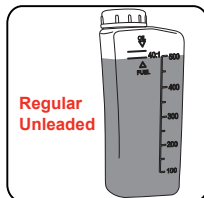

2. Add 2-stroke oil up to oil line. Shake vigorously for a thorough mix.

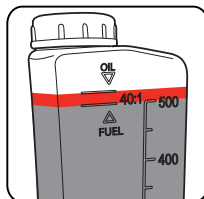

3. Fill the fuel tank to about 80% of its capacity with the fuel mix. Fuel tank capacity: 1000ml

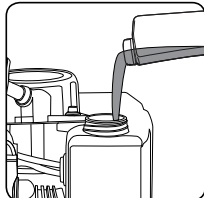

4. Fasten the fuel tank cap and clean any spillage.

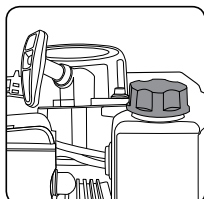

WARNING! NEVER ATTEMPT TO FUEL THE TILLER IF THE FUEL SYSTEM COMPONENTS ARE DAMAGED OR ARE LEAKING.

WARNING! ALLOW THE ENGINE TO COOL BEFORE FUELLING. NEVER ATTEMPT THE REFUEL THE ENGINE WHILE IT IS WARM OR STILL RUNNING.

WARNING! NEVER PLACE FLAMMABLE MATERIAL CLOSE TO THE ENGINE MUFFLER.

6. STARTING & STOPPING

Starting

NOTE: Do not squeeze the throttle before starting.

1. Press the ignition switch on the handle to the ON (I) position.

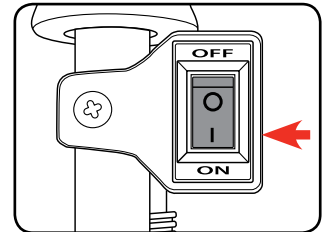

2. Press the primer bulb until full of fuel.

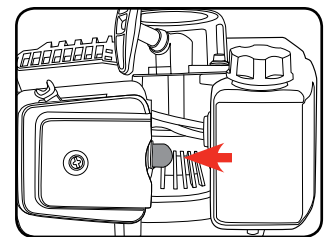

3. Push the choke lever to the start (OFF) position.

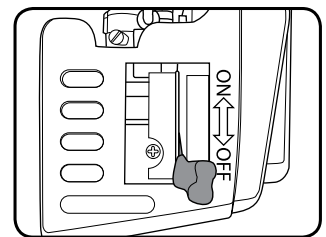

NOTE: Pressing the primer bulb and setting the choke to the start (OFF) position is unnecessary if the engine is warm.

Start position

4. Pull the recoil starter until the engine starts.

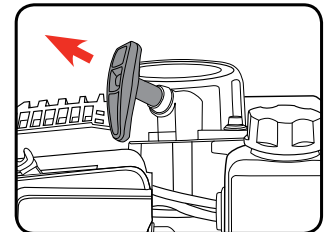

5. Push the choke lever half way and allow the motor to warm up (restart if the motor stops). After a few seconds move the choke lever to the run (ON) position.

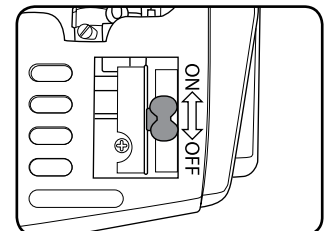

OPERATION

6. STARTING & STOPPING cont.

6. Tilt the tiller backwards, so that the blades are clear of the ground.

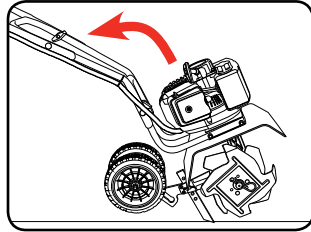

7. With your thumb, pull back the throttle lock-off and then squeeze the throttle lever. Allow the engine to run for 60 seconds so that it warms up.

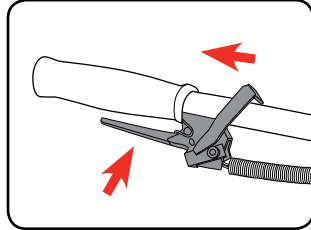

Stopping

1. When you wish to stop the engine, release the throttle so that the engine is idling and the blades stop spinning.

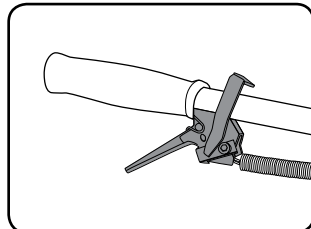

2. Press the ignition switch to the OFF (O) position, as indicated on the switch.

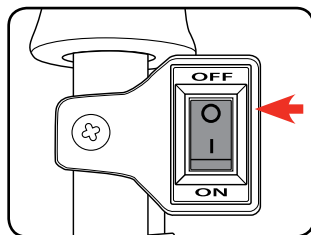

WARNING! THE TILLER RUNS FOR A FEW SECONDS AFTER IT HAS BEEN SWITCHED OFF. LET THE MOTOR COME TO A COMPLETE STANDSTILL BEFORE SETTING THE TOOL DOWN.

7. OPERATING THE TILLER

1. Start the engine, tilt the unit back on the depth stake until the blades are off the ground. Disengage the throttle lock-off and squeeze the throttle lever.

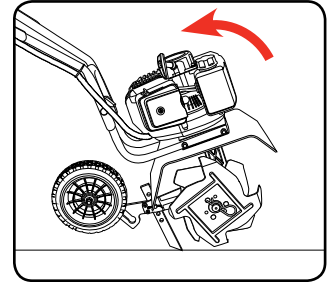

2. Firmly grip the handles and slowly tilt the unit forward to begin the tilling action.

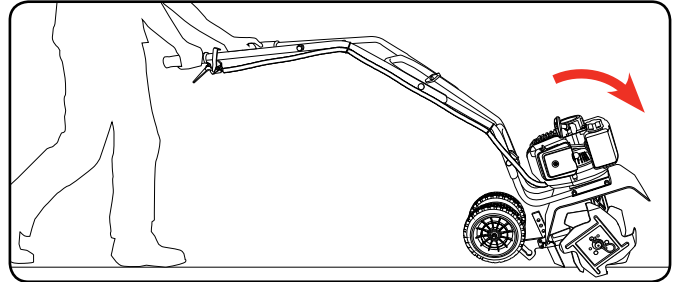

3. As the blades begin to make contact with the ground, hold the tiller in position until the blades dig into the soil.

Handling Tips

- By manipulating the handle bars, the user can control the depth and speed of the tiller. Pushing down on the handlebars will allow drag bar to penetrate the soil and slow the forward motion of the tiller.
- Easing up on the handlebars and moving the handlebars from side-to-side will release blades that are dug in too deeply.
- When turning, push down on the handlebars to bring the tiller's weight to the rear; this will make turning easier.

4. After an initial trial of the tiller, you may find that you need to readjust the depth stake. If you find that you have any of the following issues it will be beneficial to lower the depth stake:

- too little control over the tiller's forward motion
- the tiller moves forward too quickly
- the tilling depth is too shallow

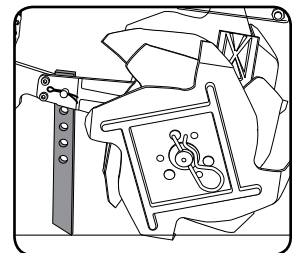

5. If you find that you have any of the following issues it will be beneficial to increase the height of the depth stake:

- the blades dig in, but the tiller

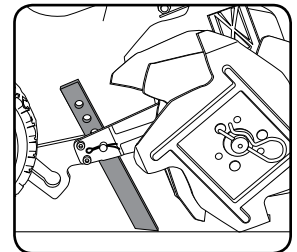

WARNING! KEEP HANDS, FEET AND CLOTHING AWAY FROM THE ROTATING BLADES. THEY CAN CAUSE INJURY.

CAUTION! WEAR PROTECTIVE FOOTWEAR WITH NON-SLIP SOLES, GLOVES, LONG SLEEVED SHIRT AND LONG PANTS MADE OF HEAVY MATERIAL. DO NOT WEAR LOOSE FITTING CLOTHES OR ITEMS WITH STRINGS OR STRAPS THAT COULD BECOME ENTWINED IN THE ROTATING TINES.

MAINTENANCE

8. GENERAL MAINTENANCE

- Keep the ventilation vents of the tool clean at all times, if possible, prevent foreign matter from entering the vents.
- After each use, blow air through the motor housing to ensure it is free from all dust particles which may build up. Build up of dust particles may cause the unit to overheat and fail.
- If the enclosure of the tool requires cleaning do not use solvents but a moist soft cloth or soft brush only. Never let any liquid get inside the tool; never immerse any part of the tool into a liquid.

Note: Ozito Industries will not be responsible for any damage or injuries caused by the repair of the tool by an unauthorised person or by mishandling of the tool.

Air filter

1. Use a screwdriver to remove the air filter cover screw and then remove the air filter cover.
2. Remove the air filter, brush off any dry particles, or dislodge them by tapping the air filter on a hard surface.
3. Replace the air filter, air filter cover and air filter cover screw.

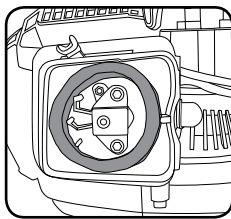
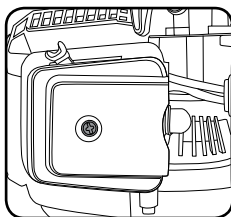

Replacing the spark plug

When the petrol tiller will not start and everything has been checked, it is possible that the spark plug will need replacing. The spark plug is not covered under warranty.

To replace the spark plug:

1. Pull the spark plug lead off the end of the spark plug.
2. Loosen (anti-clockwise) the spark plug using the larger socket side of the socket wrench provided.
3. Remove the spark plug and replace with a new one, as specified.

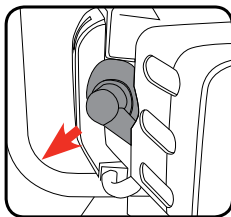

Spark plug: LD BM6A.

4. Secure the spark plug in position by tightening (clockwise) the spark plug using the socket wrench provided.
5. Fix the spark plug lead back to the end of the spark plug ensuring it clicks into place.

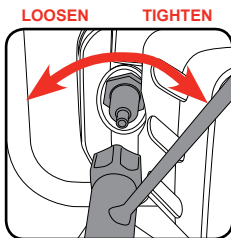

WARNING! BEFORE CLEANING YOUR PETROL TILLER OR CARRYING OUT ANY MAINTENANCE PROCEDURE, MAKE SURE THAT THE ENGINE IS OFF AND IS COOL. DISCONNECT THE SPARK PLUG TO PREVENT ACCIDENTAL STARTING.

DESCRIPTION OF SYMBOLS

cc	Cubic Centimeters (the standard measure of displacement in Europe and Asia)		
/min	Revolutions or reciprocation per minute	n _o	No load speed
	Use at a distance of at least 15m from other people.		Regulator compliance mark
	Diameter		Warning
	Read instructions		WARNING. Rotating blades.
	Wear safety glasses		Wear muffs
	Thrown objects can cause severe injury.		Flammable material.
	Contact with rotating tines will cause serious injury. Keep hands, feet, and clothing away while engine is running.		Extremely hot surface.
			Wear protective clothing
	Wear protective footwear		Wear gloves
	Do not expose fuel to open flame		Sound pressure level

SPARE PARTS

Blade Kit (Pair)	SPPTL4300-22K
Wheel	SPPTL4300-46
Knob Assembly (Pack of 4)	SPPTL4300-37A
Pin for Blade (Pack of 2)	SPPTL4300-70
Oil Cap Assembly	SPPTL4300-M69A

Spare parts can be ordered from the Special Orders Desk at your local Bunnings Warehouse.

For further information, or any parts not listed here, visit www.ozito.com.au or contact Ozito customer service Australia 1800 069 486 New Zealand 0508 069 486 E-mail: enquires@ozito.com.au

CARING FOR THE ENVIRONMENT



Tools that are no longer usable should not be disposed of with household waste but in an environmentally friendly way. Please recycle where facilities exist. Check with your local council authority for recycling advice.



Recycling packaging reduces the need for landfill and raw materials. Reuse of recycled material decreases pollution in the environment. Please recycle packaging where facilities exist. Check with your local council authority for recycling

SAFETY INSTRUCTIONS

RISK OF EXPLOSION OR FIRE

What can happen:

- Spilled petrol and its vapours can become ignited from cigarette sparks, electrical arcing, exhaust gases and hot engine components such as the muffler.
- Heat will expand fuel in the tank which could result in a fire.
- Operating the tool in an explosive environment could result in a fire.
- Muffler exhaust heat can damage painted surfaces, melt any materials sensitive to heat (such as siding plastic, rubber or vinyl) and damage live plants. Keep hot tool away from other objects.
- Improperly stored fuel could lead to accidental ignition. Fuel improperly secured could get into the hands of children or other unqualified persons.

How to prevent it:

- Shut off engine and allow it to cool before adding fuel to the tank.
- Use care when filling the tank to avoid spilling fuel. Move tool away from fuelling area before starting engine.
- Keep maximum fuel level 20mm below top of tank to allow for expansion.
- Operate and refuel in well ventilated areas free from obstructions.
- Store fuel in a approved container (AS/NZS 2906-1999) for petrol. Store in a secure location away from the work area. Make sure the container is clearly marked "fuel".

RISK TO BREATHING

What can happen:

- Breathing exhaust fumes can cause serious injury or death.

How to prevent it:

- Operate tool in a well ventilated area. Avoid enclosed areas.
- Never operate unit in a location occupied by other people or animals.

SAVE THESE INSTRUCTIONS

1) Work area

- a) Keep work area clean and well lit. Cluttered and dark areas invite accidents.
- b) Do not operate petrol tools in explosive atmospheres, such as in the presence of flammable liquids, gases, or dust. Power tools create sparks which may ignite the dust or fumes.
- c) Keep children and bystanders away while operating a petrol tool. Distractions can cause you to lose control.

2) Personal safety

- a) Stay alert, watch what you are doing and use common sense when operating a petrol tool. Do not use a power tool while you are tired or under the influence of drugs, alcohol, or medication. A moment of inattention while operating power tools may result in serious personal injury.
- b) Use safety equipment. Always wear eye protection. Safety equipment such as a dust mask, non-skid safety shoes, hard hat, or hearing protection used for

appropriate conditions will reduce personal injuries.

- c) Remove any adjusting key or wrench before turning the tool on. A wrench or a key that is left attached to a rotating part of the petrol tool may result in personal injury.
 - d) Do not overreach. Keep proper footing and balance at all times. This enables better control of the petrol tool in unexpected situations.
 - e) Dress properly. Do not wear loose clothing or jewellery. Keep your hair, clothing and gloves away from moving parts. Loose clothes, jewellery or long hair can be caught in moving parts.
 - f) If devices are provided for the connection of dust extraction and collection facilities ensure that these are connected and properly used. Use of these devices can reduce dust-related hazards.
- 3) Petrol tool use and care
- a) Do not force the petrol tool. Use the correct petrol tool for your application. The correct petrol tool will do the job better and safer at the rate for which it was designed.
 - b) Do not use the petrol tool if the switch does not turn it on and off. Any petrol tool that cannot be controlled with the switch is dangerous and must be repaired.
 - c) Turn tool off completely before making any adjustments, changing accessories, or storing petrol tools. Such preventive safety measures reduce the risk of starting the petrol tool accidentally. Hair can be caught in moving parts.
 - d) Store idle petrol tools out of the reach of children and do not allow persons unfamiliar with the petrol tool or these instructions to operate the petrol tool. Petrol tools are dangerous in the hands of untrained users.
 - e) Maintain petrol tools. Check for misalignment or binding of moving parts, breakage of parts and any other condition that may affect the petrol tool's operation. If damaged, have the petrol tool repaired before use. Many accidents are caused by poorly maintained petrol tools.
 - f) Keep cutting tools sharp and clean. Properly maintained cutting tools with sharp cutting edges are less likely to bind and are easier to control.
 - g) Use the petrol tool, accessories and tool bits etc., in accordance with these instructions and in the manner intended for the particular type of petrol tool, taking into account the working conditions and the work to be performed. Use of the petrol tool for operations different from intended could result in a hazardous situation.
 - h) This appliance is not intended for use by persons (including children) with reduced physical, sensory or mental capabilities, or lack of experience and knowledge, unless they have been given supervision or instruction concerning use of the appliance by a person responsible for their safety.
 - i) Children should be supervised to ensure that they do not play with the appliance.
- 4) Service
- a) Have your petrol tool serviced by a qualified repair personnel using only identical replacement parts. This will ensure that the safety of the petrol tool is maintained.

ADDITIONAL SAFETY INSTRUCTIONS FOR PETROL TILLERS

SAFETY RULES

CAUTION: ALWAYS DISCONNECT SPARK PLUG WIRE AND PLACE WIRE WHERE A IT CANNOT CONTACT SPARK PLUG TO PREVENT ACCIDENTAL STARTING WHEN SETTING-UP, TRANSPORTING, ADJUSTING OR MAKING REPAIRS BEFORE USE
Read the owner's manual carefully. Be thoroughly familiar with the controls and the proper use of the petrol tiller. Know how to stop the petrol tiller and disengage the controls quickly.

- Keep the area of operation clear of all persons, particularly small children and pets.
- Thoroughly inspect the area where the petrol tiller is to be used and remove all foreign objects. The tiller tines can throw rocks and other objects with enough force to cause injury.
- Avoid rotating tines. The rotating tines can cause injury. Keep away from the tine shield whenever the engine is running. If you need to adjust the tines or work around the tines for any reason, always stop the engine. Disconnect the spark plug cap if you need to clean or handle the tines.
- Keep shields in place. Guards and shields are designed to protect you from being hit by thrown objects. They also help protect you from hot engine parts and moving components. For your safety and the safety of others, keep all guards and shields in place when operating the tiller.
- Wear protective clothing. Wearing protective clothing will reduce your risk of injury. Long pants and eye protection reduce the risk of injuries from thrown objects. Sturdy shoes with aggressive soles will help protect your feet and give you better traction on slopes or uneven ground. Clothing worn by the operator should be close-fitting. Loose clothing should not be permitted because it may get caught in moving parts. Tie up or restrain long hair. Wear footwear that will improve footing on slippery surfaces.
- Turn engine off when not tilling. If you need to leave the tiller for any reason, even just to inspect the area ahead, always stop the engine.
- Do not make any modifications to your tiller. Modifying your tiller can make your tiller unsafe.
- Do not smoke while refuelling. This is potentially dangerous as it may ignite the fuel and cause an explosion.
- Take care not to spill fuel. When refuelling the tiller ensure that the motor has been switched off. Prevent the spilling of fuel as this may also ignite with the hot motor. Never refuel whilst the engine running.
- Be careful where you store the tiller. Store the tiller in a dry area away from flammable liquids.
- Ensure bystanders keep a safe distance. The tiller emits exhaust fumes.
- Ensure you use oil-mix fuel. Ensure that you mix 40 parts unleaded fuel to 1 part

engine grade oil. If not, the engine will overheat and cause damage to your tiller.

- Never fill fuel tank indoors. Never fill fuel tank when engine is running or hot. Do not smoke when filling fuel tank.
- Replace fuel tank cap securely and wipe up spilled fuel.
- Never remove the fuel tank cap or add fuel to a running or hot engine.
- Never store fuel or petrol tiller with fuel in the tank inside a building where fumes may reach an open flame.
- Never allow children or young teenagers to operate the petrol tiller. Keep them away while it is operating.
- Never allow adults to operate the petrol tiller without proper instruction.
- Always wear safety glasses or eye shields during operation or while performing an adjustment or repair to protect your eyes from foreign objects that may be thrown from the petrol tiller.
- Exercise extreme caution when operating on or crossing gravel drives, walks, or roads. Stay alert for hidden hazards or traffic.
- Exercise caution to avoid slipping or falling
- Never operate the petrol tiller at high transport speeds on slippery surfaces. Look behind and use care when backing.
- Never operate the petrol tiller without good visibility or light.
- Do not run the engine indoors. The exhaust fumes are dangerous (containing CARBON MONOXIDE, an ODOURLESS and DEADLY GAS).
- Take all possible precautions when leaving the petrol tiller unattended. Stop the engine.
- Do not overload the petrol tiller capacity by attempting to tilt too deep at too fast a rate.
- Keep the mini tiller/cultivator in safe working condition.
- Check all fasteners at frequent intervals for proper tightness.
- After striking a foreign object, stop the engine (motor). Remove the wire from the spark plug, and keep the wire away from the plug to prevent accidental starting. Thoroughly inspect the petrol tiller for any damage, and repair the damage before restarting and operating the petrol tiller.
- If the petrol tiller should start to vibrate abnormally, stop the engine (motor) and check immediately for the cause. Vibration is generally a warning of trouble. Stop the engine (motor) whenever you leave the operating position. Also, disconnect the spark plug wire before unclogging the tines and when making any repairs, adjustments, or inspections.
- When cleaning, repairing, or inspecting, shut off the engine and make certain all