

# SINK MIXER

## Installation Guide

---

### Technical Specifications:

#### Operating Pressure:

Min: 35kPa/0.35bar

Max: 500kPa/5bar\*

Optimum: 150kPa/1.5bar - 500kPa/5bar

#### Operating Temperature:

Hot: Max 80°C\*

Cold: Min 5°C

#### Inlet Connections:

All ½" BSP

*\* Regional specific regulations apply.  
Please refer to your warranty statement  
at [www.methven.com](http://www.methven.com)*

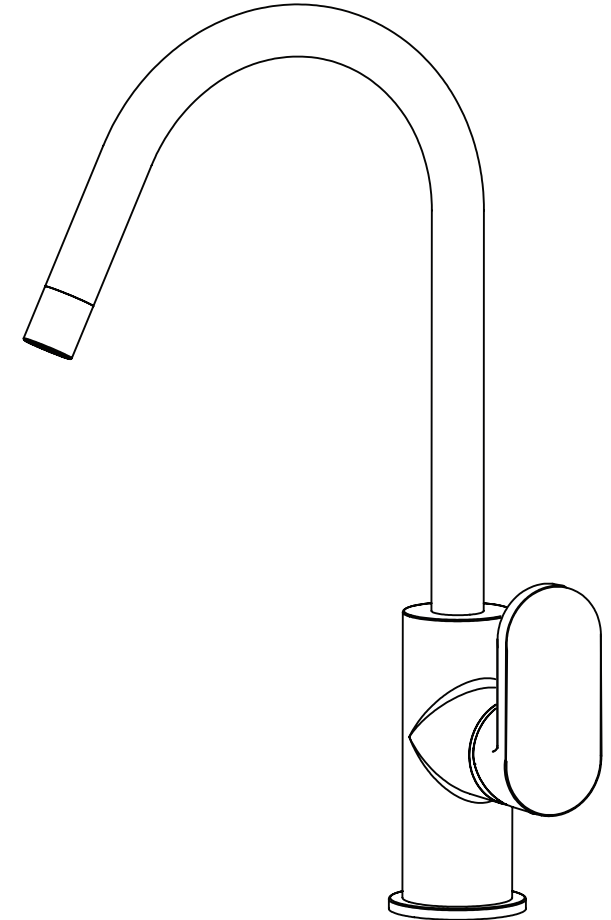

Methven warrants this product against manufacturing defects and that it is suitable for use under the general operating conditions specified in this instruction sheet. However, regional regulations apply and may affect your warranty. Please refer to [www.methven.com](http://www.methven.com) or call customer service for full details.

New Zealand  
0800 804 222

Australia  
1300 638 483

UK  
0800 195 1602

432112

ISSUE A

**FLEXISPRAY**  
By METHVEN

**IMPORTANT:** Please read all of the instructions before installation.

### General:

- Methven recommends this product is installed by a licensed plumber in compliance with all relevant regional regulations.
- Do not hydrostatic test the installation with this mixer installed. Damage to the ceramic cartridge may occur.
- All pipe work must be thoroughly flushed prior to the installation of the mixer.
- In-line filters must be fitted on both hot and cold supplies to prevent foreign particles damaging the ceramic cartridge.
- Do not remove the ceramic cartridge from the mixer when installing.
- After installation all connections must be checked for leaks.
- All outlets used primarily for personal hygiene shall deliver water at a safe temperature as per regional regulations.
- This mixer is not recommended for use in uncontrolled heating systems such as wet-backs or solar heating units unless a suitable tempering valve is fitted.
- If limited water flow is experienced, locate aerator and filter washers and clean away foreign material as required.
- It is the responsibility of the installer to ensure a waterproof seal is achieved between the product and mounting surface. If in doubt about the quality of the seal, remove the product and reinstall using silicone to ensure a seal is achieved.

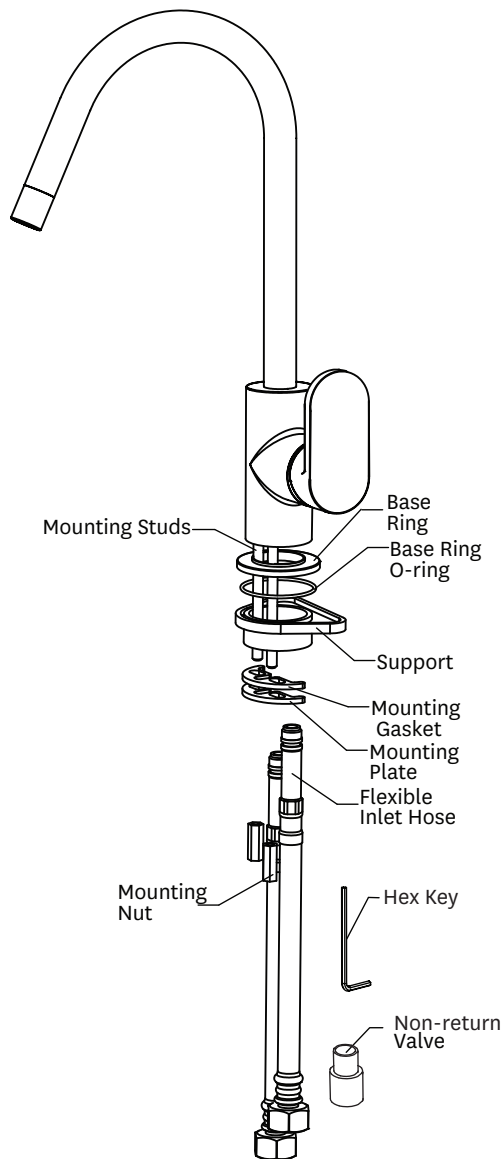

### Care and Cleaning:

- Never use abrasives or abrasive cleaning agents to clean this product. Clean regularly with contamination free warm soapy water and a damp soft cloth.

**IMPORTANT:** Before you begin, turn-off the water supply. It is recommended to fit isolation valves to both the hot and cold supply.

### Installation:

1. Cut a single 35mm diameter hole into the mounting surface or use existing hole.
2. Insert o-ring provided into the groove in the bottom of the base ring.
3. Unscrew mounting nuts and remove mounting plate, mounting gasket and one flexible inlet hose if necessary.
4. Place base ring over hole ensuring that the o-ring remains in place.
5. Feed hose and mounting studs through the base ring and hole in the mounting surface.
6. Screw second hose into base of mixer if removed in step 3.
7. Fit triangular mixer support if required, e.g. stainless sinks.
8. Slide mounting gasket and mounting plate onto mounting studs.
9. Position the mixer as desired.
10. Tighten mixer body to the mounting surface using the mounting nuts supplied.

**Please Note:**

Make sure the o-ring in the base ring seals completely around the hole in the mounting surface.

**Unequal pressure installation only:**

Attach non-return valve to the hot inlet hose.

12. Connect the 1/2" BSP Female hose fittings to the hot and cold supplies. Turn on the water supply and check carefully for leaks. Retighten joints if necessary.

**Low and Unequal pressure installation only:**

Unscrew aerator. Replace with Flow Straightener.

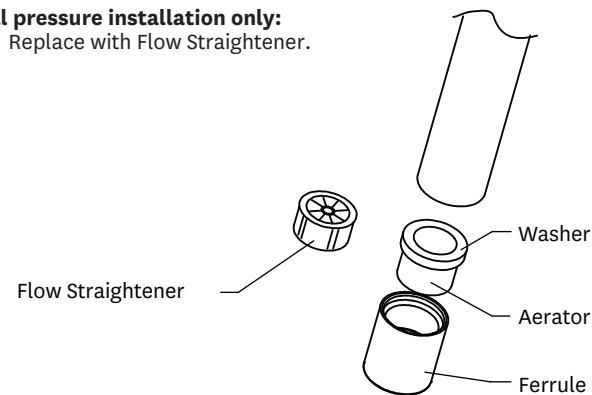

**Do not stretch or twist hose**

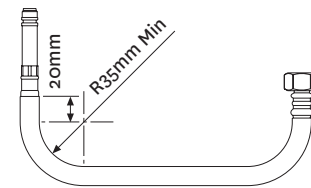
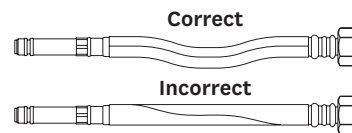

**DO NOT crush Hose or swaged Ends**