

**Elephant Plasterboard  
Installation Guide**  
August 2015



**Elephant**  
INSTALLATION  
**GUIDE**

[www.elephantplasterboard.co.nz](http://www.elephantplasterboard.co.nz)



**Elephant**  
**Plasterboard**

STRENGTH WITH STYLE



## Elephant Plasterboard Installation Guide Publications

---

These publications are continuously being updated and superseded. It is important to check to ensure you have the latest publication. Call Free Helpline 0800 ELEPHANT (353742).

### Elephant Plasterboard Installation Guide

Liability for systems that are not designed and installed in accordance with this publication will not be accepted by Elephant Plasterboard (NZ) Limited.

### Copyright

All the material in this document including text, diagrams, figures, patterns, drawings and tables are protected by Copyright. This includes the Elephant Quickbrace Numbering System and the sub-components thereof.

### Elephant Plasterboard (NZ) Limited Trademarks:

Elephant Plasterboard, Elephant Gypsum Board,  
Elephant Board, Elephant Standard Plasterboard,  
Elephant Superboard, Elephant Multiboard,  
Elephant Fireboard, Elephant Braceboard,  
Elephant Aquaboard, Elephant Smartboard,  
Elephant Standard-Plus, Elephant Noiseboard,  
Elephant Impactboard, Elephant Ultraboard

### Free Helpline

0800 ELEPHANT (353-742).

### Email

[info@elephantpb.co.nz](mailto:info@elephantpb.co.nz)

### Website

[www.elephantplasterboard.co.nz](http://www.elephantplasterboard.co.nz)

### Telephone

(09) 818-7706

### Facsimile

(09) 818-7702

Elephant Plasterboard (NZ) Limited  
P.O. Box 21-436, Waitakere 0650  
New Zealand



# Contents

<b>INTRODUCTION</b>	4
Elephant Plasterboard Product & System Warrantee	4
Product Description	4
Building Code Compliance	4
Conditions of Use	5
Maintenance	5
Substitution	5
Levels of Finish	6
Product Range	7
<b>PRE-INSTALLATION</b>	8
Pre-Inspection of the Site Framework	8
Framing Spacings	8
Planning and Measuring	8
Delivery, Handling and Storage	9
Timber Frame Moisture Content	9
<b>GENERAL WALL AND CEILING INSTALLATION</b>	10
Inspection of Framing	10
Cutting Elephant Plasterboard	10
Fixing Methods – General	11
Fixing to Ceilings	12
Fixing to Timber Frame Walls – Horizontal Method	13
Fixing to Timber Frame Walls – Vertical Method	14
Fixing to Steel Frame Walls – Horizontal Method	15
Fixing to Steel Frame Walls – Vertical Method	16
Back-blocking	17
Curving Elephant Plasterboard	18
Concrete and Masonry Walls – General	19
Direct Bonding	19
Fixing to Furring Channel	20
<b>ELEPHANT PLASTERBOARD BRACING SYSTEMS</b>	22
QuickBrace™ Numbering System & Performance Table	22
Wall and Ceiling Construction Details – Framing	23
Top Plate Connections	23
Panel End Hold Down Details	24
Intersecting Walls	26
Parapet’s Gabled End Walls or Dropped or Suspended Ceilings	26
Ceiling Diaphragms Construction Details	27
Fastening the Plasterboard Linings to Walls	29
Wet Areas	30
Openings in Bracing Elements	30
Bracing Systems: Plasterboard on One Side	31
Bracing Systems: Plasterboard on Both Sides	32
Bracing Systems: Plasterboard on One Side Plywood the Other	33
<b>JOINTING AND FINISHING</b>	35
External and Internal Corners	35
Control Joints	37
Decoration	38
<b>REPAIRS AND MAINTENANCE</b>	39
Accidental Damage	39



## INTRODUCTION

---

This publication contains within it, the recommended methods for fixing 10mm Elephant Standard-Plus and 13mm Elephant Standard-Plus Plasterboard. Elephant Plasterboard systems designed for fire rating, bracing, wet area, and acoustical control may not be fully covered by this publication. It is important that reference is made to separate publications for fire, wet area, sound control and bracing systems in regard to fixing and jointing recommendations.

### Elephant Plasterboard Product & System Warrantee

Elephant Plasterboard wall and ceiling linings are supported by Elephant Plasterboard's Quality Guarantee. This Warrantee covers Elephant Plasterboard products and or systems for a minimum of 10 years from the date of the purchase. Elephant Plasterboard supplies products which are warranted to be free from defects. Any products found to be defective before or after installation will be replaced and/or repaired, provided installation has been in accordance with Elephant Plasterboard's technical literature.

### Product Description

Elephant Plasterboard is a strong, dense sheet lining for walls and ceilings and has been specifically manufactured and tested for New Zealand and Australian conditions. It complies with AS/NZS 2588. It can be easily installed by the tradesman or home handyman.

The dense pure gypsum core is encased in a high quality face paper and backing paper, produced using a continuous production procedure. This remarkable material is renowned for its stability, acoustic control, bracing and fire resistance.

Along the longitudinal edges sheets are tapered edged so as to allow reinforcing tapes and plaster in the joints. This is designed to produce a stable crack resistant surface. Square, tapered sheets are also available for horizontal applications.

### Building Code Compliance

Elephant Plasterboard is manufactured to the International Standard ISO 9001, and has been specifically designed to meet New Zealand and Australian Standards and Building Code requirements.

Elephant Plasterboard has been marketed internationally since 1975 and the product has established an excellent history of performance for its use in buildings throughout New Zealand and Australia.

Elephant Plasterboard meets the durability requirements of the NZBC and BCA and is subject to use, installation and maintenance in accordance with the Manufacturer's instructions.

The NZBC durability requirement under Clause B2.3 c) and d) for general linings is between 5 and 15 years depending on the ease of access and replacement.

Elephant Plasterboard systems, used as a general lining, including adhesive fixing when using an adhesive recommended by the manufacturer for this application, satisfy the 15 year durability requirements of the NZBC.

Elephant Plasterboard systems fixed mechanically using only screws or nails achieve a 50 year durability performance.

### Related Documents

#### New Zealand Building Code

#### Approved Documents:

Clause B1	Structure	Clause E2	External Moisture
Clause B2	Durability	Clause E3	Internal Moisture
Clause C1	Outbreak of Fire		



## INTRODUCTION

---

### Conditions of Use

Elephant Plasterboard systems are intended for normal conditions of dry internal use. All performance testing of Elephant Plasterboard systems has been carried out using dry ex-factory product. Elephant Plasterboard Drywall systems must not be exposed to liquid water or be installed in situations where extended exposures to humidities above 95% Relative Humidity are to be expected.

A suitable surface finish must be applied to Elephant Plasterboard in all areas where liquid water or high humidity can be expected. Vinyl wallpaper and gloss and semi-gloss alkyd paints are suitable systems. Bathrooms, kitchens and laundries for example should have adequate ventilation or heating to avoid condensation buildup.

### Maintenance of Elephant Plasterboard Drywall Systems

The long term durability of an Elephant Plasterboard system is conditional upon, the systems being kept dry in service, compliance with the New Zealand Building Code clauses E2 External Moisture and E3 Internal Moisture. This compliance ensures dry internal conditions and alleviates the circumstances which may lead to timber movement, corrosion of metal components, moisture uptake by the gypsum core and fungal growth.

Elephant Plasterboard is a finishing material and must be fully protected during construction from direct sunlight, moisture and direct impact.

NZBC Clause C1 Outbreak of Fire provides for a performance under C1.3.2 that a fixed appliance shall not raise the temperature of an element to a level that would adversely affect its physical properties. The maximum service temperature for Elephant Plasterboard is 50°C; above which the gypsum core undergoes chemical conversion.

The paper face of the Elephant Plasterboard should be kept intact and care exercised during wet stripping of wallpaper, afterwards the surface made good wherever necessary prior to redecoration. The making good of the paper face is important because plasterboard is a composite laminate and the gypsum core and paper face each contribute to the lining's performance. The making good would include using paper jointing tape and jointing compounds over scratches or cuts in the paper face.

Any surface damage to the paper face or corners caused by normal 'wear and tear', should be made good as soon as practicable otherwise ongoing wear and tear, if it remains unchecked, may lead to the integrity of the board being compromised. If cracks occur at the joints or nail pops occur in the surface of the board, the reason for the problem should be investigated and rectified. The cracks and nail pops should be made good as soon as practicable thereafter. Control joints should be provided to relieve stresses imposed by movement due to moisture, temperature or structural changes. Details of joint design should be obtained from the designer where control joints have been specified to be carried through Elephant Plasterboard linings.

If cracks occur at junctions of bracing elements or at joints in fire or acoustic systems they must be made good immediately. The penetration of fire and sound control systems by unprotected services is detrimental to their performance and must be avoided.

### Substitution

If Elephant Plasterboard have been selected at design stage, it is important to note that these systems may not be substitutable by other plasterboard systems. All components, framing design, fixing layout and fasteners details must be strictly adhered to in order to ensure the performance of the systems originally specified.



## INTRODUCTION

---

### Levels of Finish

Different applications for Elephant Plasterboard may require different specifications according to where it is to be used and the level of finish required. The following gives details of how to choose a level of finish for Elephant Plasterboard installations depending upon the final decoration of the room.

#### Level 3

For use in areas which are to receive heavy or medium texture (spray or hand applied) finishes before final painting, or where heavy grade wall coverings are to be applied as the final decoration. This level of finish is not generally suitable where smooth painted surfaces or light to medium weight wall coverings are specified.

##### > Description

Typically all joints and interior angles would have tape embedded in joint compound and one separate coat of joint compound applied over all joints and fastener heads. All joint compound should be finished smooth. (Generally this is achieved by scraping off ribs and ridges and the like with the edge of a trowel).

#### Level 4

For use where light textures or wall coverings are to be applied. It is also for non-critical lighting areas where flat and low sheen paints are to be applied. In critical lighting areas, flat paints applied over light textures tend to reduce joint photographing. Gloss and semi-gloss paints are not generally suitable over this level of finish.

The weight, texture and sheen level of wall coverings applied over this level of finish should be carefully evaluated. Joints and fasteners must be adequately concealed if the wall covering material is lightweight, contains limited pattern, has a gloss finish, or has any combination of these features.

##### > Description

Typically all joints and interior angles would have tape embedded in joint compound and a minimum of two separate coats of joint compound applied over all joints, angles, fastener heads and accessories. All joint compound should be finished smooth and free of tool marks and ridges.

#### Level 5

This level of finish is for use where gloss or semi-gloss paints are specified or where critical lighting conditions occur.

##### > Description

Typically all joints and interior angles would have tape embedded in joint compound and a minimum of two separate coats of joint compound applied over all joints, angles, fastener heads and accessories. All joint compound should be finished smooth and free of tool marks and ridges. This should be followed by proprietary surface preparations or (in some areas) skim coating to remove differential surface textures and porosity. Local advice should be sought prior to finish for gloss paints or in areas of critical lighting.

### Skim Coating

Skim coating is a term denoting a thin finish coat, trowelled or airless sprayed to achieve a smooth finish. It is a thin coat of joint compound over the entire surface to fill imperfections in the joint work, smooth the paper texture and provide a uniform surface for decorating. Skim coatings would not normally exceed 1mm in finished thickness.

For further details on the factors affecting levels of finish, reference should be made to the following:

#### “Plasterboard Expectations”

Published by Gypsum Lining Council of Australia and New Zealand available through the Federation of Wall and Ceiling Industries of Australia and New Zealand.

**Illumination and Decoration of Flat Surfaces:** CSIRO Division of Building Research as Report No. L8, 1960.

**Australia/New Zealand Standard:** Gypsum Lining – Application and Finishing AS/NZS 2589:2007.



# INTRODUCTION

## Product Range

TE/TE = Tapered Both Edges

TE/SE = Tapered One Edge, Square the Other

## Product Weights and available Lengths

PRODUCT	THICKNESS mm	EDGE TYPE	WIDTH mm	WEIGHT Kg per m <sup>2</sup>	LENGTH								
					2.4m	2.7m	3.0m	3.3m	3.6m	4.2m	4.8m	6.0m	
Standard-Plus	10	TE/TE	1200	7.4									
Standard-Plus	13	TE/TE	1200	9.2									
Horizontal Standard-Plus	10	TE/SE	1200	7.4									
Horizontal Standard-Plus	10	TE/SE	1350	7.4									
Multiboard	10	TE/TE	1200	9.0									
Multiboard	13	TE/TE	1200	12.0									
Multiboard	16	TE/TE	1200	13.8									
Aquaboard	10	TE/TE	1200	8.5									
Aquaboard	13	TE/TE	1200	11.5									

## Product Primary Functions

PRODUCT	THICKNESS mm	EDGE TYPE	WIDTH mm	PRIMARY FUNCTIONS								
				Superior Finish	Horizontal Fixing	Span 600° Centres on Ceilings	Bracing	Fire Resistant	Noise Control	Impact Resistant	Water Resistant	
Standard-Plus	10	TE/TE	1200	•		•	•	•				
Standard-Plus	13	TE/TE	1200	•		•	•	•				
Horizontal Standard-Plus	10	TE/SE	1200	•	•		•	•				
Horizontal Standard-Plus	10	TE/SE	1350	•	•		•	•				
Multiboard	10	TE/TE	1200	•		•	•	•	•			
Multiboard	13	TE/TE	1200	•		•	•	•	•	•		
Multiboard	16	TE/TE	1200	•		•	•	•	•	•		
Aquaboard	10	TE/TE	1200	•		•	•	•	•		•	
Aquaboard	13	TE/TE	1200	•		•	•	•	•	•	•	•

\* In areas with significant temperature or humidity variations e.g. bathrooms, it is recommended to place battens at max 450mm centres when using 10mm Standard-Plus or 10mm Aquaboard



## PRE-INSTALLATION

### Pre-Inspection of the Site Framework

- Check that the framing is plumb, level and square and has been erected according to the relevant building specification. The framing must have a minimum flat face width of 35mm for timber and 32mm for steel.
- Plumbing and electrical services should be installed before the plasterboard is fixed and all service ducting, pipes, outlets and switch boxes should be set back from the framing and not protrude beyond the face of the framing.
- Make sure all contact surfaces of the framing are dry and free from dirt, grease, oil or any other foreign material.
- Where level 3, 4 or 5 finishes are specified (see heading **Levels of Finish** on page 6) the deviation in the position of the bearing surface of the framing from a 1.8m straight edge shall not exceed 2mm when measured over a 1.8m span at any point along individual members or across adjacent members.

Note – The fixing of Elephant Plasterboard is deemed to be an acceptance of the substrate, so it is important to make sure that the above requirements are adhered to.

### Framing Spacings

The spacing of framing support for Elephant Plasterboard linings shall not be greater than 600mm centres for all thicknesses of Elephant Plasterboard.

The requirements for wall and ceiling framing spacings are detailed below.

- It is recommended that Framing centres be kept at 450mm in Bathrooms or other areas that may be subject to moisture and steam when using 10mm Standard-Plus or 10mm Aquaboard.

On ceilings we recommend the use of steel battens, as timber battens can be subject to expansion and contraction.

Location	Framing Centres	Thickness and Type
Wall	600mm	10mm Standard-Plus or greater
Ceiling	600mm*	10mm Standard-Plus or greater

### Planning and Measuring

- Good planning of sheet layout is important. This will reduce wastage and keep the number of joints to a minimum, saving time and extra costs.
- On ceilings the use of maximum sheet sizes minimises the occurrence of end butt joints. Where end butt joints occur they must be formed, preferably, between framing members where joints can be neatly finished using the “back-blocking” method (see pages 17,18).
- Sheets may be fixed either vertically or horizontally and should ideally run right through and over doors and windows. The window and door openings are then able to be cut out when sheets are in place.
- Joints should not occur within 200mm of door or window frame corners or on jamb studs as this is a point of stress.

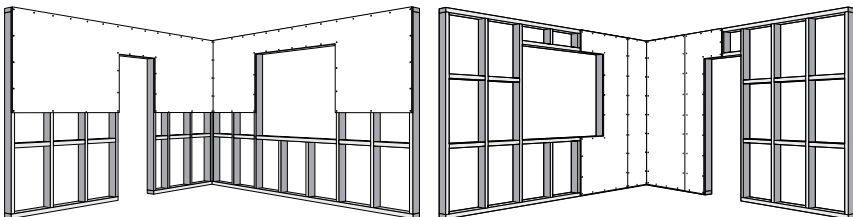





## PRE-INSTALLATION

---

### Delivery, Handling & Storage

- Where possible Elephant Plasterboard should be delivered to site immediately before installation as this greatly reduces the possibility of damage.
- Sheets should be neatly stacked to avoid sheet distortion, damage or moisture ingress. This can be achieved by stacking on a clean flat surface that is not susceptible to moisture. Use a moisture barrier (e.g. polythene sheet) when standing sheets on concrete floors.
- Alternatively sheets can be stacked on supports parallel to the ends of the linings and extending full width of the sheet at no more than 600mm centres.
- Care should be taken to prevent undue sagging or damage to edges, ends or surfaces during storage and handling.
- All materials should be kept dry, preferably by being indoors and under cover (especially when storage is likely to be for a lengthy period). While stored plasterboard should be protected from moisture and direct sunlight.
- Elephant Plasterboard should not be used where it will be exposed to excessive moisture.
- The front face of the sheets should be kept face down to prevent footprints and other marks or damage to the face.
- Cracked or damaged sheets must not be used.
- Floor Loadings should be considered as the Elephant Plasterboard can weigh in the range of 700–900 kg/m<sup>3</sup>.
- When floor space is limited, sheets may be leaned against a wall 150–180mm from the bottom plate.  
Maximum number of sheets when stacked against a wall;  
10mm or 13mm – 18  
16mm – 12.

### Timber Frame Moisture Content

When Elephant Plasterboard is fixed to timber containing excessive moisture, problems may occur which can affect the finished appearance of the wall or ceiling. These can occur in the form of –

- The appearance of mould as the moisture migrates through the plasterboard.
- Nails or screws popping from timber shrinkage.
- Joints cracking when frame expands.
- Joints peaking when the frame shrinks as it dries.

To achieve a level 3, 4 or 5 finish, timber must have a moisture content of between 12–18% (inclusive) at the time of lining. This is required of the substrate for the direct fixing of Elephant Plasterboard. Overly dry timber at time of lining (especially in Summer months) can result in cracking of joints because when moisture is re-absorbed in wetter seasons timber framing begins to expand.

Consider back-blocking on the tapered joints of horizontal fixed sheets, especially on wall heights over 2.7 metres.

- Install Plasterboard when the timber moisture content is within 2% of the final expected ambient moisture content.
- It is recommended to use steel battens on ceilings.
- If timber battens are unavoidable it is also recommended that the moisture content of the timber battens should not exceed 16% at the time of lining.

For more information see BRANZ Information Bulletin No. 301 Avoiding Peaking and Popping with Gypsum Plasterboard. Nov. 1992. Plasterboard Expectations.



## GENERAL WALL AND CEILING INSTALLATION

The following section covers the installation of Elephant Plasterboard in general wall and ceiling applications. This is followed by a guidance on the installation of Elephant Plasterboard Bracing Systems. For information regarding Acoustic and Fire Systems installation refer to the appropriate literature.

### Inspection of the Framing

- Flatness of Framing  
Inspect the surface of the framing and ensure that it is flat. In particular take note of nails not seated below the surface, nogs not flush, hold down straps not checked in flush to the surface etc.
- Moisture Content of the Framing  
Reliance should not be made on the building inspector alone at pre-line stage. It is important to ensure the framing is dry and to understand the effects of framing moisture on the overall finish of the wall and ceiling linings.
- Insulation Material  
Ensure that insulation material is not bulging out of the framing. Otherwise this will apply pressure on the lining material and may cause screw or nail popping.

These issues must be corrected prior to the fixing of the lining materials to the framing. Once fixing starts, this indicates that there has been an acceptance of the substrate quality. Therefore it is the responsibility of the framing contractor to ensure that the substrate will allow the fixer to fix in accordance with manufacturers instructions and recommendations.

Furthermore it is important for the fixer to provide a suitable surface, for the plasterboard stopper to conduct the stopping process in an effective way.

### Cutting Elephant Plasterboard

- Elephant Plasterboard is easily cut by scoring or sawing with all work done on the face of the board.
- When scoring use a sharp drywall knife and straight edge. When cut the board may be snapped away from the cut face and the back paper can then be cut.
- Cut-outs for switch boxes and other penetrations should be scored on both surfaces before trying to remove waste board. Care should be taken to avoid damaging the core during this procedure.

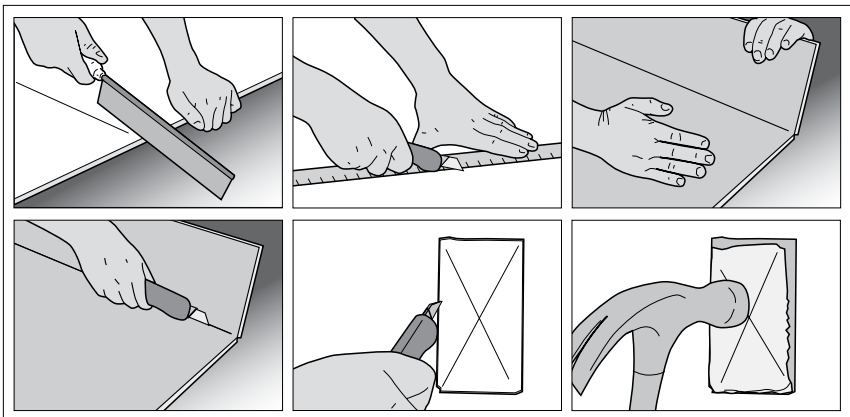



## GENERAL WALL AND CEILING INSTALLATION

### Fixing Methods

#### General

- Elephant Plasterboard must be fixed leaving a gap of approximately 10mm at the floor level to allow for movement of framing members.
- All nails and screws should be driven in to the plasterboard at right angles and to a depth so that heads are seated in a slight recess.
- A lightweight hammer (16oz or less) or a drywall hammer must be used to avoid breaking the paper face surface of plasterboard by overdriving the fixings.
- Daubs of wallboard adhesive should be about 30mm in diameter.
- Never place the mechanical fixings through wallboard adhesive.
- Always keep the mechanical fixings 12mm from the sheet edge.
- For bracing elements fixing refer pages 28–30.

#### Walls

There are two approved methods for fixing plasterboard to framing members –

**Horizontal Fixing** – Board fixed at right angles to the studs.

**Vertical Fixing** – Board fixed parallel to the studs.

By fixing sheets using the horizontal method the number of joints is considerably reduced giving a generally higher quality wall finish. Plasterboard also has greater strength along its length so will offer more support between spans when fixed this way. Where the face of the framing member is reduced, horizontal fixing is also preferred as it is more difficult to fix two sheets on the smaller surface.

- When fixing over doors and windows it is recommended that joints do not occur on load bearing door and window studs. Sheets should be fixed horizontally and waste plasterboard cut out after it has been fixed.
- Joints should not occur within 200mm of door or window frame corners or on jamb studs as this is a point of stress.

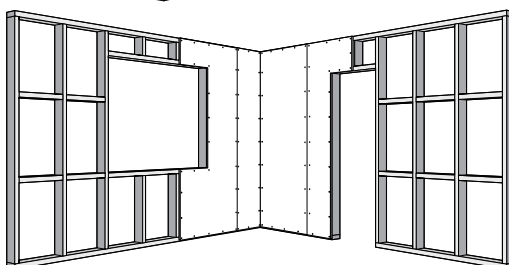
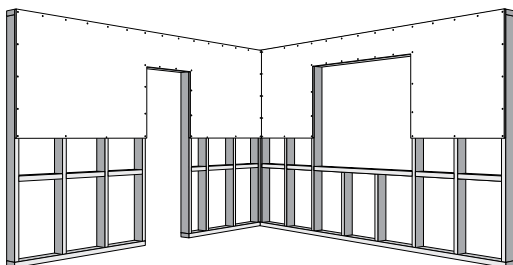



## GENERAL WALL AND CEILING INSTALLATION

### Fixing to Ceilings

#### Adhesive/Screw

- Fix ceiling sheets across battens or joists.
- Steel battens are recommended.
- Refer to table on page 8 for suitable board thickness and framing centres.
- Apply adhesive to battens or joists at 200mm centres between centre and edge of sheet.
- Start fixing from the centre of each sheet outwards.
- Position the sheet hard up to the framing, single screw at the centre line and the edges across each batten.
- Nailing is not recommended.
- Single screws to be minimum 12mm from sheet edge.
- Press the plasterboard where adhesive has been applied to ensure full contact.
- Sheet end joints must not be made on framing and must be back-blocked.
- Back-blocking of sheet ends and recessed joints is essential for a high quality finish. (See table on page 17).
- Fix the edges of the sheet at the wall junction at 200mm centres.
- Adhesive must not be applied to the sheet edges or under screws. This may contribute to screw popping.
- All joints between sheets should be touch fitted.
- Use long length sheets to minimise sheet end butt joints.
- The use of a drywall lifter will greatly assist the builder in achieving optimum results.

#### Fasteners

Steel Battens	25mm x 6 gauge self tapping drywall screws
Timber	32mm x 6 gauge coarse thread drywall screws

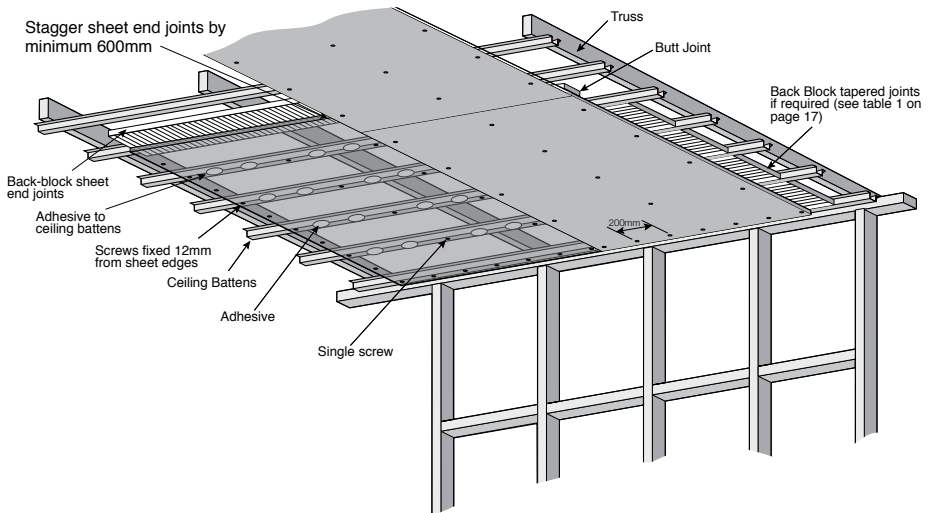



## GENERAL WALL AND CEILING INSTALLATION

### Fixing to Walls – Timber Frame Horizontal Method

#### Wall Framing

Dimensions for framing must comply with NZS3604:2011 requirements.

- Timber Framing moisture content should be between 12–18% when lining is installed.
- Studs must be spaced at 600mm centres maximum when using either 10mm or 13mm Elephant Plasterboard.
- For wall heights up to 2700mm use either
  - (a) 2 rows of nogs spaced evenly or
  - (b) 1 row of nogs staggered to a max 150mm from either side of centre line.
- Where the stud height is between 2400–2700mm, Elephant Plasterboard has 1350mm wide sheets to install horizontally.
- An additional row of nogs is required for wall heights up to 3600mm.
- Sheet end joints made on framing should be staggered 600mm by fixing to different studs.
- Adhesive must not be applied to the sheet edges or under screws or nails. This may lead to screw or nail popping.
- All joints between sheets should be touch fitted.

#### Fastening the Linings

- Leave a 5–10mm gap at the floor level to allow for movement in timber framing.
- Apply adhesive to intermediate studs at maximum 300mm centres.
- Fix the top sheet first.
- Screws or nails should be fixed no less than 12mm from the sheet edge.
- Place the fasteners at the wall corners in a room at 50mm in from each direction.
- Single screw or nail fastenings at 300mm centres to top and bottom plates and sheet ends. Screw or nail single fastenings through the centre of the wall at the point where the horizontal joint crosses the stud.
- Screw or nail fasteners at 300mm centres around all wall openings.
- Firmly press the plasterboard where adhesive has been applied to ensure full contact.

Fasteners	10mm	13mm
Coarse Thread Drywall Screws	25mm x 6 gauge	32mm x 6 gauge
Drywall Nails	30mm x 2.8mm	30mm x 2.8mm

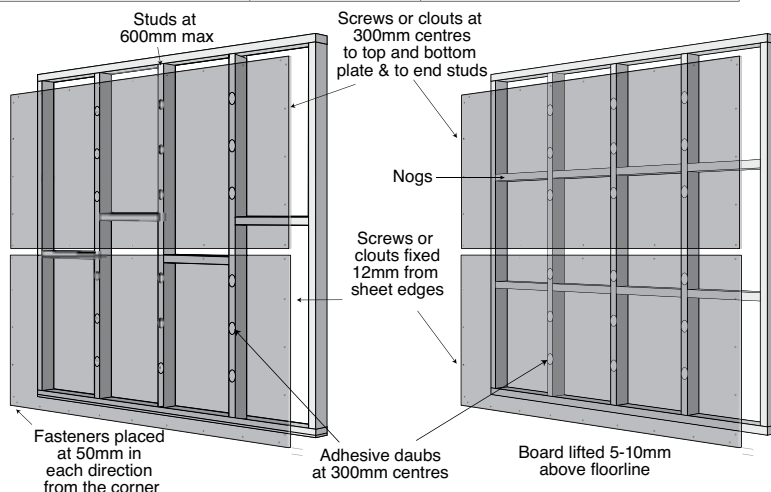



## GENERAL WALL AND CEILING INSTALLATION

### Fixing to Walls – Timber Frame Vertical Method

#### Wall Framing

Dimensions for framing must comply with NZS3604:2011 requirements.

- Timber Framing moisture content should be between 12-18% when lining is installed.
- Studs must be spaced at 600mm centres maximum when using either 10mm or 13mm Elephant Plasterboard.
- For wall heights at 2400mm high, nogs need to be set at 800mm centres.
- For wall heights at 2700mm high, nogs need to be set at 900mm centres.

#### Fastening the Linings

- Leave a 5–10mm gap at the floor level to allow for movement in timber framing.
- Apply adhesive to intermediate studs at maximum 300mm centres.
- Firmly press the plasterboard where adhesive has been applied to ensure full contact.
- Fasteners should be at 300mm centres around the sheet perimeter.
- Screws or nails should be fixed no less than 12mm from the sheet edge.
- Adhesive must not be applied to the sheet edges or under nails or screws. This may lead to nail or screw popping.
- All joints between sheets should be touch fitted.

Fasteners	10mm	13mm
Coarse Thread Drywall Screws	25mm x 6 gauge	32mm x 6 gauge
Drywall Nails	30mm x 2.8mm	30mm x 2.8mm

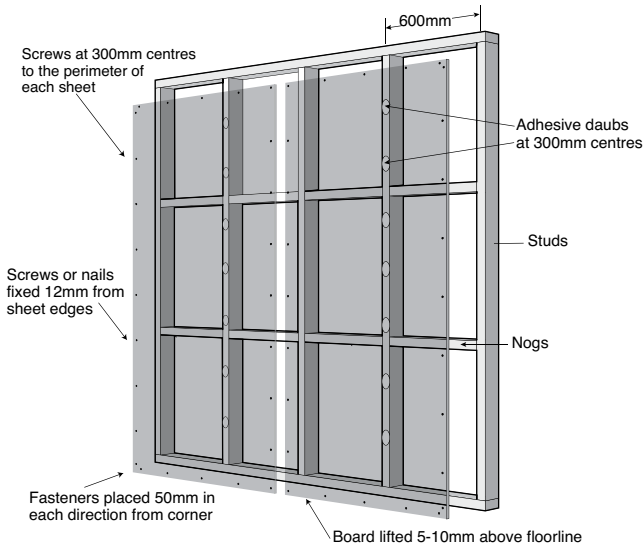

## Fixing to Walls – Steel Framing Horizontal Method

### Wall Framing

- Steel stud dimensions should be 63 x 34 x 0.55mm minimum with a 6mm return.
- Steel channel dimensions should be 63 x 30 x 0.55mm minimum.
- Stud spacing should be at 600mm centres maximum.
- Studs need to be placed with the open side facing in the same direction.
- The correct order for attaching the board is crucial, as the face of the steel stud can deflect initially.

The first board will deflect slightly when attached to the open side of the stud, but when the screw is fully tightened it will pull back tight against the board. There will be minimal deflection when the second sheet is attached, as the open flange is now supported by the first one. Support the stud to avoid twisting.

### Fastening the Linings

- Leave a 5–10mm gap at the floor level. Sheets can be fixed hard to the floor if friction fitted steel studs used.
- Apply adhesive or screws to intermediate studs at maximum 300mm centres.
- Screws should be fixed no less than 12mm from the sheet edge.
- Screw single fastenings at 300mm centres to top and bottom channels and at end studs.
- Single screw to each stud where the horizontal joint crosses the studs.
- Joints made on framing should be staggered 600mm by fixing to different studs.
- Adhesive must not be applied to sheet edges or under screws. This may lead to screws popping.
- All joints between sheets should be touch fitted.
- For stud heights greater than 2.4m we recommend 13mm Plasterboard or greater.

#### Fasteners

Self-Tapping Drywall Screws	25mm x 6 gauge
-----------------------------	----------------

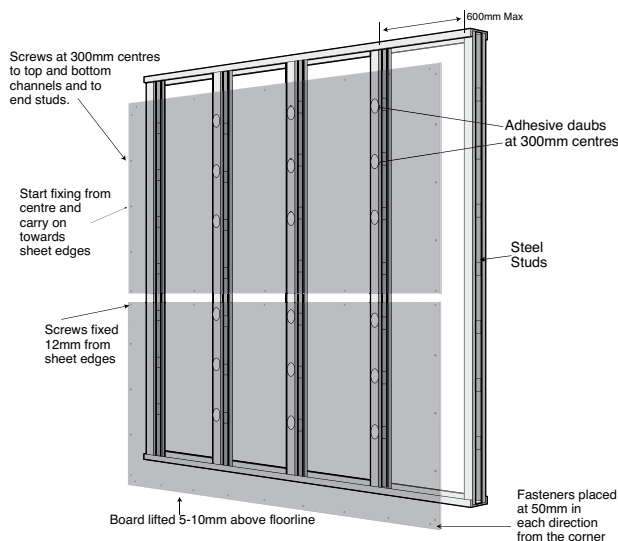



## GENERAL WALL AND CEILING INSTALLATION

### Fixing to Walls – Steel Framing Vertical Method

#### Wall Framing

- Steel Stud dimensions should be 63 x 34 x 0.55mm minimum with a 6mm return.
- Steel channel dimensions should be 63 x 30 x 0.55mm minimum.
- Stud spacing should be at 600mm centres maximum.
- Studs need to be placed with the open side facing in the same direction.

The correct order for attaching the board is crucial, as the face of the steel stud can deflect initially. The first board will deflect slightly when attached to the open side of the stud, but when the screw is fully tightened it will pull back tight against the board. There will be minimal deflection when the second sheet is attached, as the open flange is now supported by the first one. Support the stud to avoid twisting.

#### Fastening the Linings

- Leave a 5–10mm gap at the floor level. Sheets can be fixed hard to the floor if friction fitted steel studs used.
- Apply adhesive or screws at maximum 300mm centres to intermediate studs.
- Screws should be fixed at no less than 12mm from the sheet edge.
- Start fixing from the sheet centre and work out towards the edge.
- Adhesive must not be applied to the sheet edges or under screws. This may lead to screw popping.
- Joints should be staggered 600mm on opposite sides of the partition.
- All joints between sheets should be touch fitted.
- For stud heights greater than 2.4m we recommend 13mm Plasterboard or greater.

#### Fasteners

Self-Tapping Drywall Screws	25mm x 6 gauge
-----------------------------	----------------

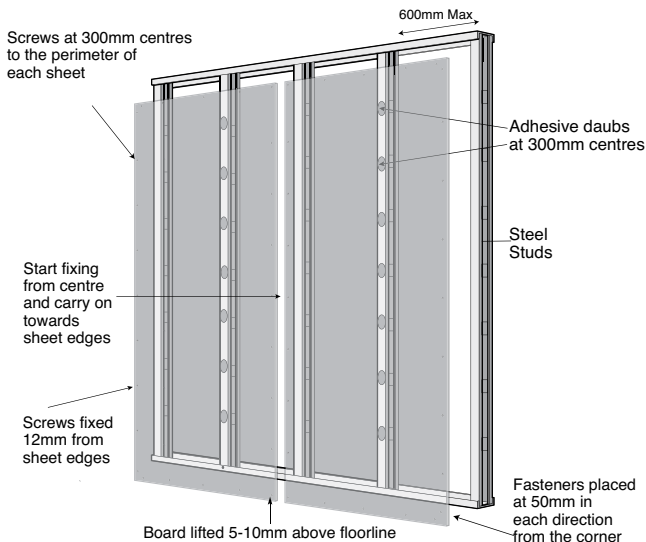



## GENERAL WALL AND CEILING INSTALLATION

### Back-blocking

#### General

Back-blocking is a reinforcing system designed to minimise the deformation and cracking of joints which can occur from a combination of weather conditions and/or building stresses resulting from expansion, contraction or building movement. Back-blocking is generally used where butt or end jointing of sheets occur between framing members and to recessed joints where a high standard of finish is required.

- Do not use panel adhesives for back-blocking as they have high flexibility characteristics.

#### Ceiling recessed edge joints

- Cut back-blocks at least 200mm wide and long enough to fit loosely between the framing members.
- Apply plaster-based setting type adhesive/cement to back-blocks over the full face of the back-block.  
A notched spreader to give 6mm x 6mm beads at approximately 20mm centres at right angle to the joint would be satisfactory.
- Fix Elephant Plasterboard at right angles to framing members. Place back-blocks centrally along the full length of the board end or edge.
- Immediately after the blocks are in place erect the next board.
- Ceilings back-blocks may be cemented into position from above the ceiling after the boards have been fixed and before they are flush jointed.

### Back-blocking for Ceilings and Walls

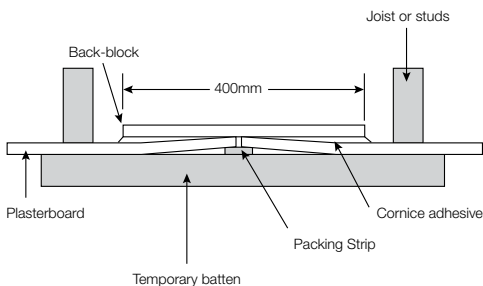

**Table 1** Requirements for Back-blocking

Level of Finish	Ceilings		Walls	
	Butt	Recessed	Butt	Recessed
5	Yes	Yes	Yes	No
4	Yes	Yes*	No	No
3	No	No	No	No

\*Recessed joints on ceiling must be back-blocked in any area containing 3 or more recessed joints.



## GENERAL WALL AND CEILING INSTALLATION

### Back-blocking

#### Ceiling Butt Joints

- Fix ceiling sheets with ends butted neatly together. The butt joint shall fall within 50mm of the mid-span point between framing members.
- Use battens and packers to support and deflect the sheet ends upwards about 2mm.
- Reinforce the butt joint by back-blocking with Elephant Plasterboard cut to fit loosely between the framing across the full width of the sheet and overlapping the edges of adjoining sheets by 50mm.
- Adhere back-blocks with plaster-based setting type adhesive/cement applied over the full face of the back-block. A notched spreader to give 6 x 6mm beads at approximately 20mm centres at right angle to the joint would be satisfactory.
- Allow adhesive/cement to set for a minimum of 24 hours before removing temporary battens. When temporary battens are removed, a hollow formation suitable for jointing remains.
- Back-blocking of sheet ends and recessed joints is essential for a high quality finish. Joints made on framing should be staggered 600mm by fixing to different battens or joists.

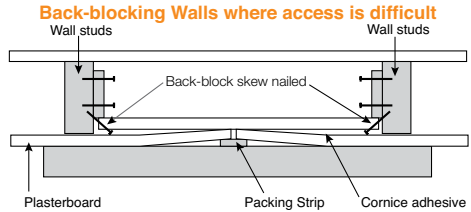
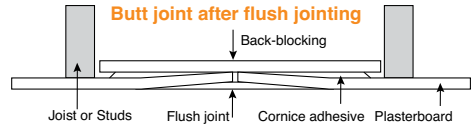

### Curving Elephant Plasterboard

Elephant Plasterboard can be formed to provide curved surfaces to fit various interior wall and ceiling designs.

- Sheets are to be applied horizontally to walls.
- If sheets are required to be wet then the face that is to be compressed should have water applied with a roller prior to application.
- Allow wet boards to set for 1 hour prior to application.
- Allow 1 litre of water for every 3 sqm of board.
- As the sheets dry the board should retain its original hardness along with its new curve.
- To avoid flat areas between framing, studs may need to be spaced closer than normal.
- Penetrations are not recommended for curved surfaces.
- Adhesive must not be used for fixing damp sheets.

### Minimum Bending Radius of Elephant Plasterboard

Board Thickness mm	Minimum Radius – Wet	Minimum Radius – Dry
10mm Standard-Plus	1050mm	1400mm
13mm Standard-Plus	1200mm	1700mm

### Minimum Vertical Stud Spacings – Radius of Curve (mm)

Over 1000–1500	Over 1500–3000	Over 3000
200	300	400

## GENERAL WALL AND CEILING INSTALLATION

### Concrete and Masonry Walls

#### General

Before commencing application a true plane must be established. Where irregularities occur use either plasterboard strips as packing, or Timber/Steel Furring channel.

- Apply adhesive 40mm from the sheet edges to avoid excess adhesive squeezing out through the joint.
- Ensure that sheets are applied within the setting time of the adhesive.
- All joints between sheets should be touch fitted.

#### Direct Bonding

- Masonry surface must be free of flaking paint, efflorescence, dust or any material that may impair the adhesive bonding.
- Apply daubs of adhesive at vertical and horizontal spacings of 300–400mm.
- Adhesive daubs should be approx 50mm in diameter and 10mm thick.
- Sheets should be firmly pressed into position ensuring full contact with adhesive. Hold sheets in position by shoring or other temporary fixing until adhesive has set.
- Cut Elephant Plasterboard sheets to allow a 10mm gap at the top.
- When adhesive has set remove shoring and carry out flush jointing.
- Control joints in walls must be carried through the plasterboard.

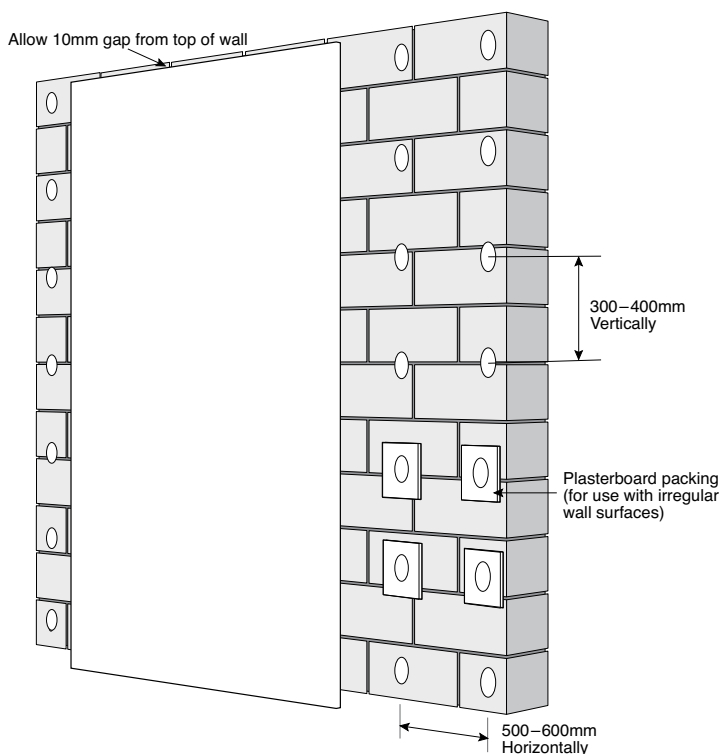



## GENERAL WALL AND CEILING INSTALLATION

### Concrete and Masonry Walls

#### Fixing Timber Batten or Steel Furring Channel

- Fix timber/steel furring channel vertically at 600mm centres with suitable fasteners and pack to achieve a true plane where necessary.
- Fix short lengths of timber/steel furring channel at top and bottom leaving a 10mm ventilation gap between ends and main furring.
- Fixing details are as described for fixing Elephant Plasterboard to timber or steel frames.

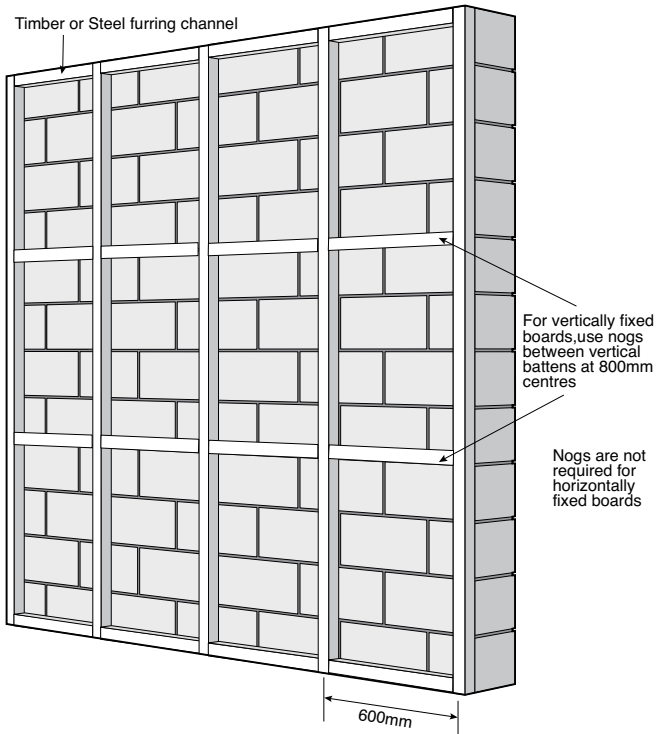



## Notes

---

---

---

---

---

---

---

---

---

---

---

---

---

---

---

---

---

---

---

---

---

---

---



## QuickBrace™ Numbering System

E = Elephant Plasterboard

H = Panel Hold-downs Required *(example shown)*

N = No Hold-downs

System Number  
Example only

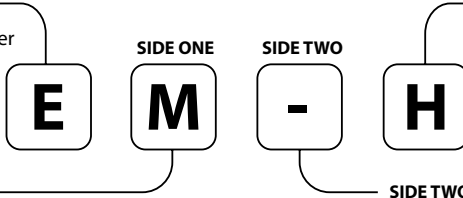

**SIDE ONE**

S = Elephant Standard-Plus

M = Elephant Multiboard *(example shown)*

**SIDE TWO**

- = Single sided system only *(example shown)*

S = Elephant Standard-Plus

P = Plywood

## QuickBrace™ Systems & Performance Table

System Number	Lining Requirement	Min. Length (m)	BU/m		Panel Hold-downs
			Wind	EQ	
<b>Plasterboard on One Side</b>					
<b>ES-N</b>	Elephant Standard-Plus on one side	0.4	65	60	No
		1.2	70	65	
		1.8	80	65	
<b>ES-H</b>	Elephant Standard-Plus on one side	0.4	80	75	Yes
		0.8	100	85	
		1.8	115	85	
<b>EM-H</b>	Elephant Multiboard on one side	0.4	95	100	
		0.8	120	110	
		1.2	140	115	
<b>Plasterboard on Both Sides</b>					
<b>ESSN</b>	Elephant Standard-Plus on both sides	0.4	80	75	No
		0.8	90	80	
		1.2	95	85	
<b>ESSH</b>	Elephant Standard-Plus on both sides	0.4	95	110	Yes
		0.8	140	130	
		1.2	150	140	
<b>EMSH</b>	Elephant Multiboard on one side Elephant Standard-Plus on the other	0.4	110	115	
		0.8	140	135	
		1.2	150	145	
<b>Plasterboard One Side, Plywood the Other</b>					
<b>ESPH</b>	Elephant Standard-Plus on one side Plywood on the other	0.4	100	115	Yes
		0.8	140	140	
		1.2	150	150	
<b>EMPH</b>	Elephant Multiboard on one side Plywood on the other	0.4	120	135	
		0.8	140	145	
		1.2	150	150	



## Wall & Ceiling Construction Details

### Wall Framing

Framing is to comply to NZS 3604:2011 and must be a minimum of 70 x 45mm for internal walls and 90 x 35mm for external walls.

Nogs or dwangs are not a requirement in order to achieve the bracing ratings published in this document.

### Fastening Bracing Elements to Floors

System Number	Bottom Plate Fixing Requirements		
	Concrete Floors		Timber Floors
	External Walls	Internal Walls	External or Internal Walls
ES-N	Fix as per NZS 3604:2011	Fix as per NZS 3604:2011. Alternatively see <b>Note 1</b> below	Pairs of 100 x 3.75mm hand driven flat head nails or three 90 x 3.15mm power driven nails at 600mm centres all in accordance to NZS 3604:2011
ESSN	Not applicable		
ESSH EMSH	Not applicable	Fix as per NZS 3604:2011	Pairs of 100 x 3.75mm hand driven flat head nails or three 90 x 3.15mm power driven nails at 600mm centres all in accordance to NZS 3604:2011
ES-H EM-H ESPH EMPH	Fix as per NZS 3604:2011		Panel End Hold downs at each end of the bracing element.

Note 1: Min 75 x 3.8mm shot-fired fasteners with 16mm discs at 150mm & 300mm from end studs and thereafter at 600mm centres. Ensure a minimum penetration of 30mm into the concrete foundation.

### Top Plate Connections

Top plate connections detailed below meet the requirements of NZS 3604:2011 clause 8.7.3 Joints in plates. The joints must be over a stud or solid blocking. A 6kN connection is required if any bracing element in the wall exceeds 100 bracing units. Otherwise a 3kN connection is adequate.

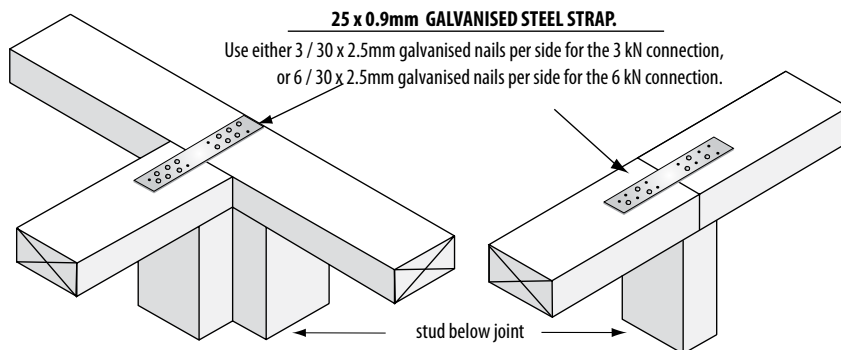



# ELEPHANT PLASTERBOARD BRACING SYSTEMS

## Panel End Hold Downs (Bracing Anchor Brackets Details)

Either Pryda® Bracing Anchor or any other proprietary panel end hold down bracket with a minimum performance of 15kN.

### Concrete Floors

M12 galvanised anchor bolt or proprietary equivalent with minimum characteristic strength of 15kN .  
Set no less than 75mm into the concrete.

### Timber Floors

M12 x 150mm galvanised coach screw or proprietary equivalent with minimum characteristic strength of 12kN.

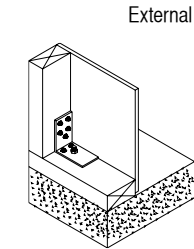

External

Locate the bracket flush with the inside face of the framing in order to maximise concrete edge distance.

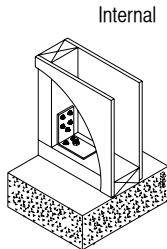

Internal

Locate the bracket centrally on the bottom plate.

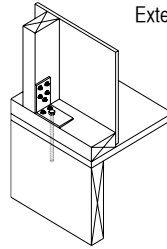

External

Full depth solid blocking centrally positioned beneath the coach screw.

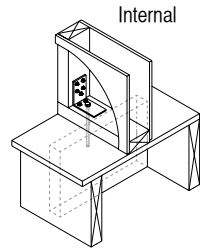

Internal

Locate the bracing anchor bracket so that the coach screw is centred over the timber below.

## Panel End Hold Downs (Bracing Strap & Bolt Details)

N.B. Bottom plate anchor placements have been reduced to 80mm from the end of the bracing element. This is to be consistent with the bolt location when using bracing anchors brackets and represents industry best practise. This does not effect previous designs or installations.

### Bracing Strap:

400 x 25 x 0.9mm galvanised strap passing under the bottom plate. Six 30 x 2.5mm galvanised flat head nails to each side of the stud and three 30 x 2.5mm galvanised flat head nails to each side of the bottom plate.

The bracing strap should be checked into the framing in order to make the substrate flush when receiving the plasterboard lining.

Position it in such a way that the important corner fastenings of the bracing element are not affected by it. Keeping the strap to the edge of the end stud as shown on the next page will ensure the important corner fastenings won't penetrate the bracing strap.

Extra thickness and/or corrosion protection may be required on exposed and unexposed sites as per requirements of NZS 3604:2011

**Refer to figures on the next page**





# ELEPHANT PLASTERBOARD BRACING SYSTEMS

## Panel End Hold Downs (Bracing Strap & Bolt Details)

### Concrete Floors

M12 x 150mm galvanised bolt or proprietary equivalent with minimum characteristic strength of 15kN.

Set no less than 75mm into the concrete.

Allow for a 3 x 50 x 50mm galvanised washer within 105mm of the ends of the bracing element.

External

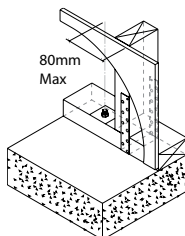

Internal

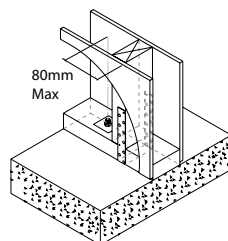

### Timber Floors

M12 x 150mm galvanised coach screw or proprietary equivalent with minimum characteristic strength of 12kN.

Allow for a 3 x 50 x 50mm galvanised washer within 105mm of the ends of the bracing element.

External (Option A)

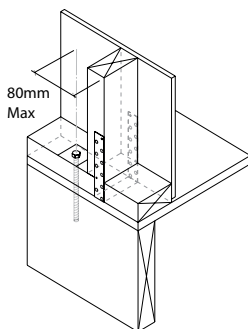

Internal

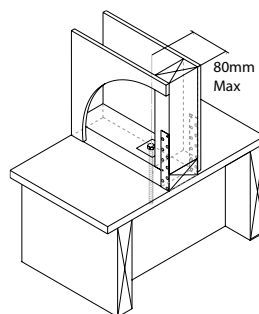

External (Option B)

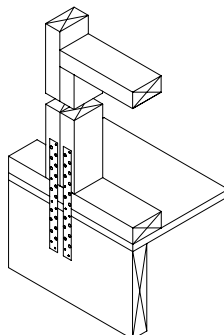

### Timber Floor: External

(Option B)

Block up to the first nog to allow for double strapping using three 100 x 3.75mm nails.

Two 300 x 25 x 0.9mm galvanised straps pass down onto the floor joist. Six 30 x 2.5mm galvanised flat head nails to each stud and the floor joist and three to the bottom plate.



## Intersecting Walls

Provided the minimum wall lengths are complied with and walls are constructed as described in this guide, bracing elements may be interrupted by intersecting walls as detailed below. Fasteners layout at the corners and around the perimeter of the bracing elements are as per the figures on page 29. Joints between sheets shall be paper taped and stopped in accordance with this guide. Panel end hold-downs must also comply except that the location of bottom plate anchors is modified for L and T intersections as defined below.

The minimum bracing element length is 900mm for single sided bracing systems (ES-N, ES-H and EM-H) and 600mm for double sided bracing systems, (ESSN, ESSH, ESPH, EMSH and EMPH.)

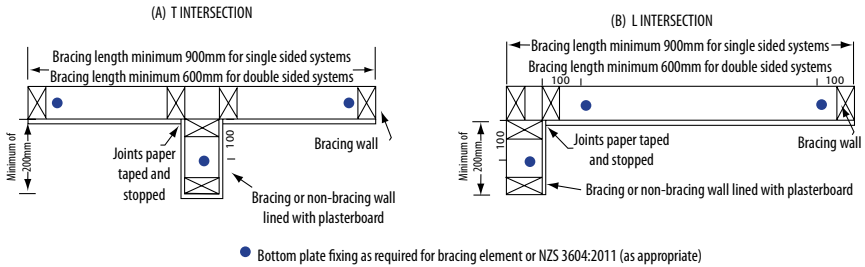

## Parapets, Gable End Walls or Dropped or Suspended Ceilings

Sheeting material used in bracing elements must connect to both the top and bottom plates. Where the top plate is not accessible, fixing to a row of noggs is not an acceptable solution. Detailed below are two possible solutions.

A continuous length of timber or ribbon plate, with the same minimum size as the bottom plate, fixed across the face of the studs just above the row of noggs and at the ceiling line.

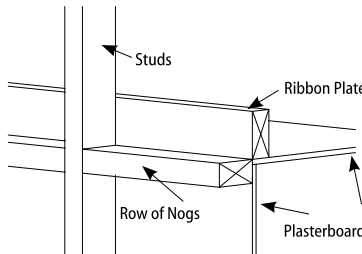

A metal angle of minimum of 50 x 50 x 0.55mm fixed to the row of noggs at the ceiling line. Use minimum 30 x 2.5mm FH galv nails at 300mm centres.

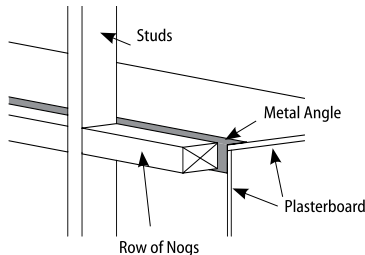



# ELEPHANT PLASTERBOARD BRACING SYSTEMS

## Ceiling Diaphragms

Ceiling diaphragms are required to comply with Section 5.6 and 13.5 of NZS 3604:2011. Ceiling diaphragms are required when distances between bracing lines exceed 6m (when dragon ties not used) or 7.5m if dragon ties provide lateral support to the external walls (as per figure 8.1 in NZS 3604:2011).

Ceiling diaphragms shall not exceed 12m in length and the length shall not exceed twice the width (both length and width being measured between supporting walls). The ceiling lining shall cover the entire area of the ceiling diaphragm.

### Ceiling Diaphragm Systems

**C1:** Not steeper than 15 degrees and not longer than 7.5m

**C2:** Not steeper than 25 degrees and not longer than 12m  
or Not steeper than 45 degrees and not longer than 7.5m

### Plasterboard Lining Requirement:

Minimum 10mm Elephant Standard-Plus Plasterboard

### Framing members:

Ceiling battens shall be spaced at maximum;

600mm centres for 10mm or 13mm Elephant Plasterboard

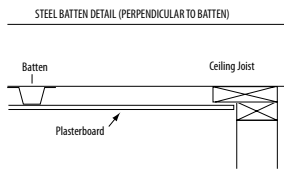
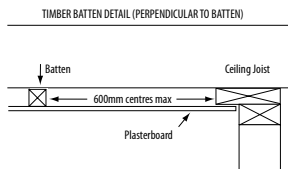
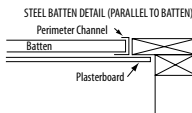
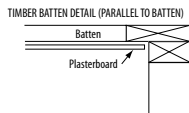
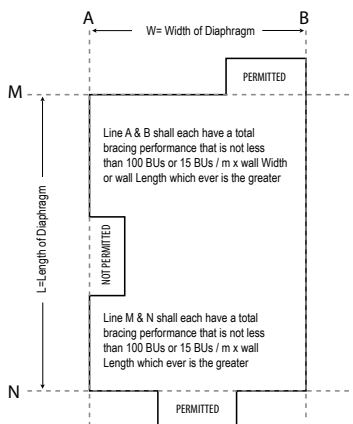

## Timber or Steel Battens

### Timber battens:

Must be fixed according to NZS 3604:2011.

**Steel battens:** Minimum 0.55 BMT thickness with flanges not less than 8mm in order to allow the direct screwing using 2/32mm x 8g waver head self tapping screws to the ceiling framing members.

A steel perimeter channel or metal angle is required to receive the ends of the steel battens.

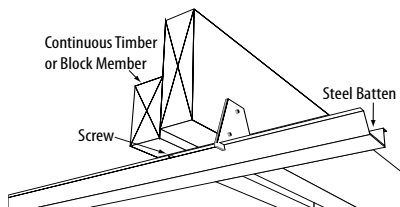

If a clip system is used then a solid timber block or continuous timber member must be fixed to the framing member.

The linings must be fastened to solid continuous timber member at the perimeter of the ceiling diaphragms. This is achieved with either at 140mm double top plate or by fixing continuous timber member to the original top plate using fixing requirements for built up members and nailed together according to NZS 3604:2011 clause 2.4.4.7



# ELEPHANT PLASTERBOARD BRACING SYSTEMS

## Ceiling Construction Details

### Coved Ceilings

Ceilings diaphragms with more than one gradient are allowable, by using metal folded angles with a minimum gauge of 0.55 BMT at the junctions.

Use 32mm x 6g course thread drywall screws when fixing to timber battens and use 32mm x 8g drywall self tapping screws or similar when fixing to steel battens.

The plasterboard is fixed to these folded metal angles at 75mm or 100mm or 150mm centres depending on conditions detailed on right. Use 25mm x 6g drywall self tapping screws.

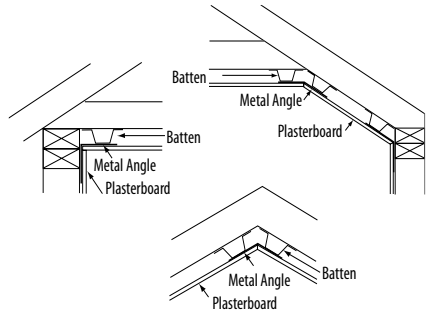

### Minimum sheet size requirements:

Minimum sheet size shall be 900mm wide by 1800mm long where possible except where building dimensions prevent their use. Sheets between 600mm wide and 900mm wide by between 1200mm long and 1800mm long can be used provided they are back blocked with adjacent sheets.

### Openings in Ceiling Diaphragms:

Openings are allowable and must be within the middle third of the diaphragms length and width and no opening dimension shall be greater than the ceiling diaphragm width. Fix sheets at 150mm centres minimum to opening trimmers. Refer to Openings in Bracing Elements on page 30.

### Fasteners:

Timber battens & Timber perimeters: 32mm x 6g High thread Drywall screws

Steel battens and Steel perimeter: 25mm x 6g Self Tapping Drywall screws

### Fastener Brands Allowable:

Fortress ® , Grabber® or Senco ®. (Other brands need to demonstrate equal or better performance).

### Fastening Centres

The corner pattern fastening centres are as follows; Place fasteners 50mm, 50mm, 50mm, 75mm, 75mm from all corners of the diaphragm.

### For ceiling diaphragms not steeper than 15 degrees and not longer than 7.5m;

Place fasteners at maximum 150mm centres to the boundary members and around the perimeter of the diaphragm as per ceiling diaphragm pattern C1 on the right.

### For ceiling diaphragms that are:

either not steeper than 25 degrees and not longer than 12.0m

or not steeper than 45 degrees and not longer than 7.5m

Place fasteners at maximum 100mm centres to the boundary members and around the perimeter of the diaphragm as per ceiling diaphragm pattern C2 on the right.

Fix all fasteners at no less than 12mm from paper bound sheet edges and 18mm from sheet ends or cut edges.

Fastening requirements within the ceiling diaphragm are conventional.

All in accordance with this guide.

### Jointing:

All joints shall be paper tape reinforced and stopped. Sheet end butt joints should be between the battens and back blocked.

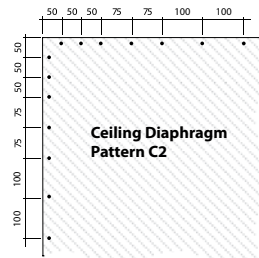
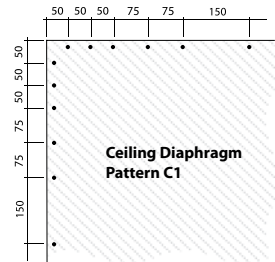



# ELEPHANT PLASTERBOARD BRACING SYSTEMS

## Wall Bracing Construction Details

### Fastening the Plasterboard Linings

Elephant Plasterboard designated as a bracing element must be constructed with specified fasteners and fastener patterns. Specialised panel end hold downs may also be required as they are essential for obtaining the bracing unit ratings. The corner detail for plasterboard bracing elements require specific increased fastening.

#### Fasteners:

Timber battens & Timber perimeters: 32mm x 6g High thread Drywall screws

Steel battens and Steel perimeter: 25mm x 6g Self Tapping Drywall screws

#### Fastener Brands Allowable:

Fortress ® ,Grabber® or Senco ®. (Other brands need to demonstrate equal or better performance).

### Corner & Perimeter Fastener Pattern

Refer to the Condensed Bracing Corner Pattern on the right.

- All four corners of an Elephant Plasterboard bracing element requires the specialised condensed pattern.
- The bracing element perimeter is then fastened at 150 centres
- Place all fasteners 12mm from paper bound sheet edges and 18mm from sheet ends or cut edges.
- Fastening the middle of the bracing element is as per the recommended screw and glue methods.

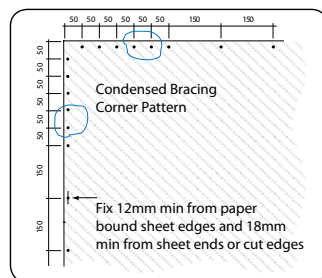

### Minimum Sheet Size

Sheets less than 300mm wide are allowable provided that the joints form over solid framing or the sheet is back blocked. All joints must be paper taped and stopped.

### Butt Joints

All butt joints should be either fitted over nogs or studs and fastened at 200mm centres or back-blocked. All joints must be paper taped and stopped.

### Horizontal Fixing

QuickBrace™ systems may be fixed horizontally. The specialised corner and perimeter bracing pattern need only to be placed over the length and width of the bracing element. Fastening in the field of the bracing element is as per the recommended glue and screw method.

Note- Care should be taken during the installation of the plasterboard, as often the studs that require the special mechanical fixing pattern are in the field of the sheet. It is important to insure that the adhesives are not placed on or near the studs that require these special perimeter fasteners as this can be a cause of screw popping.

### Alternative Corner fastener layout

If the installer has used the 50, 50, 50, 75, 75, 150 corner screw pattern then this can easily be remedied by simply placing an extra screw between the first 150mm (where possible).

Refer to the Alternative Condensed Bracing Corner Pattern on the right.

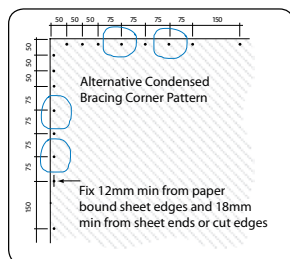



# ELEPHANT PLASTERBOARD BRACING SYSTEMS

## Wet Areas

Do not place bracing elements in areas such as behind showers and baths. Placing bracing elements in water splash areas is acceptable provided that these areas are maintained impervious for the life of the building. Bracing elements require a 50 year durability.

## Allowable Substitutions

Elephant Aquaboard can be substituted for the Elephant Standard-Plus in QuickBrace™ systems ES-N, ESSN, ES-H, ESSH, ESPH and EMSH.

Elephant Aquaboard can be substituted for the Elephant Multiboard in QuickBrace™ systems EM-H, EMSH and EMPH provided that the element is 600mm or longer and the perimeter screw pattern is reduced to 100mm centres.

Ensure that all other relevant bracing system requirements including the important corner patterns are met.

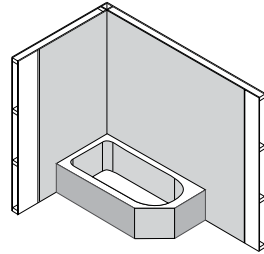

*Shaded area must not have Plasterboard Bracing Systems*

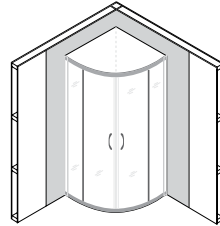

## Openings in Bracing Elements

Large openings can only be placed in the middle 1/3 of the bracing element.

Neither the opening height nor length can be more than 1/3 of the bracing element height. Fix the wall linings around the opening trimmers at 150mm centres.

Smaller openings of 90 x 90mm or less are allowable but cannot be placed closer than 90mm from the edge of the bracing element.

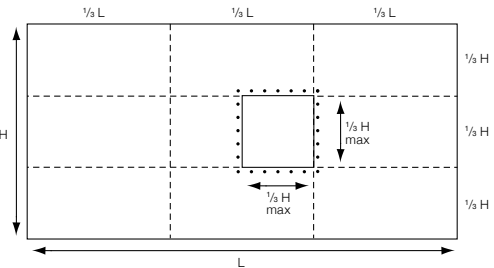

## Plywood

For systems ESPH and EMPH plywood is required. This can be Grade D-D 7mm construction plywood at a minimum. The plywood must be manufactured as per Australian/New Zealand Standard AS/NZS 2269:2004. The nailing pattern is at 150mm centres around the perimeter of the bracing element or each plywood sheet, whichever is the lesser width, using 50 x 2.8mm Flat head galvanised or stainless steel nails.

Sheet edges must be supported by framing or blocking. The corner pattern fastening is conventional and there is no need for the specialised corner patterns as is required on the plasterboard side of the brace.

## Renovations

When relining walls during renovations, check the building plans to ensure that all the bracing elements are reinstated



# ELEPHANT PLASTERBOARD BRACING SYSTEMS

## Plasterboard on One Side

System Number	Lining Requirement	Min Length (m)	BU/m		Panel Hold-downs	Bracing Corner Pattern
			Wind	Earth-quake		
ES-N	Elephant Standard-Plus on One side	0.4	65	60	No	
		1.2	70	65		
		1.8	80	65		
ES-H	Elephant Standard-Plus on One side	0.4	80	75	Yes	
		0.8	100	85		
		1.8	115	85		
EM-H	Elephant Multiboard on One side	0.4	95	100		
		1.2	140	115		

### Framing

Framing heights and dimensions to comply with NZS 3604:2011 and must be a minimum of 70 x 45mm for internal walls and 90 x 35mm for external walls. Nogs and Dwargs are not a requirement in order to achieve the bracing ratings in this document.

Refer to relevant sections and clauses of

NZBC B1: Structure; AS1 Clause 3 Timber -NZS 3604

NZBC B2: Durability; AS1 Clause 3.2 Timber -NZS 3602

### Fastening Bracing Elements To Floor

**Timber Floor:** Fastening within the bracing element must be done in accordance with NZS 3604:2011.

i.e. Either pairs of 100 x 3.75mm hand driven nails or three 90 x 3.15mm power driven nails at 600mm centres.

For **ES-H** and **EM-H**: Use the panel hold downs at each end of the bracing element.

**Concrete Floors:** External or Internal walls: Within the bracing element fix the bottom plate as per NZS 3604:2011

For **ES-N**: On Internal Walls alternatively use 75 x 3.8mm shot-fired fasteners with 16mm discs at 150mm & 300mm from end studs and thereafter at 600mm centres. Ensure a minimum penetration of 30mm into the concrete foundation.

For **ES-H** and **EM-H**: Use the panel hold downs at each end of the bracing element.

### Wall Lining (As Per Specified System Above)

One layer of Plasterboard lining type as per specified system above to ONE side of frame.

The Plasterboard sheets can be fixed vertically or horizontally. Use full height or full length sheets when fixing vertically or horizontally where possible. All sheet end butt joints must be fixed over solid timber framing and fastened at 200mm centres. Alternatively the sheet end butt joints may be back blocked. Sheets shall be touch fitted.

### Fixing of Plasterboard Linings

#### Fastening: (Corners And Perimeters Of The Bracing Element)

32mm x 6g High thread Drywall screws (Fortress® or Grabber® or Senco®)

#### Fastening Centres: (Corners and Perimeters of the bracing element)

Corner Pattern: Refer to the bracing corner pattern above.

Perimeter Pattern: Place fasteners at 150mm centres around perimeter of bracing element.

Place all fasteners 12mm from paper bound sheet edges and 18mm from sheet ends or cut edges.

#### Fasteners and Fastening Centres in the Field of the bracing element

For vertically fixed sheets place fasteners at 300mm centres to the intermediate sheet joints. For Horizontally fixed sheets place fasteners at the sheet edge that crosses the studs. Place daubs of Drywall adhesives at 300mm centres to intermediate studs. Take extra care to ensure that screws or nails are not placed closer than 200mm from any daubs of adhesive.

### Jointing

All fasteners stopped and all sheet joints reinforced with paper jointing tape.



# ELEPHANT PLASTERBOARD BRACING SYSTEMS

## Plasterboard On Both Sides

System Number	Lining Requirement	Min Length (m)	BU/m		Panel Hold-downs	Bracing Corner Pattern
			Wind	Earth-quake		
ESSN	Elephant Standard-Plus on Both sides	0.4	80	75	No	
		1.2	95	85		
ESSH	Elephant Standard-Plus on Both sides	0.4	95	110	Yes	
		1.2	150	140		
EMSH	Elephant Multiboard on One side, Elephant Standard-Plus on the Other	0.4	110	115		
		1.2	150	145		

### Framing

Framing heights and dimensions to comply with NZS 3604:2011 and must be a minimum of 70 x 45mm for internal walls and 90 x 35mm for external walls. Nogs and Dwangs are not a requirement in order to achieve the bracing ratings in this document.

Refer to relevant sections and clauses of

NZBC B1: Structure; AS1 Clause 3 Timber -NZS 3604

NZBC B2: Durability; AS1 Clause 3.2 Timber -NZS 3602

### Fastening Bracing Elements To Floor

**Timber Floor:** Fastening within the bracing element must be done in accordance with NZS 3604:2011.

i.e. Either pairs of 100 x 3.75mm hand driven nails Or three 90 x 3.15mm power driven nails at 600mm centres.

For **ESSH** and **EMSH**: Use the panel hold downs at each end of the bracing element.

**Concrete Floors:** Within the bracing element fix the bottom plate as per NZS 3604:2011.

For **ESSN**: For Internal Walls alternatively use 75 x 3.8mm shot-fired fasteners with 16mm discs at 150mm & 300mm from end studs and thereafter at 600mm centres. Ensure a minimum penetration of 30mm into the concrete foundation.

For **ESSH** and **EMSH**: Use the panel hold downs at each end of the bracing element.

### Wall Lining (As Per Specified System Above)

One layer of Plasterboard lining type as per specified system above to BOTH sides of frame. The Plasterboard sheets can be fixed vertically or horizontally. Use full height or full length sheets when fixing vertically or horizontally where possible. All sheet end butt joints must be fixed over solid timber framing and fastened at 200mm centres. Alternatively the sheet end butt joints may be back blocked. Sheets shall be touch fitted.

### Fixing of Plasterboard Linings

#### Fastening: (Corners and Perimeters of the bracing element)

32mm x 6g High thread Drywall screws (Fortress® or Grabber® or Senco®)

#### Fastening Centres: (Corners and Perimeters of the bracing element)

Corner Pattern: Refer to the bracing corner pattern above.

Perimeter Pattern: Place fasteners at 150mm centres around perimeter of bracing element.

Place all fasteners 12mm from paper bound sheet edges and 18mm from sheet ends or cut edges.

#### Fasteners and Fastening Centres in the Field of the bracing element

For vertically fixed sheets place fasteners at 300mm centres to the intermediate sheet joints. For Horizontally fixed sheets place fasteners at the sheet edge that crosses the studs. Place daubs of Drywall adhesives at 300mm centres to intermediate studs. Take extra care to ensure that screws or nails are not placed closer than 200mm from any daubs of adhesive.

### Jointing

All fasteners stopped and all sheet joints reinforced with paper jointing tape.





# ELEPHANT PLASTERBOARD BRACING SYSTEMS

## Plasterboard On One Side, Plywood The Other

System Number	Lining Requirement	Min Length (m)	BU/m		Panel Hold-downs	Bracing Corner Pattern
			Wind	Earth-quake		
ESPH	Elephant Standard-Plus on One Side Plywood on the Other Side	0.4	100	115	Yes	
		0.8	140	140		
		1.2	150	150		
EMPH	Elephant Multiboard on One Side Plywood on the Other Side	0.4	120	135		
		0.8	140	145		
		1.2	150	150		

### Framing

Framing heights and dimensions to comply with NZS 3604:2011 and must be a minimum of 70 x 45mm for internal walls and 90 x 35 mm for external walls. Nogs and Dwangs are not a requirement in order to achieve the bracing ratings in this document. Refer to relevant sections and clauses of

NZBC B1: Structure; AS1 Clause 3 Timber -NZS 3604

NZBC B2: Durability; AS1 Clause 3.2 Timber -NZS 3602

### Fastening Bracing Elements To Floor

**Timber Floor:** Fastening within the bracing element must be done in accordance with NZS 3604:2011.

i.e. Either pairs of 100 x 3.75mm hand driven nails or three 90 x 3.15 power driven nails at 600mm centres.

For **ESPH** and **EMPH**: Use the panel hold downs at each end of the bracing element

**Concrete Floors:** Within the bracing element fix the bottom plate as per NZS 3604:2011.

For **ESPH** and **EMPH**: Use the panel hold downs at each end of the bracing element

### Wall Lining (As Per Specified System Above)

One layer of Plasterboard lining type as per specified system above to one side of frame. One layer of 7mm D-D Plywood as per specified system above to other side of frame. The Plasterboard sheets can be fixed vertically or horizontally. Use full height or full length sheets when fixing vertically or horizontally where possible. All sheet end butt joints must be fixed over solid timber framing and fastened at 200mm centres. Alternatively the sheet end butt joints may be back blocked. Plywood sheets must be fixed vertically with edges supported by framing or blocking. Sheets shall be touch fitted.

### Fixing of Plasterboard Linings

**Fasteners:** (Corners and Perimeters of the bracing element)

32mm x 6g High thread Drywall screws (Fortress® or Grabber® or Senco®)

**Fastening Centres:** (Corners and Perimeters of the bracing element)

Refer to the bracing corner pattern above. Place fasteners at 150mm centres around perimeter of bracing element. Place all fasteners 12mm from paper bound sheet edges and 18mm from sheet ends or cut edges.

### Fasteners and Fastening Centres in the Field of the bracing element

For vertically fixed sheets place fasteners at 300mm centres to the intermediate sheet joints. For horizontally fixed sheets place fasteners at the sheet edge that crosses the studs. Place daubs of Drywall adhesives at 300mm centres to intermediate studs. Take extra care to ensure that screws or nails are not placed closer than 200mm from any daubs of adhesive.

### Fixing Of Plywood Linings Fasteners: (Corners And Perimeters Of The Bracing Element

50 x 2.8mm Flat head Galvanized or Stainless Steel Nails. Fix at 150mm centres around perimeter of the bracing element and the perimeter of each sheet. Fix at 300mm centres to intermediate studs that are not at the end of a bracing element. The corner pattern fastening is conventional and there is no need for the specialized corner pattern as is required on the plasterboard side of the brace.

### JOINTING:

All fasteners stopped and all sheet joints reinforced with paper jointing tape.



Notes

---

---

---

---

---

---

---

---

---

---

---

---

---

---

---

---

---

---

---

---

---

---

---

---



### External and Internal Corners

#### Three Coat Application

##### First Coat

- Using a broad knife, evenly fill the joint recess formed by the tapered edges of the plasterboard with a suitable bedding compound.
  - Centre the paper tape along the joint. Using a broad knife, press the tape down into the compound with enough pressure to ensure that there are no air bubbles sandwiched beneath the tape.
  - Leave sufficient compound under the tape to achieve a good bond.
  - Immediately apply a thin skim coat of compound to reduce the possibility of the tape edge curling or wrinkling which can lead to edge cracking.
  - Cover all fastener heads with compound using a 100mm broad knife.
- Note – Allow compounds to harden and dry before overcoating.

##### Second Coat

- When the first coat has hardened and dried apply a second coat of compound with a broad knife. This coat should be feathered approximately 50mm beyond the edges of the first coat.
- Cover all fastener heads with a second coat of compound overlapping the first coat by approximately 25mm.
- Allow to harden and dry.

##### Finishing Coat

- When the second coat has hardened and dried, scrape back any build-up of compound along the joint to give a smooth and level surface.
- Apply a coat of finishing compound with a trowel or broad knife. Joint edges should be feathered at least 50mm beyond the edges of the previous coat.
- Apply a finishing coat to all fastener heads and overlap the second coat by approximately 25mm.
- Allow to dry and harden, then sand lightly in the same direction as the joint using 220 grit sandpaper. Care must be taken not to scuff the face paper.

##### Butt Joints

Butt or end joints that have been back-blocked should be flush stopped and finished as described for recessed edge plasterboard jointing procedures.

However, in order to give a flatter finish and minimise any apparent surface build-up of compound, each finishing coat is considerably widened so that the finished joint is approximately 500mm to 550mm wide.

- Wet sponging the edges of the finished joints after trowelling reduces sanding.
- All compounds should be applied in accordance with the compound manufacturer's instructions.
- For best results allow 24 hours between coats.

Note- When jointing during dry conditions, it is not recommended to use a chemical set compound with a long setting time as most of the moisture in the plaster may be evaporated before the actual setting time. This can result in weak joints and cause cracking.



## JOINTING AND FINISHING

### External and Internal Corners

All external corners should be reinforced with Angle/Corner beads.

#### External Corners

- Angle/corner beads must be fixed plumb and straight. Fasten temporarily at each end, ensuring the angle is straight and fasten working down from the top.
- Fix the angle bead/corner on both sides top and bottom, then fasten working down from the top nailing at 100mm centres on alternative sides. (Alternatively, tape trims may be used which eliminate the need for fasteners as they are able to be fixed using jointing compounds.)
- To finish, apply the first coat of bedding compound to both sides of the angle bead using a 200mm trowel. Allow to harden and dry, then lightly scrape back.
- Apply a second coat using a 280mm trowel. Allow to harden and dry, then lightly sand back.
- Apply the final coat of finishing compound, allow to harden and dry, then lightly sand back.

#### Internal Corners

- Apply bedding compound to both sides of the corner to be filled using a 50mm chamfered broad knife.
- Fold the paper tape along its centre line and bed into the compound using a 50mm corner tool. Allow to harden and dry.
- Apply finishing compound ensuring edges are feathered using a 100mm corner tool.
- Allow to harden and dry, then lightly sand back.
- For a superior finish take care not to deform leading edge of Angle/Corner bead during installation.

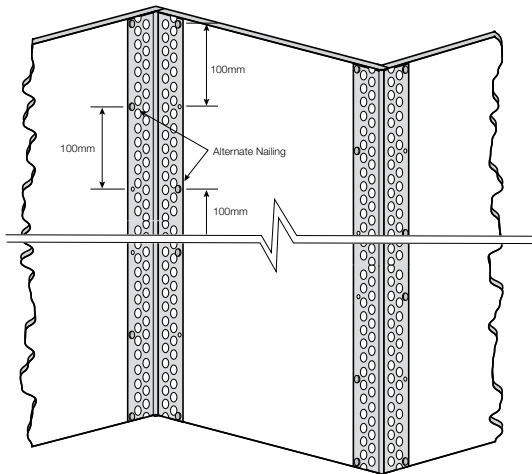



## JOINTING AND FINISHING

### Control Joints

Control joints should be provided where there is a potential stress build up from structural movement and changes in temperature and humidity. Control joints should be generally sited as follows –

In long unbroken partition or wall runs, control joints should be inserted at not more than 9 metre centres.

Door frames extending from floor to ceiling constitute an effective control joint.

Extensive interior ceiling areas should have control joints, spaced at not more than 9 metre centres in either direction without perimeter relief, or 12 metres with perimeter relief and may be positioned to intersect lighting fixtures, heating vents or air diffusers.

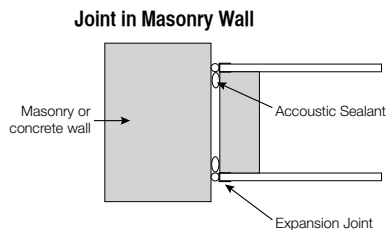
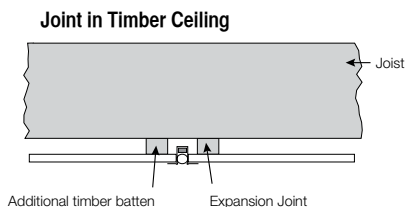
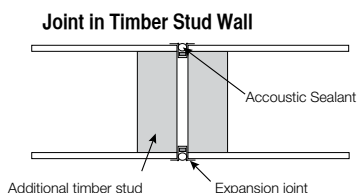



### Decoration

#### General

Elephant Plasterboard surfaces provide an excellent base for painting, wallpapering and other decorative finishes when installed to the requirements of the Australian and New Zealand Standard 'The Application and Finishing of Gypsum Linings in Residential & Light Construction' and the instructions outlined in this publication.

The use of satin and high gloss paints can at times highlight surface imperfections. When these paint finishes are required it is important that an even texture is achieved over the entire plasterboard surface. No building material has an absolutely flat surface, and all that can be achieved in practice is the appearance of flatness. It is known that surfaces that appear flat in diffuse light may appear rough and uneven when lit by light falling nearly parallel to the surface.

When preparing surfaces and applying decorative finishes, it is important that all materials be used strictly in accordance with the manufacturer's instructions.

#### Surface Preparation

Before sealer is applied remove all loose dirt and dust with a soft brush or dry cloth. Ensure that all joints are dried thoroughly before sealer or paint is applied. Surface imperfections should be made good with an approved filler.

#### Sealers and Primers

When applying sealers and primers, apply sufficient quantities to ensure that the surface is completely covered. Do not overwork or over roll the first coat as this may cause the paint to lift over the jointed areas.

Brush or roller application of sealers is recommended to obtain the best results as this ensures adequate binding over the jointed areas.

Allow the first coat to dry thoroughly.

#### Top Coats

Under normal conditions, allow 12 to 18 hours after the application of sealers before applying the subsequent coats of paint. In rainy, humid or cold weather conditions a waiting period of up to 36 to 48 hours may be required before re coating. For the best results apply the final coat with a roller which will ensure a full cover coat and a uniform texture over the entire surface.

- Plasterboard that has been fixed and allowed to stand for a long periods prior to painting may discolour due to exposure to light. This should be well sealed with an approved oil based sealer before the application of the finishing coats of paint.
- Oil or solvent based paints are recommended in areas of high humidity, or where water resistance and 'cleanability' are important, such as bathrooms, kitchens, laundries and toilets.



### Accidental Damage

#### 1. Fire

After an outbreak of fire the paper face, core and joints must be checked and where the paper face or the core of any sheet has been affected then the whole sheet must be removed and replaced.

#### 2. Bracing

After a severe earthquake and extreme wind conditions, the Bracing elements must be checked for cracks at joints, deformation of sheet or joints and damage to the fixing/sheet sealing.

Where the damage is minor, for example, limited nail pops or joint cracks, the item should be made good as soon as practicable. Where the damage is severe, for example, board distortions and fixing failure, then the whole sheet must be re-nailed or replaced and advice sought from a consultant engineer.

#### 3. Flooding

After a flood or when severe moisture ingress has occurred, all Elephant Plasterboard Systems should be inspected by a suitably qualified person. Certain components of the system may need to be replaced and in this instance we recommend that advice is sought from the manufacturer's agent.

#### 4. Direct Impact

If the integrity of the Elephant Plasterboard Drywall System is affected then the area up to the nearest stud or nog must be cut out and made good with new Elephant Plasterboard, including jointing.



Notes

---

---

---

---

---

---

---

---

---

---

---

---

---

---

---

---

---





## Contact Details

### Customer Services

New Zealand

Freephone 0800 ELEPHANT (353742)

Telephone +64-9-818 7706

Facsimile +64-9-818 7702

### Bracing, Fire and Acoustic Ratings

Elephant Plasterboard Bracing, Fire and Acoustic Ratings have been obtained by independent testing and opinions sourced from organisations with accredited quality assurance.



Exceeds the New Zealand and Australian Standard. AS/NZ 2588

Manufactured to ISO 9001 International Organisation for Standardisation

# **Elephant Plasterboard**

## **Installation Guide**

August 2015

**Elephant Plasterboard (NZ) Limited**

---

FOR MORE INFORMATION VISIT

---

**[www.elephantplasterboard.co.nz](http://www.elephantplasterboard.co.nz)**

**email [info@elephantpb.co.nz](mailto:info@elephantpb.co.nz)**

**call 0800 ELEPHANT (353 742)**



**Elephant**  
**Plasterboard**

**STRENGTH WITH STYLE**