

# VISTELLE<sup>®</sup>

## STYLED BY YOU

### Vistelle<sup>®</sup> Installation Guide



**Edition 2**

NEW ZEALAND  
TOLL FREE NUMBER 0800 33 36 39



# Introduction

**Vistelle®** is the superior DIY high gloss acrylic panel especially suited for kitchen splashbacks, barbacks and many other decorative applications in residential or commercial environments.

Vistelle is completely inert. It will not release any emissions to the environment. The non-stick outer surface does not harbour mould or calcium build-up. The material is ultra hygienic and does not promote bacterial growth or transmission.

## ⚠ Warnings

- Vistelle is not to be used in direct contact with any heat source above 70 deg C.
- Vistelle panels are not suitable as a wall finish behind gas cooktops. They can be used as a splashback behind electric and induction cooktops with a minimum clearance of 50mm between rear edge of cook top and the face of the Vistelle panel.
- Horizontal spread of adhesive is necessary to ensure the section behind the cooktop is firmly secured to the wall.

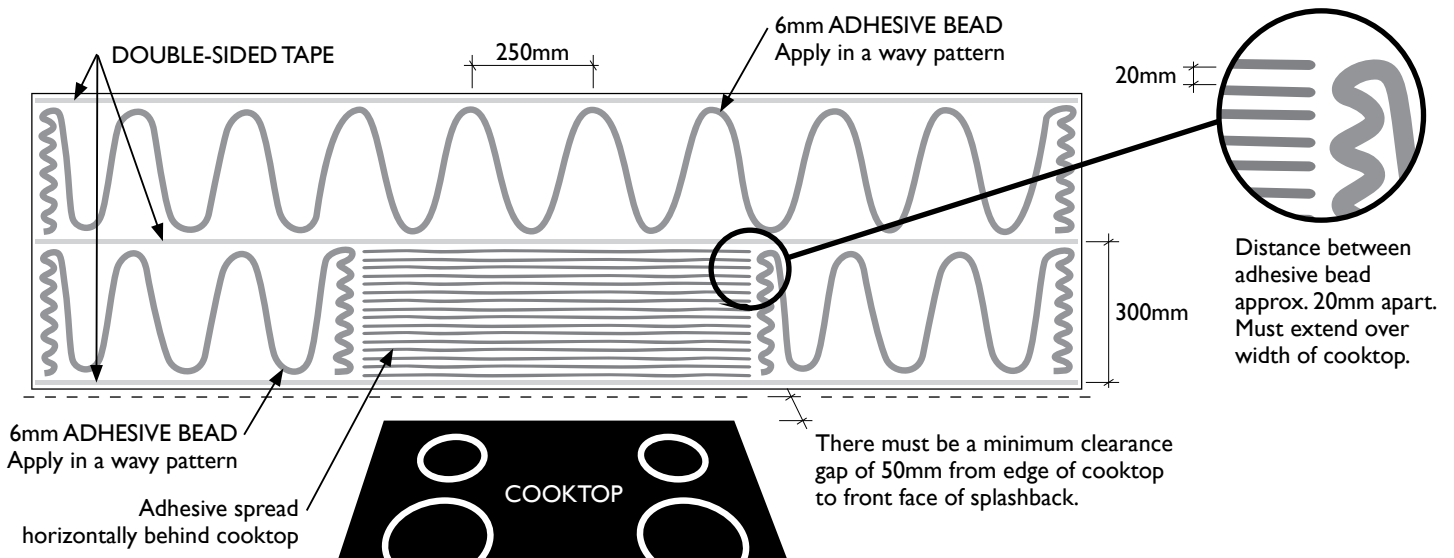

- Vistelle will expand and contract with temperature at the rate of 0.7 mm / 1000 mm / 10 deg C so it's very important to allow expansion gaps at the perimeter of each panel. Expansion gaps of 4mm are recommended.
- When using Vistelle for renovation over existing tiles or other wall finish, it may be necessary to reposition the taps and outlets to align with the finished surface of the Vistelle panel
- Do not store or transport Vistelle panel outdoors or in direct sunlight or in extreme heat
- Panels must be stored inside, and stacked horizontally to avoid any bowing of the panel
- Vistelle may have sharp edges, so always wear gloves and other appropriate clothing and footwear for your protection during the installation process
- Avoid direct contact by hot cookware or utensils, or the face of the panel may be damaged

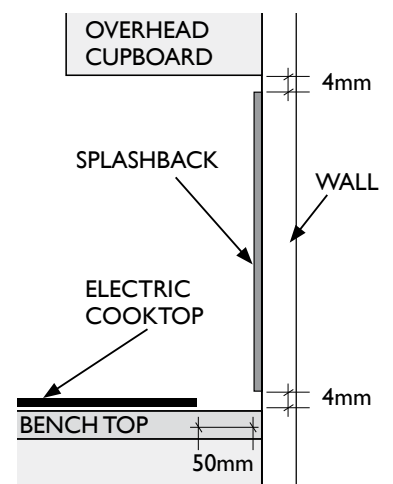

⚠ Ensure the substrate you are installing this product to conforms to local Building Regulations. This product and the install methods are designed for vertical applications. Overhead applications may be used only with an Enginner Certified Mechanical Fix system.

# Tools and materials

Some or all of the following tools may be required depending on the scope of the installation.

## MEASURING

- Measuring tape
- Soft pencil or felt tipped marker pen
- Carpenters square

## CUTTING

- Circular saw (minimum 60 tooth blade)
- Power or battery drill and slightly blunt twist drills and/ or step drills
- Medium and fine grit sandpaper and sanding block or power planer
- Personal eye, hearing, hands, and footwear protective equipment

## INSTALLATION

- Silicone caulking gun
- 12mm x 1.6mm thick double coated polyethylene foam tape with synthetic rubber adhesive, mirror mounting or 3M wide tape is suitable
- Selley's Liquid Nails - Glass and mirror neutral cure silicone
- Soft flexible plastic spatula

## Area Preparation

- Ensure the walls are smooth, clean and dry
- All substrate wall panel fixings must be set flush or recessed
- Seal MDF or plasterboard with acrylic primer and allow to dry

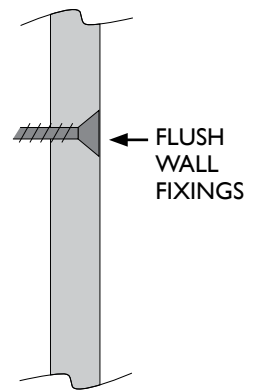

## Tiled Walls

- Vistelle panels can be easily installed over existing tiled walls as long as the tiles are securely attached and thoroughly cleaned before installation.
- Ensure the tiles are free of build up by cleaning and scrubbing with recognised cleaning product. Conduct a final clean using with a degreaser such as "Sugar Soap", rinse well with and allow to dry.
- Check the walls carefully for high spots and remove any tiles or fittings that may interfere with Vistelle panel or may create a wavy result when panel is installed.
- Exposed edges can be sealed with silicone. A finishing trim can also be used to create a neat appearance covering both the tile and Vistelle panel edge.

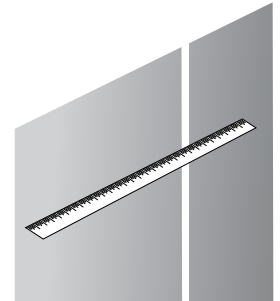

SUBSTRATE PANELS TRUE AT JOINTS

## Mechanical Fixing

- Mechanical fixing may be used for Vistelle. When using mechanical fix methods ensure that fixings are a maximum 700mm from centres - *adequate allowance must be made for Thermal Expansion at each Fixing point*

## Measuring

- Measure each wall area and decide on suitable panel size
- Avoid large cut outs for windows or other features and use panel joins for these areas instead
- For large panels allow for 4 mm joints at each corner and between panels
- Check that the installation area is square. If the area is not square or an odd shape, we recommend fabrication of a template and trial fitting. Use the template to cut the Vistelle sheet to achieve a good result.

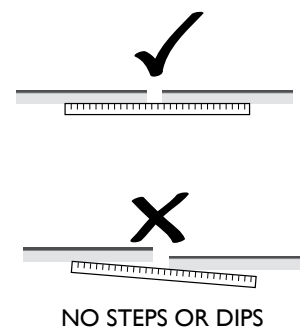

## Marking Out

- Vistelle is supplied with a protective film on both sides of the sheet. Do not remove either at this stage
- Mark all holes and cut lines on the film using a felt tip pen, do not use metal scribes
- Do not mark out the sheet in direct sunlight or very cold conditions as thermal expansion/contraction could affect final panel size prior to installation
- Do not remove the protective film on the front of the panel until after the installation
- Take care when storing panels on the edge. Use protective medium to avoid damage

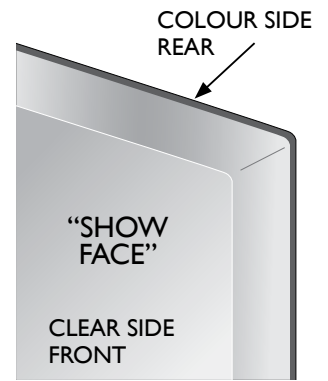

## Cutting

- When cutting or drilling Vistelle, always wear appropriate personal protection equipment
- Appropriate clamping and support is essential to avoid vibration and potential chipping of the edge. Always protect the panel using a soft material between the clamp and the sheet surface
- Using a circular saw will deliver a straight and accurate cut. Best results will be achieved by cutting through the Vistelle and into the sacrificial support timber board
- Use a fine cut blade that is suitable for plastic or aluminium cutting (recommended)
- Sharp blades should always be used to avoid chipping or burning the Vistelle
- Do not allow the blade to overheat, work at a moderate speed and pressure
- To reduce the risk of chipping, when using a portable circular saw, cut with the colour side of the Vistelle sheet facing UPWARDS. If using a fixed table circular saw, cut with the colour side of the Vistelle sheet facing DOWNWARDS

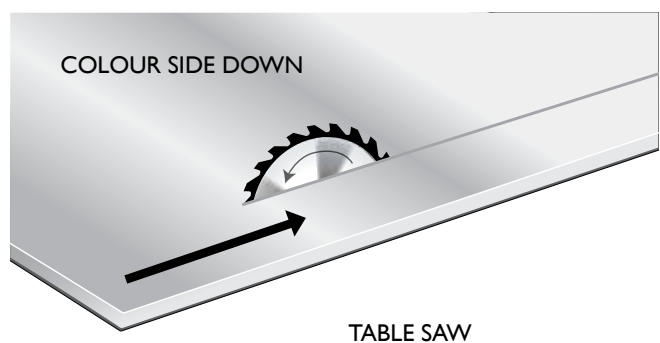
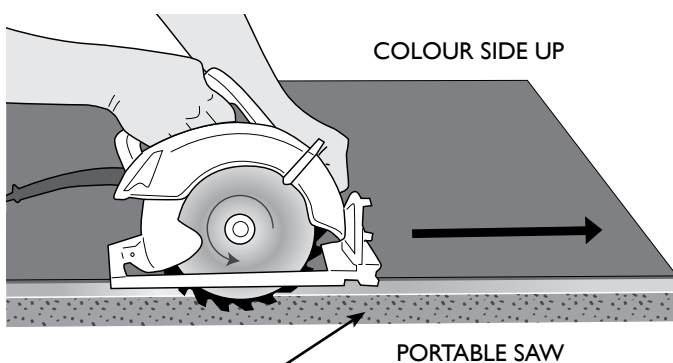
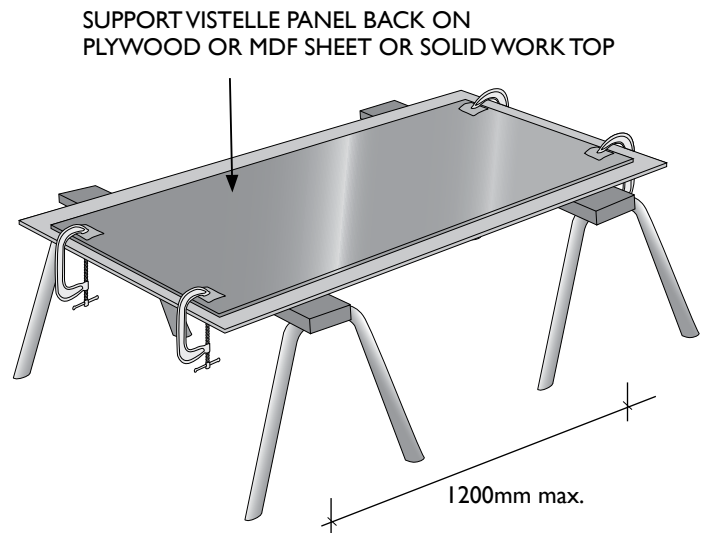

- Jigsaws can be used for cutting short distances such as power point openings. You must only use Jigsaw blades that are suitable for aluminium or plastics. Cut with the colour side of the Vistelle sheet facing UPWARDS with a jigsaw
- Do not use Jigsaws to make long cuts. The blade may overheat and melt the sheet at the edge resulting in a poor finish
- Clean swarf away frequently after cutting to avoid damage to the protective film

# Drilling and Openings

- Drilled holes should be no closer than 10mm to the edge of the panel sheet
- Do not create long openings close to the edge of the sheet, as the sheet will be difficult to handle during the install
- Always drill a hole at the corner of any cut-out or notch. Avoid cutting square inside corners
- Slightly blunt drill bits work better as they cut through the material more slowly. To blunt the drill bit, rub the cutting edges with 120 grit emery paper
- Drill from the face side (clear side) of the Vistelle sheet to reduce the risk of chipping. Best results will be achieved with a slow to medium drill speed, use only light pressure
- Fine toothed hole saws can be used for larger holes. Start from the **clear side** and then from the **colour side** to achieve the best finish
- Step drills are ideal for mid size holes and also making smaller holes into larger ones
- When attaching screws or other fittings, drill a hole with a minimum of 1mm clearance between the fixing and the Vistelle panel. Fix into the substrate and structure behind. **DO NOT SCREW INTO THE VISTELLE PANEL**

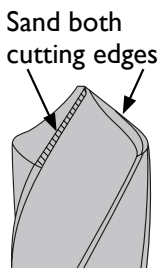

**DRILL BIT**

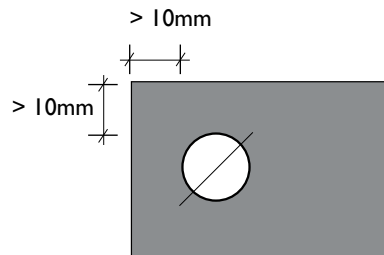

**HOLES**

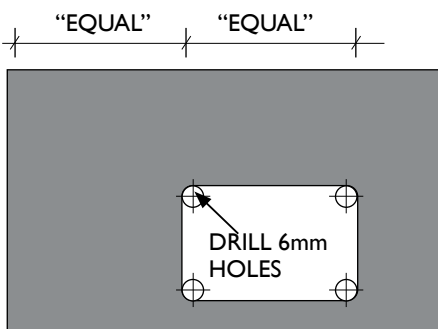
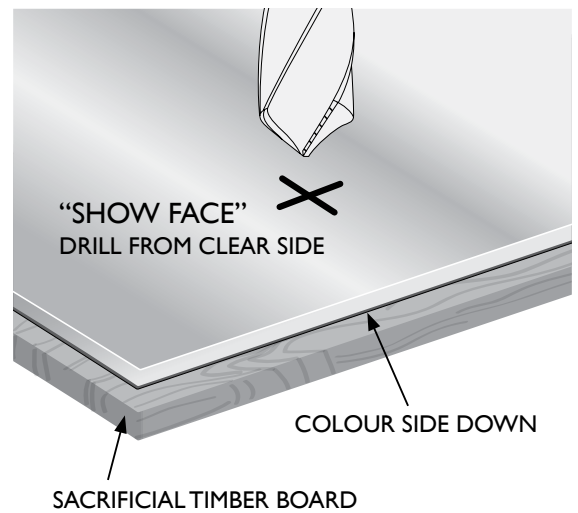

**OPENINGS**

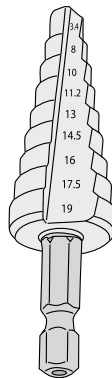

**STEP DRILL**

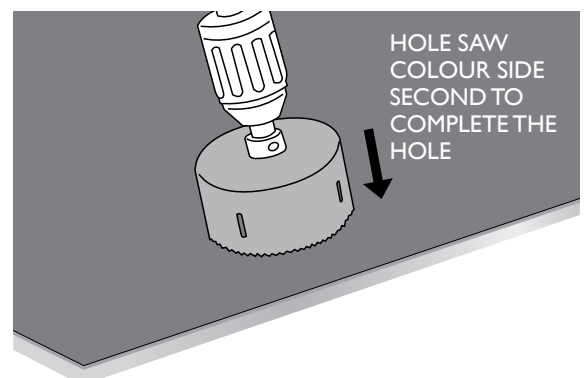
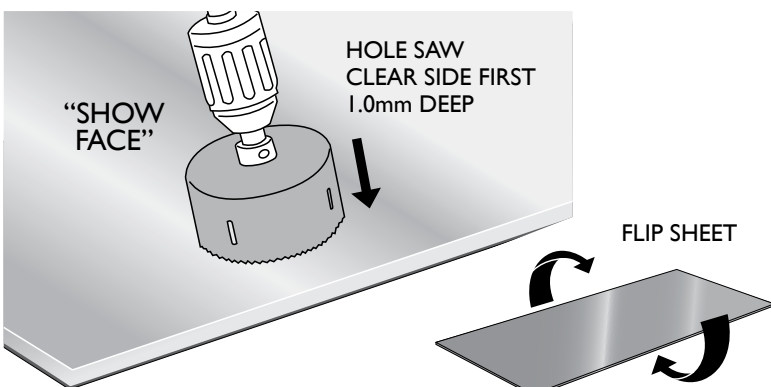

# Edge Finishing

- All Sawn edges must be sanded or planed prior to installation of Vistelle panels
- Edges can be sanded using medium (120 grit) and then 180 grit, finishing with fine (240 grit) emery paper. Use a sanding block to give a smooth flat edge finish. To give edges a glass like appearance, finish with fine metal polish like Autosol or Brasso and a microfibre cloth.
- *Alternatively* a single pass with an electric planer will provide a smooth edge and neat appearance



**NOTE** - Do not use flexible PVC edge trimming or gaskets at any time as they contain chemical agents that could damage the sheet.

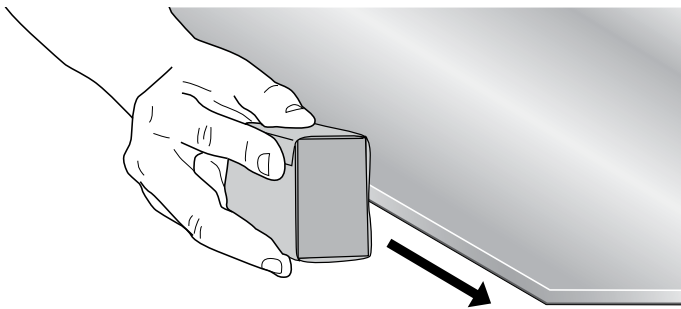

BLOCK SANDING

STEP 1: MEDIUM 120 GRIT  
STEP 2: FINE 240 GRIT

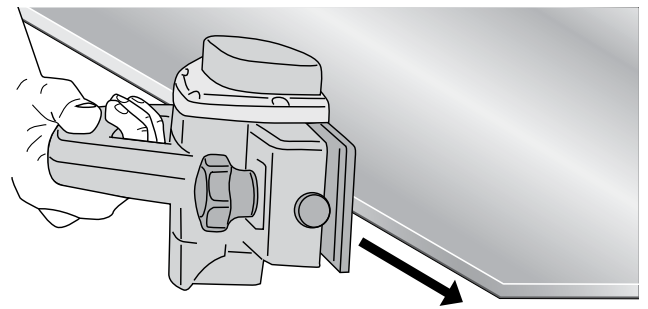

ELECTRIC PLANER

# Panel Installation

- Remove the protective film from rear surface (the colour side). **DO NOT** remove the protective film on the front (clear side) of the panel at this time
- Scuff the rear surface with coarse scouring pad or 120 grit emery paper
- Remove sanding dust with clean cloth or tack rag

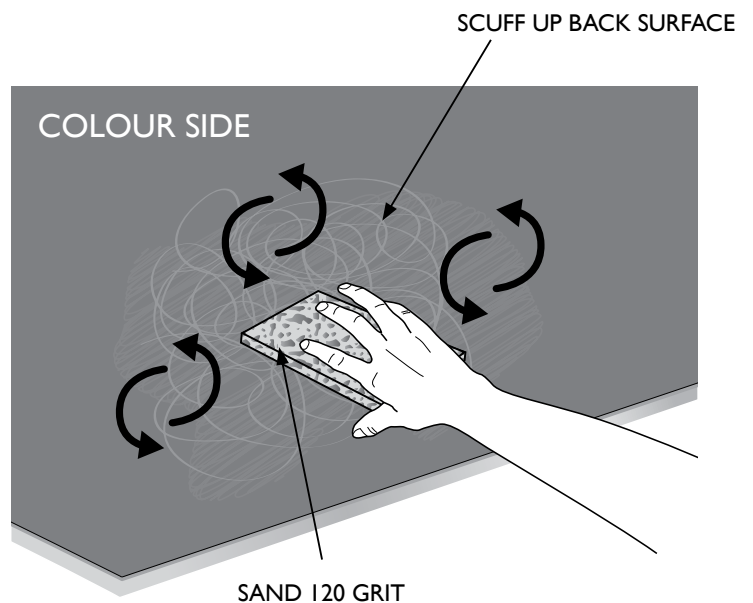

# Panel Installation

- STEP 1** Ensure the rear surface is clean and free of dust or any other substance before applying the tape and silicone adhesive
- STEP 2** Apply 18mm x 1.6mm thick double-coated polyethylene foam tape with synthetic rubber adhesive on the rear surface of each Vistelle panel, along the long sides at approximately 300mm spacing. Use a roller to firmly secure the tape to the panel. Note: The silicone and tape are applied to the **COLOUR SIDE**. The clear side “show face” must face outwards
- STEP 3** Trial fit each panel with tape applied to ensure trim size and expansion gaps are correct

## FOR LARGE PANELS

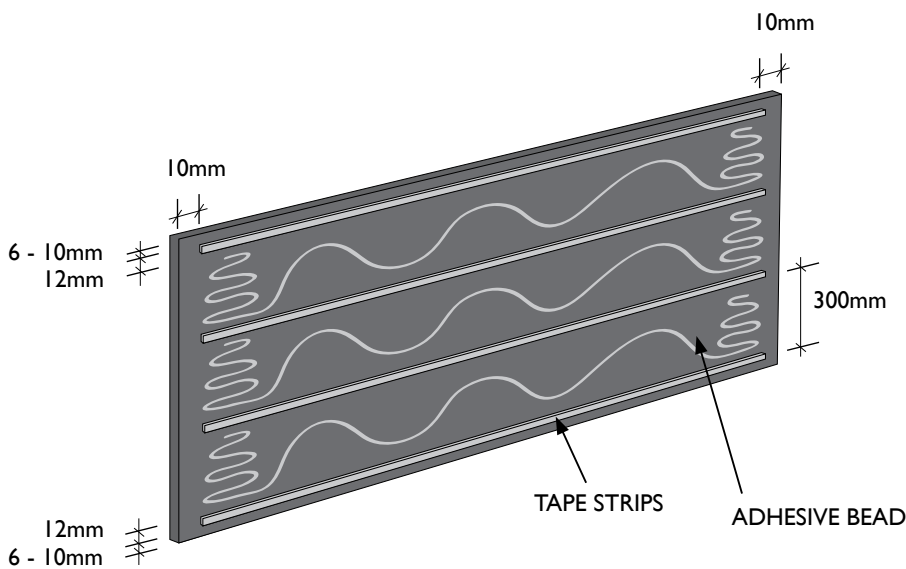

## FOR HOLES AND OPENINGS

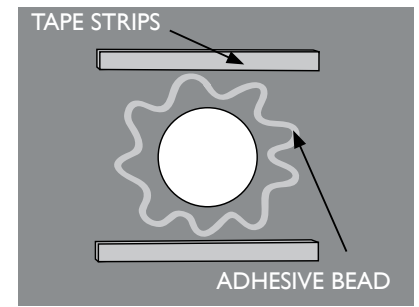

REVERSE SIDE

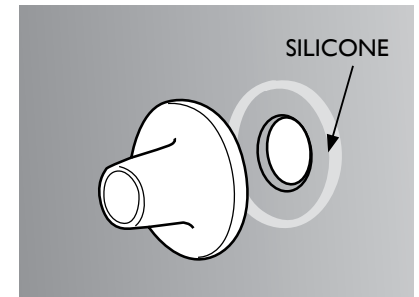

FRONT SIDE

- STEP 4** Apply a 6 mm bead of translucent neutral cure silicone in a wavy pattern between each tape strip. Near the edges of the panel, increase the wavy pattern as show in the figure. Run a bead of silicone on the rear of the panel around any holes or cut outs. Always use a neutral cure silicone
- STEP 5** Remove tape liner
- STEP 6** Install the panel by resting on removable spacers at the bottom and between panels
- STEP 7** Firmly rub down panel to ensure tape bonds and adhesive contacts the wall. Allow to cure for 72 hours
- STEP 8** Remove the spacers and seal the joints with neutral cure wet area silicone. If the outer protective film of the panel is damaged or not adhered well, peel approximately 40mm of the protective film from panel edges and carefully apply 20mm masking tape either side of the joint. Once gap is filled, remove excess silicone using a soft flexible plastic spatula

**NOTE:** To achieve a smooth finish on the silicone, mix up a 10% solution of mild dish washing liquid and water. Spray the solution over the silicone bead before wiping off with the spatula



Do not use Acetic cure silicone

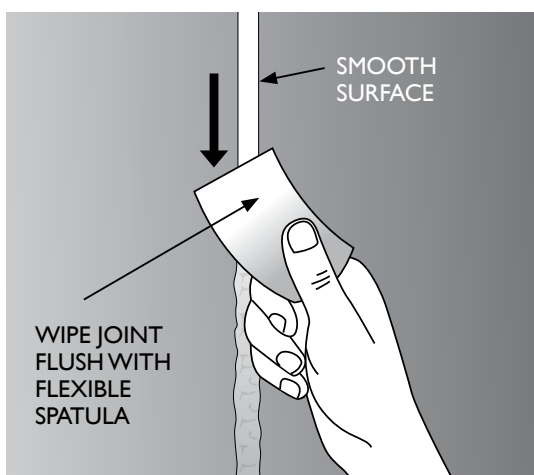

Do not use Acrylic sealant as it will not bond to the panels

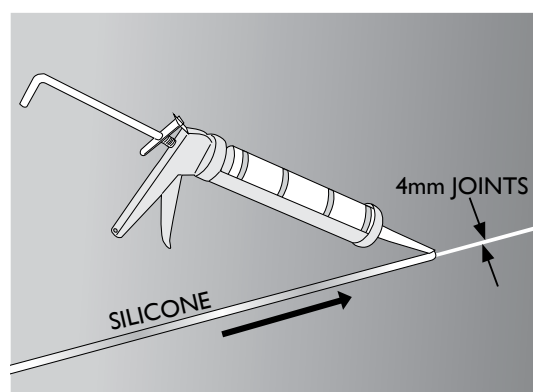

- Immediately after the silicone is applied, carefully remove the outer protective film or masking tape in one continuous movement to achieve the best finish

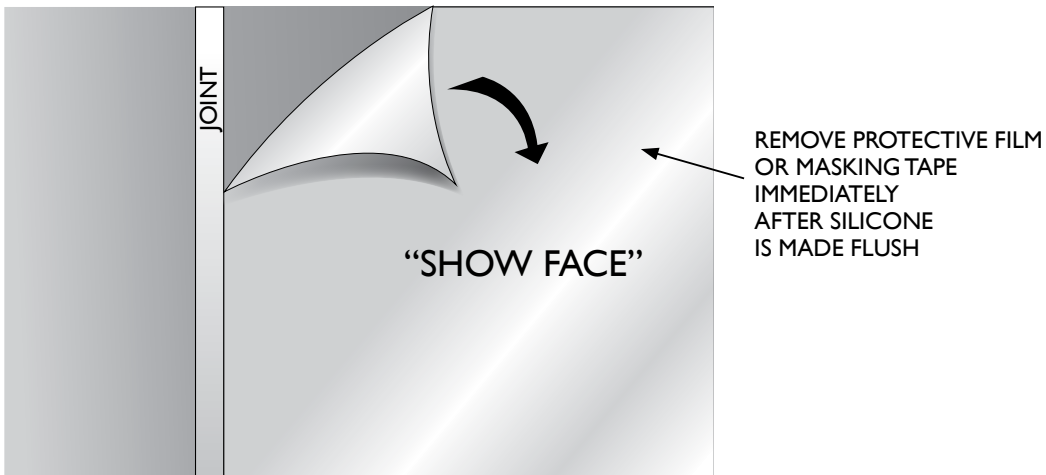

## Cleaning

Best results are achieved using a soft microfibre cloth or chamois with non-abrasive detergent in warm water. Grease or oil can be removed with Kerosene and a microfibre cloth. Always rinse off with clean water.



Do not rub the Vistelle surface when it is dry.



Do not use brushes or scouring pads on the Vistelle as prolonged use may damage the high gloss surface.

Do not use cleaners with high alkali content.

Mineral Turpentine on a soft cloth can be used to clean off excess silicone after install if necessary.



# Technical Table

GENERAL PROPERTIES	RELEVANT STANDARD	KITCHEN SPLASHBACK
Water Absorption	ASTM D-570	< 0.5%
Gloss	AS/NZS 1580.602	> 80% 4H
Pencil Hardness	ASTM D-3363	
Thermal Expansion & Contraction		0.7mm/1000mm/10 °C
HDT, 264psi, 1.82MPa	ASTM D-648	96 °C
CTE, -30 to 30C	ASTM D-696	7 mm/(mm.°C)x10 <sup>-5</sup>
Continuous Service Temperature		77 °C
Fire Behaviour - Australia BCA 2006	AS/NZS 13837:1998	Rating 4

## 10 Year Limited Warranty

Vistelle panels are warranted for faulty materials and workmanship for a period of 10 years, with 10% reducing value per year after the first 3 years. The warranty is void if incorrect installation or cleaning procedures have been used. The warranty does not include fabrication, installation, trade services or other consequential costs.

The responsibility for the removal and installation of a replacement product is with the owner and/or installer of where the manufacturer accepts that the product is completely at fault, a maximum contribution of \$200.00 (NZD) towards the removal and installation will be made.

For more information visit [www.vistelle.com](http://www.vistelle.com)

© Copyright / Patent Pending

Oakmoore Pty Ltd, ABN: 13 056 159 570

1. Oakmoore expressly disclaims any representations or warranties of any kind, whether express or implied, as to the accuracy, currency, completeness and/or the merchantability or fitness for a particular purpose of any information contained in or provided via this documentation and/or any service or product described or promoted in this document. 2. It is the customer's responsibility to thoroughly examine Vistelle by a qualified person, to determine whether it is suitable for the application it was purchased for. 3. The receiver of our products is fully responsible to check and to take into account possible third party's patent rights, as well as the existing laws in the country of installation prior to installing our product. 4. No liability may be derived from these images or statements nor from our free technical advice. 5. Printed images are to be used as a guide only.

**VISTELLE**<sup>®</sup>  
STYLED BY YOU

[vistelle.com](http://vistelle.com)