



Quality - Built In

ASSEMBLY INSTRUCTIONS



MK2

BASE SIZE 2545mm x 1715mm

ASSEMBLY INSTRUCTIONS

Tools Required:

- Drill
- Drill Bit 3.5mm
- Drill Bit 6mm (for clear roof panel only)
- Riveter
- Hammer
- Nail Punch
- Tape Measure
- Ladder or Saw stool
- Spanners x 2
- String Line
- Tin Snips
- Skillsaw and Jigsaw (for floor only)
- Masonry Drill and 10mm Masonry Bit (for Bolt Down Kit only)

Before you start:

- Read all instructions carefully.
- Identify all parts and check quantities against checklist.
- If you are making your own floor refer to Raised Base Plate section now.

Safety:

- Do not attempt to build your shed in high winds.
- Beware of sharp edges.
- Protect your eyes and ears.
- Use electric tools with care. Use a Safety Trip Switch.
- It is easier and quicker if this shed is erected by two people.

Select your site:

- Your shed must be level. Achieve this by either levelling the ground or by using blocks.
- If your shed is to be positioned on wet or damp ground, we recommend that your shed is raised up off the ground slightly.

KIWI MK2 PARTS LIST

 ROOF COLOUR

 WALL COLOUR

 INVOICE NO:

BASE SIZE: 2.545 X 1.715

STANDARD SHED KITSET

QTY	LENGTH	DESCRIPTION	PACKED	CHECKED
4	2.090m	Gable End Wall Sheets	<input type="checkbox"/>	<input type="checkbox"/>
5	1.890m	Wall Sheets	<input type="checkbox"/>	<input type="checkbox"/>
1		Door - Standard <input type="checkbox"/> Security <input type="checkbox"/>	<input type="checkbox"/>	<input type="checkbox"/>
1		Instruction Booklet	<input type="checkbox"/>	<input type="checkbox"/>
2	0.200m	Jack Studs - 90 x 45mm	<input type="checkbox"/>	<input type="checkbox"/>
1		Hardware Pack	<input type="checkbox"/>	<input type="checkbox"/>
		Touch-up Paint & Brush	<input type="checkbox"/>	<input type="checkbox"/>
3	2.000m	Roof Sheets	<input type="checkbox"/>	<input type="checkbox"/>

OPTIONAL EXTRAS

QTY	LENGTH	DESCRIPTION	PACKED	CHECKED
106	50mm	Flooring Nails	<input type="checkbox"/>	<input type="checkbox"/>
6	75mm	Flooring Nails	<input type="checkbox"/>	<input type="checkbox"/>
WINDOWS				
		Fixed Window Frame	<input type="checkbox"/>	<input type="checkbox"/>
	0.580m	Glaze Beads	<input type="checkbox"/>	<input type="checkbox"/>
	0.603 x 0.603m	Glass	<input type="checkbox"/>	<input type="checkbox"/>
			<input type="checkbox"/>	<input type="checkbox"/>
		Louvre Window Frame	<input type="checkbox"/>	<input type="checkbox"/>
	0.588 x 0.150m	Glass	<input type="checkbox"/>	<input type="checkbox"/>
	0.710 x 0.240m	Over Panel - For Gable ends only	<input type="checkbox"/>	<input type="checkbox"/>
1		Window Hardware Pack	<input type="checkbox"/>	<input type="checkbox"/>
CLEAR ROOF PANEL				
	2.000m	Roof Sheets	<input type="checkbox"/>	<input type="checkbox"/>
	0.975m	Flat Roof Sheet	<input type="checkbox"/>	<input type="checkbox"/>
	0.975m	Clear Roof Panel	<input type="checkbox"/>	<input type="checkbox"/>
	0.350m	Pressed Capping Sheet	<input type="checkbox"/>	<input type="checkbox"/>
	0.900m	Bevel Edge Support 45 x 45mm	<input type="checkbox"/>	<input type="checkbox"/>
1		Clear Roof Hardware Pack	<input type="checkbox"/>	<input type="checkbox"/>
SECURITY PARTS				
		Security Single Door Hardware Pack	<input type="checkbox"/>	<input type="checkbox"/>
		Alarm - MA20	<input type="checkbox"/>	<input type="checkbox"/>
		Shed light	<input type="checkbox"/>	<input type="checkbox"/>
			<input type="checkbox"/>	<input type="checkbox"/>
		Bolt Down Kit	<input type="checkbox"/>	<input type="checkbox"/>
		Peg Down Kit	<input type="checkbox"/>	<input type="checkbox"/>

DATE: / /

PACKED BY:

CHECKED BY:

Total Weight

kg

MK2 TIMBER FRAME

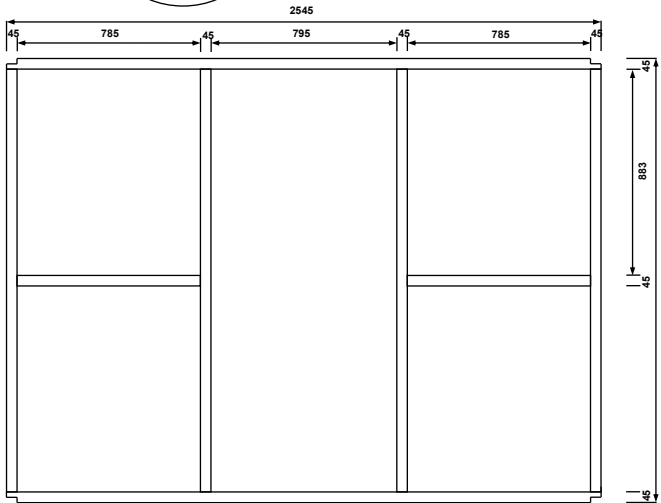
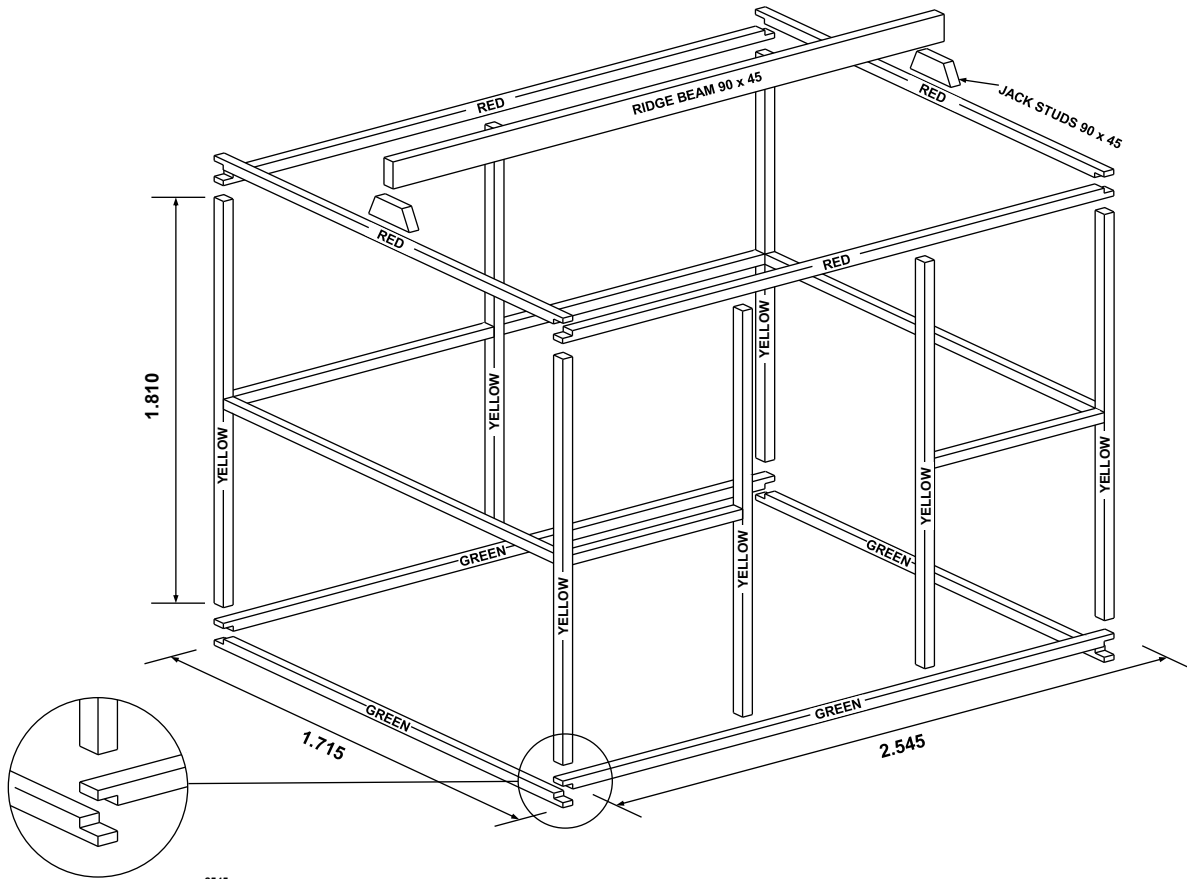

FRONT WALL

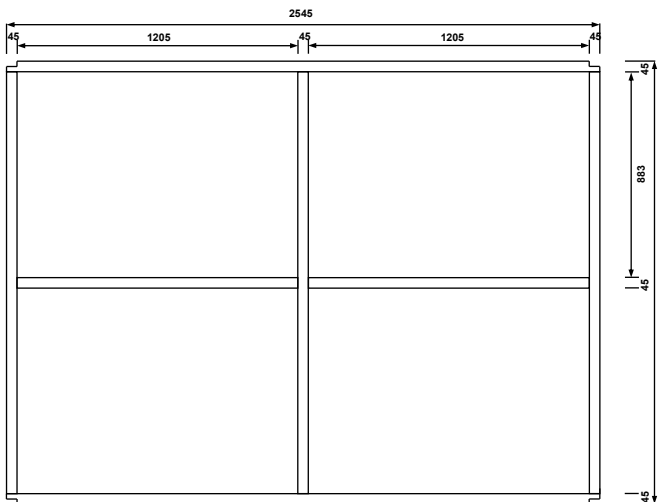

BACK WALL

1900
(or 1870 for Raised Base Plate only)

1900
(or 1870 for Raised Base Plate only)



MK2 TIMBER FRAME

Note: If fitting a window in the Back Wall, there will be no centre stud on that side. Instead nail in a full length Nog (2.455) using Window Studs (.883) to get correct height. Position one Window Stud centrally beneath the Nog and nail in place. Further window studs and Nogs are fitted after the cladding is on.

Step 1: Back Wall: Select one 2.545m Base Plate (Green), one 2.545m Top Plate (Red) and three Studs (Yellow). Lay out Plates and two Studs on a flat surface and nail together using two 75mm nails per joint. Nail in remaining centre stud using 1.205m Nogs to get correct position. Position Nogs .883m down from Top Plate and nail in place.

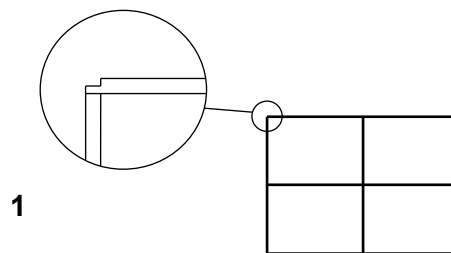

Step 2: Front Wall: Select one 2.545m Base Plate (Green), one 2.545m Top Plate (Red), four Studs (Yellow) and two .785m Nogs. Nail studs to each end of Plates. Nail in remaining two studs using the .785m Nogs to get correct position. Position Nogs .883m down from Top Plate and nail in place.

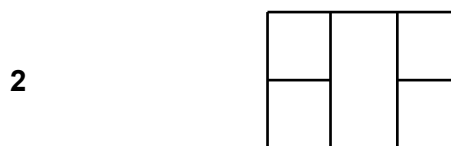

Step 3: Select two 1.715m Base Plates (Green) and two 1.715m Top Plates (Red). With front wall lying on the ground, nail Plates to frame. Ensure Green joins to Green and Red joins to Red.

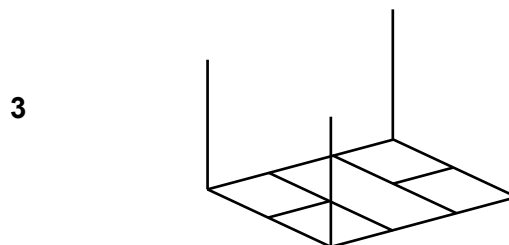

Step 4: Position the back wall frame on top of plates. While someone supports frame, nail in place.

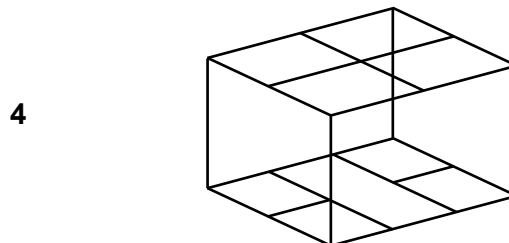

Step 5: Carefully roll frame over onto its base. (Pieces of timber from the packaging may be used to temporarily brace the frame before rolling it over). Position 1.625 End Wall Nogs .883m down from Top Plate and nail in place. If fitting a Kiwi Floor, fit Floor Joists now. Place joists equally and nail in place using three 75mm nails per end.

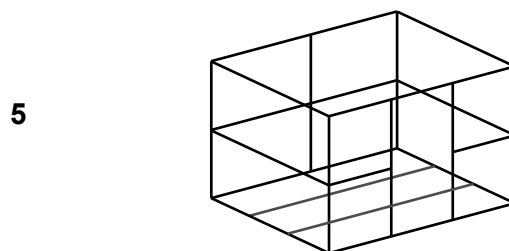

Step 6: Position a Jack Stud centrally on 1.715m End Wall Top Plates and skew nail in place with two 75mm nails per Jack Stud. Position Ridge Beam centrally on Jack Studs and skew nail in place using two 75mm nails each end. Pre-drilling holes before nailing will prevent timber from splitting.

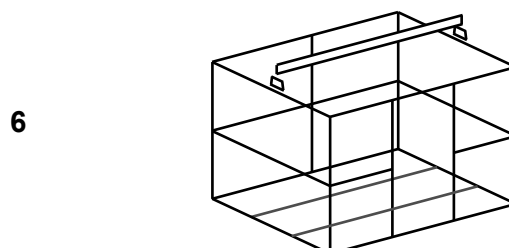

MK2 WALL CLADDING

TO AVIOD CORROSION:

- Where at all possible try not to trap metal filings between two sheets. Remove all metal filings before riveting.
- Carbon in pencils reacts with the Zinc/Aluminium coating on steel. Use either crayon or ink to mark steel.

TERMS EXPLANATION

- **To Tack:** To Tack on a wall sheet means to use minimum nails hammered partly in to hold Wall Sheets in position. Should a Wall Sheet need to be re-positioned, the nails can easily be prized out.
- If a window is required, identify Wall Sheet(s) with window hole pre-cut. Lean up Wall Sheets where window(s) are to be located.

CLADDING DETAIL Birds Eye View

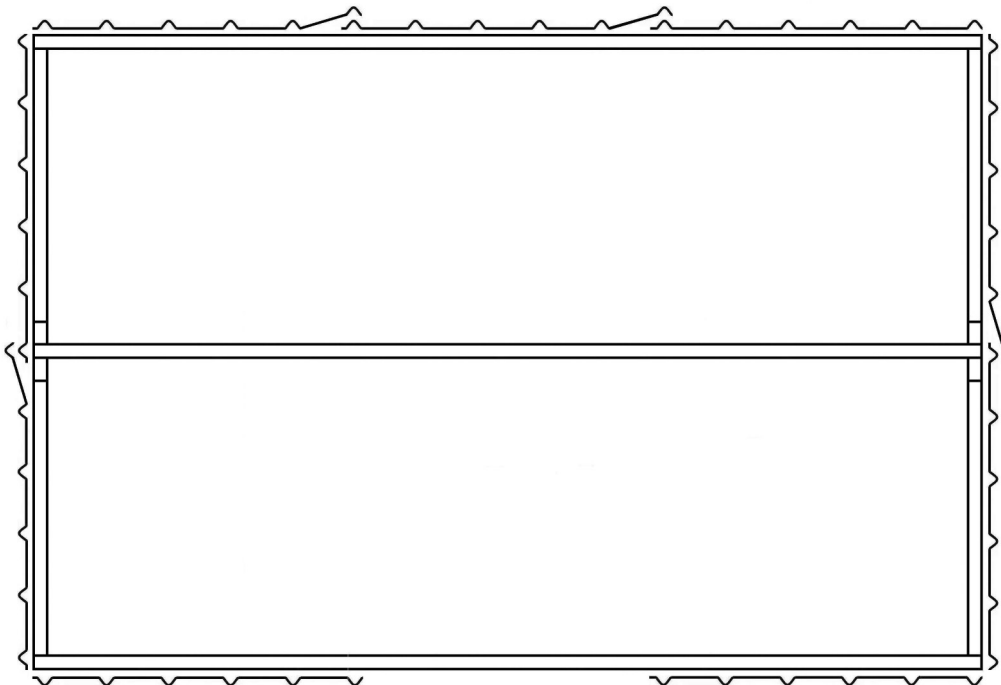

Note:

When fitting Gable End Sheets ensure they overlap correctly (*fig 1*).

The overlap direction may differ from plan.

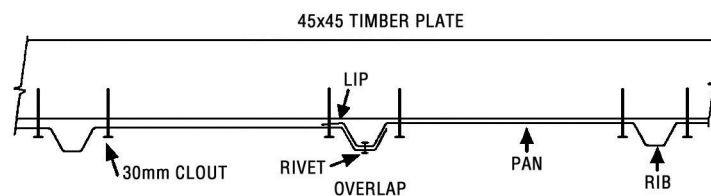

fig. 1

MK2 WALL CLADDING

Note: For sheds with the Raised Base Plate option, the Wall Sheets will protrude 20mm below the Bottom Plate. Refer to Raised Base Plate section (Page 14).

Step 1: Front Wall: Start at the left hand side. Position the Wall Sheet with the LIP on the left hand side. Ensuring the LIP is flush with side of the Stud and the top of the Top Plate, tack in place. Repeat with Wall Sheet on the right hand side of doorway.



Step 2: Back Wall: Position the first Wall Sheet with the LIP on the right hand side. Ensuring the LIP is flush with the side of the Studs and the top of the Wall Sheet is flush with the top of the Top Plate, tack in place. Position the next Wall Sheet with the LIP on the right hand side. Overlap as shown in (fig 1). Ensuring Wall Sheet is flush with top of Top Plate, tack in place. Repeat with remaining sheet.



Step 3: End Walls: Lean Gable Wall Sheets against the shed to form gable shape. With the LIP flush with side of Stud tack in place ensuring the bottom of the Wall Sheet is 10mm above the bottom of the Bottom Plate. Tack on remaining Wall Sheets. Repeat with other gable end. If fitting a window, nail in Window Studs and Nog now. Refer to Window instructions.



Step 4: Nailing Off: Nail one 30mm Clout each side of the Rib (two per Pan) into the Top Plates and Bottom Plates. Nail Wall Sheets to mid wall Nogs (one per pan). Nail each corner Wall Sheet to Studs using two 30mm Clouts evenly spaced.

Gable Ends: When nailing Gable Wall Sheets to the Top Plate, use a String Line. At the top of the gable nail two 30mm Clouts into the end of the Ridge Beam. This will stop it from twisting.

MK2 LOUVRE WINDOW (Optional)

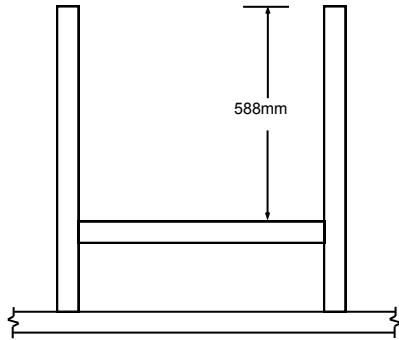

Step 1: Lay out the two window studs (883mm) and Nog (634mm) on a flat surface. Position Nog and nail in place using 2x 75mm nails at each end.



Step 2: On the inside of the shed, position studs and Nog centrally on window opening. Make sure the studs are parallel and nail into Top Plate and End Wall Nog.



Step 3: Nail wall Sheets to window framing using 30mm clouts. (return to step 4 on page 7 and complete). Then fit Window Frame). Position Window Frame centrally on window opening and rivet it to ribs. Pre-drill holes in each corner and nail Window Frame to framing, using 50mm nails.



Step 4: If the Window is in the gable end, temporarily position the Over Panel above Window Frame. Following the same angle as the gable, mark and cut to suit.



Step 5: Rivet Over Panel to the Window Frame with rivets.



Step 6: From the inside of the shed, slide Louvre Glass into Louvre Units attached to the Window Frame. Bend up tabs to keep Glass in position.

MK2 FIXED WINDOW (Optional)

Step 1: Lay out the two window studs (883mm) and Nog (590mm) on a flat surface. Position Nog and nail in place using two 75mm nails at each end.

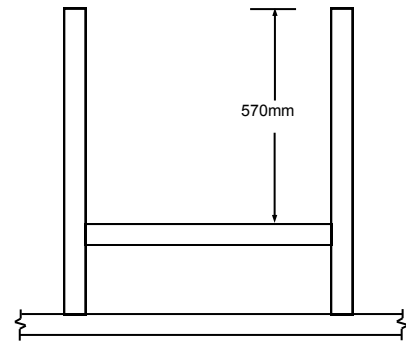

Follow Steps 2 - 5 on page 8.

Step 6: From the outside of the shed, place glass in Window Frame. Attach a Glazing Bead (G100) with three rivets to each side of the Window Frame to hold glass in place. Pre-drilling Glazing Beads is recommended.



MK2 DOOR JAMB & CORNER FLASHINGS



Step1: Fit Door Jamb Flashing (104) in between Top and Bottom Plates and hard against Stud. Attach Door Jamb Flashing with three rivets into Rib on the outside and three 30mm clouts into studs on the inside. Repeat with the other Door Jamb.



Step2: Measure and cut Doorstep Flashing (106) to fit in between Door Jamb. Position the Doorstep Flashing in between the Door Jamb at bottom of doorway, nail through top of flashing using three 30mm Clouts. Repeat with the Overdoor Flashing (105).

MK2 DOOR JAMB & CORNER FLASHINGS

Step 3: Fit Corner Flashing (101) over corner Ribs with the top flush with the top of the Top Plate. Rivet in place with six rivets, three each side. Repeat with other three Corner Flashings. When fitting Corner Flashings on front wall, ensure they are parallel with Door Jambs.



MK2 ROOF

Note: Condensation can form on the under side of shed roof. If building paper is required, fit now. Building paper will need to be supported by netting or roofing twine.

Step 1: Check that the diagonal measurements of the shed are the same. If building on unlevel ground it may be necessary to temporarily brace the shed with pieces of timber from the packaging.



Step 2: Position first Roof Sheet centrally over Ridge Beam on the right hand end of shed with the LIP on the left hand side. (For sheds with a Clear Roof Panel, go to the next page). Position the next Roof Sheet. Ensure it overlaps correctly then rivet together, 400mm down from the centre on both sides. Fit remaining Roof Sheets.



Step 3: Starting from the left hand end, centralise Roof on Ridge Beam. Ensure Roof is tight against end Wall Sheets and nail one 40mm Weatherseal through Lip into the Ridge Beam. At the back, line up Ribs on the Roof Sheet with the Ribs on Wall Sheet. Using one 40mm Weatherseal, nail through Lip into Top Plate. Repeat at the front.

Step 4: Centralize Roof at the other end and nail through Pan into the Ridge Beam and Top Plates. Ensure Ridge Beam is straight, then nail one 40mm Weatherseal into Ridge Beam beside each overlap (one nail per sheet). At the back, set up a String Line in centre of Top Plate. Ensure Top Plate is straight and nail off, using one 40mm Weatherseal per Pan. Repeat at the front.

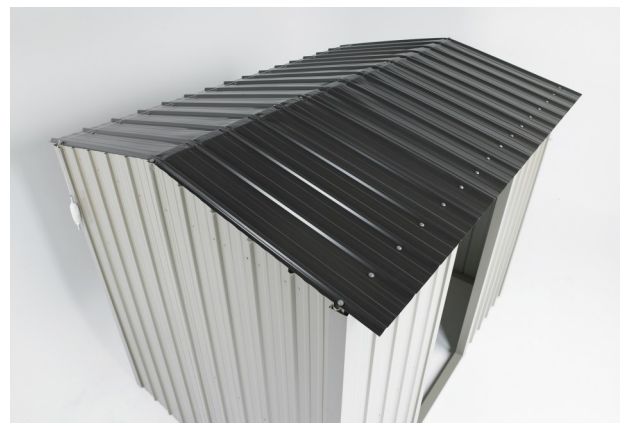

MK2 CLEAR ROOF PANEL (Optional)

- Step 1:** Position Roof Sheets at each end. Leave a gap where the Clear Panel is to be fitted. Nail on first Roof Sheet (refer to step 2 MK2 Roof).
- Step 2:** Where the Clear Roof Panel is to be positioned, nail a 45x45mm Bevelled Edge Support on each side of the Ridge Beam. (*fig. 1*)
- Step 3:** Position Clear Roof Panel and Flat Roof Sheet (or second Clear Panel). The Flat Roof Sheet underlaps one sheet and overlaps the other. The Clear Roof Panel OVERLAPS both Roof Sheets. Ensure sheet joins are flush at the outside edge then rivet flat sheets to pressed sheets. Two rivets per join. Centralise Roof at the other end and nail in place.
- Step 4:** Ensure Ridge Beam is straight, then nail the Clear Panel and Flat Roof Sheet (or second Clear Panel) to 45x45mm Bevelled Edge Supports using one 30mm Clout per Pan. Run two generous beads of Silicone on the under side of the Pressed Capping Sheet. Position Pressed Capping Sheet on Ridge Beam and nail in place using three 40mm Weatherseals. Nail one 40mm Weatherseal into Ridge Beam beside each overlap (one nail per sheet).
- Step 5:** At the Back set up a String line in the centre of the Top Plate. Ensure Top Plate is straight and nail off, one 40mm Weatherseal per Pan. Repeat at the front.

Note: When nailing through the Clear Panel, pre-drill a 6mm hole.

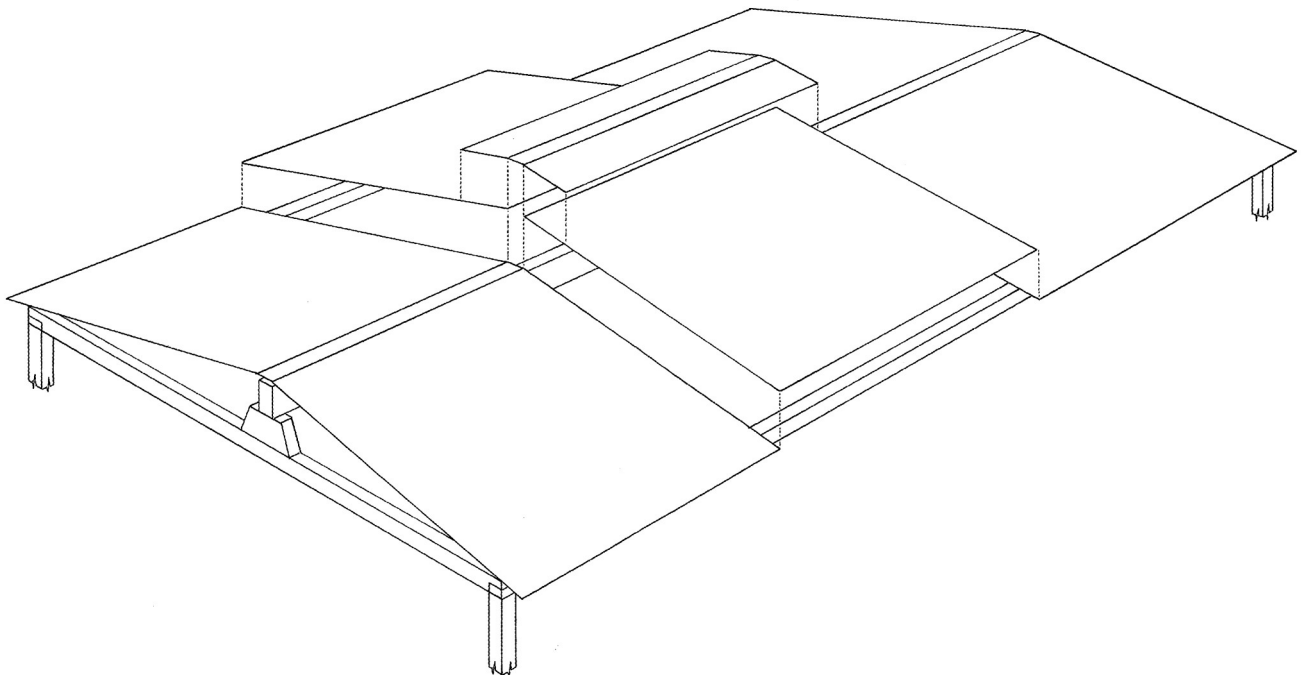
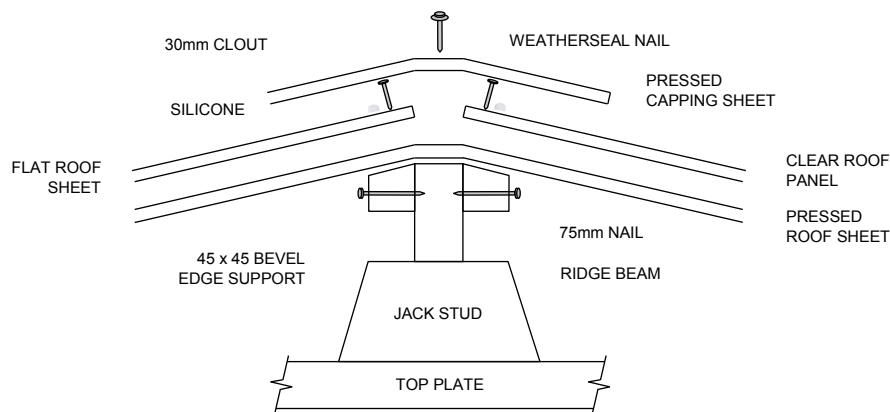

MK2 DOOR

Step 1: Position Door Track (107) on front wall up against underside of Roof, with right hand end flush with the right hand corner. Pre-drill hole in centre and rivet in place. Remove ALL drill filings.

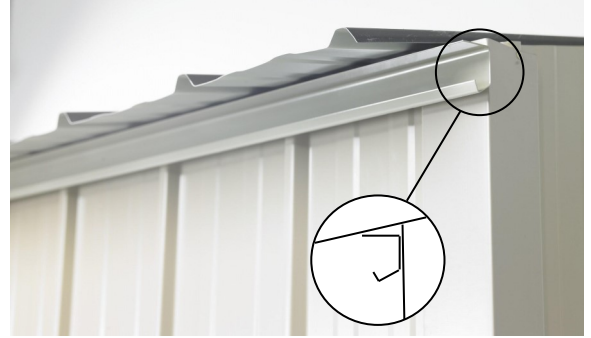

Step 2: Hang door in Door Track. At the right hand end of Door Track, adjust up or down so that the Door hangs parallel with shed. Fit one rivet at right hand end to hold in place. Repeat with left hand end of track.



Step 3: Remove Door. Pre-drill holes into each Rib and at similar spacings into Over Door Flashing. At approximately 1/3 in from each end of Door Track put a 50mm nail. Fix rivets to rest of holes.



Step 4: Clean out ALL drill filings. Also make sure the Wheels are cleaned of drill filings. Re-hang Door, then insert door stops into the pre drilled holes at end of tracks as shown in diagram. Tighten with two spanners.

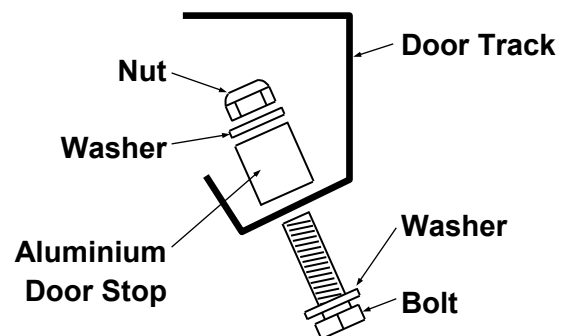

MK2 DOOR

Step 5: Bottom Door Guide: Slide Door to corner. Hang Door Guide (108) on bottom of the Door. Make it flush with Corner Flashing. Lift up approximately 3mm so that the Door will Slide freely. Pre-drill hole and nail in place using a 50mm nail. Slide to centre. Ensuring Door slides freely, pre-drill hole and nail Door Guide in place. Check Door is not binding in the middle then pre-drill holes into each Rib at similar spacing into Door Step Flashing. Nail off using 50mm nails.

Note: For sheds with Raised Base Plate option the Door Step Flashing will protrude down past the Bottom Plate. Attach Door Guide with rivets.

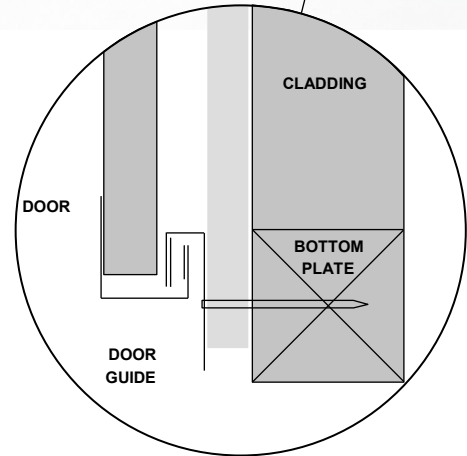
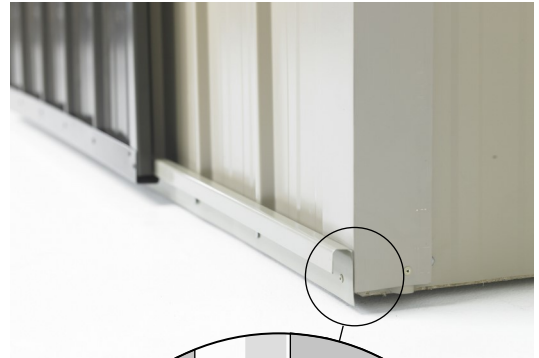

MK2 BARGE & SPOUTING



Step 1: Position Barge Flashing (102) on gable ends. Position a Spouting (B103) and rivet to the Barge Flashing at each end. Repeat with other Spouting.



Step 2: Centralise Barge Flashing on gable end and rivet in place, one rivet into every second Rib. Fit two rivets through top of Barge into Rib. Repeat with other Barge Flashing. Check Spoutings are straight, then rivet to Roof one rivet every second Rib.

MK2 FLOOR (Optional)

Step 1: Place shed in final position. Check the diagonal measurements are the same and the shed is level before fitting Floor. It is recommended that the shed is anchored down with either a Duratuf Bolt Down Kit or Duratuf Peg Down Kit depending on what the shed is sited on.

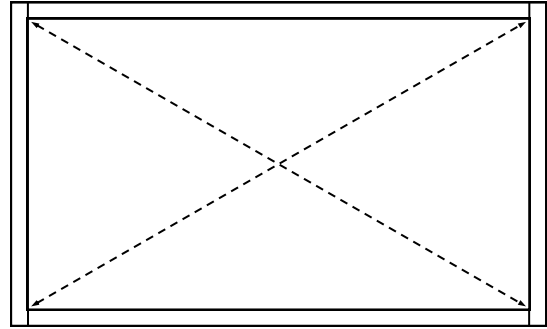

Step 2:

Lay a Floor Board on top of Bottom Plates and Joist and push up against end wall. Mark out where Studs are. Cut checkouts with Electric Jigsaw so Floor Board will fit around Studs.



Step 3: Re-position Floor Board. Lay out remaining Floor Boards checking around Studs as you go. The last Floor Board may have to be cut to size.



Step 4: Nail in each Floor Board, two 50mm nails in each end and two into Joists. Measure and cut Floor Flashing to fit in between Door Jamb Flashings and nail in place using 50mm Clouts.



MK2 HASP & STAPLE



Using six rivets and one 50mm clout attach hasp to Door Jamb Flashing and the staple to the Door as shown.

RAISED BASE PLATE

For sheds being placed on a purpose built floor, (concrete, cobbles, ply etc.), the Wall Sheets will protrude 20mm below the Base Plate. This will stop water flowing in between the Base Plate and Floor.

The Floor should be made 15mm smaller than Base Size.

Note: Although it is not essential, fitting Damp Proof Course in between the Base Plate and the Floor will give added protection against moisture.

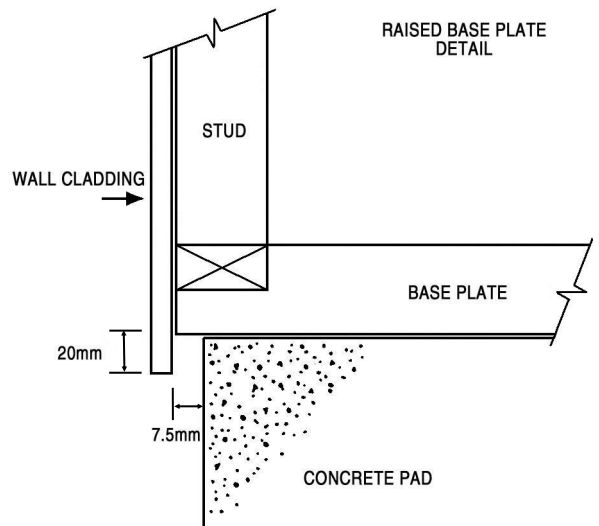

CLEAN UP

- Remove all swarf (drill filings) with a soft brush or rag.
- Hose down roof and walls thoroughly.
- For Coloursteel sheds use touch-up paint provided on all nail heads, rivets and exposed cuts.



DURATUF PREMIUM SHED WARRANTY

REFERENCE NO: _____

GUARANTEE TO CUSTOMER

Congratulations on purchasing a Duratuf Storage Shed. With proper care and attention, this product will last many years. For your benefit **PLEASE READ THE FOLLOWING INFORMATION CAREFULLY.**

WARRANTY ON METAL CLADDING

Riverlea Group Ltd guarantee that the metal roofing and wall cladding on Kiwi and Fortress Garden Sheds may be used in moderate and inland corrosion zones or areas where the first year mild steel corrosion rate is less than 200g/m², and that in these conditions, they will not perforate due to corrosion within 18 years of date of manufacture.

TERMS AND CONDITIONS

1. Damage or corrosion due to the following circumstances is not covered by this warranty.
 - ◆ Mechanical, chemical or other damage sustained during or after installation.
NOTE: Clean swarf off shed **IMMEDIATELY** after assembly
Do **NOT** mark cladding with pencil
Do **NOT** allow manures, chemicals or other corrosive materials to have direct contact with cladding
Chemical damage will result if these instructions are not carried out
 - ◆ Force majeure or other causes beyond the control of Riverlea Group Ltd.
2. This warranty does not cover material installed in severe and very severe environmental situations, or in any area where the mild steel corrosion rate (as published by BRANZ) exceeds 200g/m².
3. Minimum maintenance must be carried out in accordance with instructions below.

Should the cladding fail to perform as specified above, the liability of Riverlea Group Ltd shall in all cases be limited to replacing or repairing the defective product. The balance of the original warranty will cover any repaired or replaced material. Riverlea Group Ltd will not be liable for any consequential loss or damage, labour or transport charges. All claims made in writing within 21 days of discovery, quoting the reference number at the top right hand corner of this page.

MAINTENANCE

Following are the minimum maintenance requirements for cladding used in Kiwi Garden Sheds and Fortress Sheds.

- ◆ Washing all surfaces by rain, and annual hosing of sheltered areas using a hose and soft nylon brush.
- ◆ Within 2km of coast—wash every 3 months as above. After a storm, wash the cladding and the gutters as soon as possible to remove any highly corrosive salt deposits.
- ◆ Volcanic Ash Fallout—wash as soon as possible, removing fallout from roof and gutters
- ◆ Gutters to be kept clean of leaves and dirt.

Should you require additional technical information please contact us at the details below.

Thank you
Riverlea Group Customer Services