

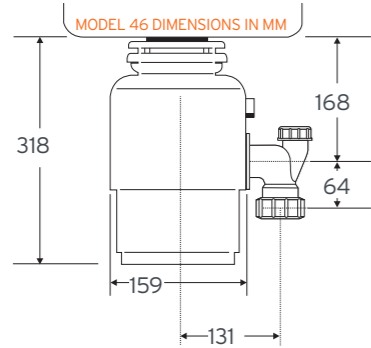

MODEL 46

FOOD WASTE DISPOSER

The entry level InSinkErator model, suitable for lighter use in smaller households.



InSinkErator reserves the right to change product specifications without prior notice. The disposers described are for household use. Usage in commercial situations is not covered by warranty.

- BASIC SOUND REDUCTION TECHNOLOGY
- AIR SWITCH KIT AVAILABLE (33MM HOLE FOR BUTTON)
- 1 STAGE GRINDING SYSTEM
- 0.55HP DURA-DRIVE™ HEAVY DUTY INDUCTION MOTOR
- GRIND CHAMBER 980ML CAPACITY
- 2 YEAR WARRANTY
- QUICKLOCK™ SINK MOUNT FOR EASY INSTALLATION
- MADE IN THE USA



MODEL 56

FOOD WASTE DISPOSER

This mid-range model is perfect for regular use in smaller households.

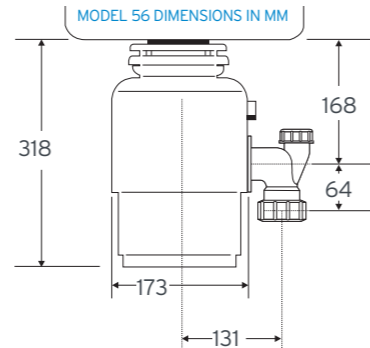

InSinkErator reserves the right to change product specifications without prior notice. The disposers described are for household use. Usage in commercial situations is not covered by warranty.

- BASIC SOUND REDUCTION TECHNOLOGY
- 0.55HP DURA-DRIVE™ HEAVY DUTY INDUCTION MOTOR
- 1 STAGE STAINLESS GRINDING SYSTEM
- QUICKLOCK™ SINK MOUNT FOR EASY INSTALLATION
- GRIND CHAMBER 980ML CAPACITY
- 3 YEAR WARRANTY
- BUILT-IN AIR SWITCH (33MM HOLE FOR BUTTON)
- MADE IN THE USA



MODEL 66

FOOD WASTE DISPOSER

The top model in our standard range, offering high performance, continuous feed operation and able to handle a wide variety of food waste.

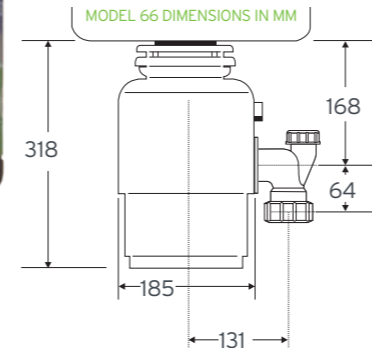

InSinkErator reserves the right to change product specifications without prior notice. The disposers described are for household use. Usage in commercial situations is not covered by warranty.

- BASIC SOUND REDUCTION TECHNOLOGY
- 0.75HP DURA-DRIVE™ HEAVY DUTY INDUCTION MOTOR
- 1 STAGE STAINLESS GRINDING SYSTEM
- QUICKLOCK™ SINK MOUNT FOR EASY INSTALLATION
- GRIND CHAMBER 980ML CAPACITY
- 4 YEAR WARRANTY
- BUILT-IN AIR SWITCH (33MM HOLE FOR BUTTON)
- MADE IN THE USA



EVOLUTION 100

TECHNOLOGY

Featuring two-stage grinding combined with SoundSeal™ Plus technology, the Evolution 100 is more powerful and quieter than our standard range. It virtually grinds any food waste, including difficult items such as bones and potato peel.

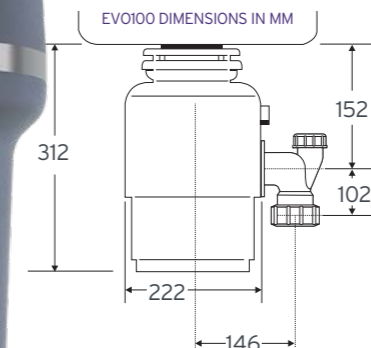

InSinkErator reserves the right to change product specifications without prior notice. The disposers described are for household use. Usage in commercial situations is not covered by warranty.

- SOUNDSEAL PLUS™ EVOLUTION QUIETER TECHNOLOGY
- 0.75HP DURA-DRIVE™ HEAVY DUTY INDUCTION MOTOR
- MULTIGRIND PLUS™ 2 STAGE STAINLESS GRINDING SYSTEM WITH AUTO REVERSE ACTION
- QUICKLOCK™ SINK MOUNT FOR EASY INSTALLATION
- GRIND CHAMBER 1005ml LARGE CAPACITY
- 5 YEAR WARRANTY
- BUILT-IN AIR SWITCH (33MM HOLE FOR BUTTON)
- MADE IN THE USA



EVOLUTION 200

TECHNOLOGY

The Evolution 200 with it's three stage grind technology & SoundSeal™ Plus, makes it our most powerful & quietest model. Don't worry about what you can and can't grind... the Evolution 200 grinds all food waste.

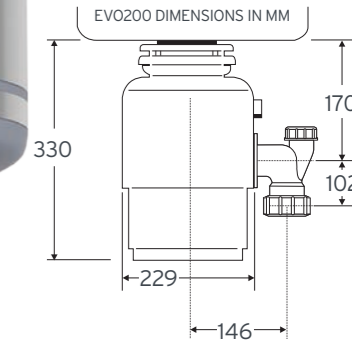

InSinkErator reserves the right to change product specifications without prior notice. The disposers described are for household use. Usage in commercial situations is not covered by warranty.

- SOUNDSEAL PLUS™ EVOLUTION ULTRA-QUIET TECHNOLOGY
- 0.75HP DURA-DRIVE™ HEAVY DUTY INDUCTION MOTOR
- MULTIGRIND PLUS™ 3 STAGE STAINLESS GRINDING SYSTEM WITH AUTO REVERSE ACTION
- QUICKLOCK™ SINK MOUNT FOR EASY INSTALLATION
- GRIND CHAMBER 1180ml LARGE CAPACITY
- 10 YEAR WARRANTY
- BUILT-IN AIR SWITCH (33MM HOLE FOR BUTTON)
- MADE IN THE USA

A LITTLE HISTORY



1927

Tinkering with an idea and some sheet metal, Racine architect John W. Hammes invents the first food waste disposer.

The 1930s

In 1935, after eight years of design refinement, he obtains U.S. Patent for his new-fangled food waste disposer.

The 1940s

Bob Cox, vice president of sales sold disposers to plumbers instead of appliance dealers and by 1952 he pitched the product out of pink Pontiac.



The 1950s

As television came of age, so did television advertising. And InSinkErator used the power of celebrity endorsements of George Burns, Barbara Walters, and later Phyllis Diller.

The 1960s

Emerson Electric Co. purchases InSinkErator.



The 1970s

InSinkErator started producing Trash Compactor and Hot Water Dispensers.

The 1990s

New York City Department of Environmental Study concluded a two-year analysis, and approved the use of food waste disposers.

2000 and beyond

InSinkErator launched the Evolution Series®. With the new series came advanced sound, grind, anti-jam and antivibration technologies.

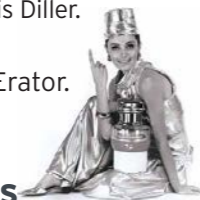

ADVANCED TECHNOLOGY

QUICKLOCK™ SINK MOUNT

"twist-on, twist-off" sink mount makes installation fast and easy.

SOUNDSEAL™ TECHNOLOGY

Anti-Vibration Mount™ Quiet Collar™ & Sound Limiter™ insulation technology.

MULTIGRIND™ TECHNOLOGY

3-stage design makes quick work of both hard and fibrous foods.

DURADRIVE™ INDUCTION MOTOR

Powerful, heavy-duty motors ensure high performance and long life.

POWERBOOST™ MICRO PROCESSOR

Delivers more power to boost the grinding capability.



Cut-away of Model Evolution 200.



SAFE ON THE SEPTIC

InSinkErator Food waste disposers have always been safe for properly sized septic systems. For example, if your system is sized for a dishwasher or clothes washer, it can handle a disposer. After all, a disposer uses only about as much water per day as one flush of a toilet.

ENVIRONMENTAL BENEFITS

Each year in New Zealand, tonnes of food waste is trucked to landfills. Once there, it quickly decomposes and produces methane, an environmentally harmful greenhouse gas at least 21 times more potent than CO2. Our food waste disposers provide a convenient and environmentally friendly alternative to transporting leftovers to landfills. Plus, capable wastewater treatment plants can even recycle food scraps into energy and fertilizer.

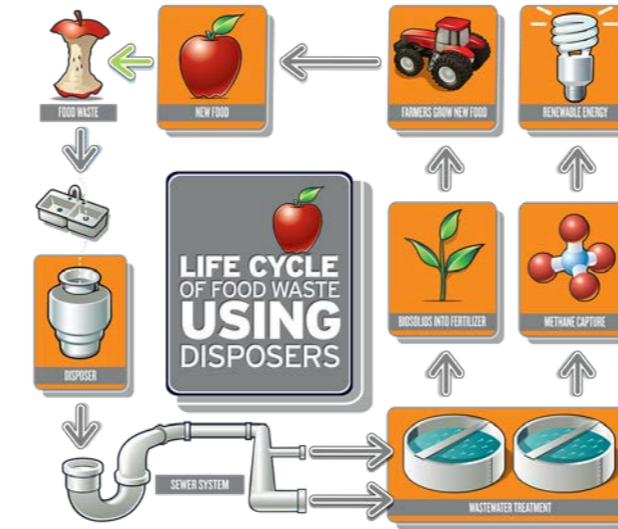

Description of wastewater treatment plant with anaerobic digestion, co-generation and beneficial reuse of bio-solids.



**FEED A DISPOSER.
STARVE A LANDFILL.**

DISPOSER ACCESSORIES

InSinkErator have a range of accessories for the Food Waste Disposers to customise the sink and colour match bench-tops.

Air Switch Covers

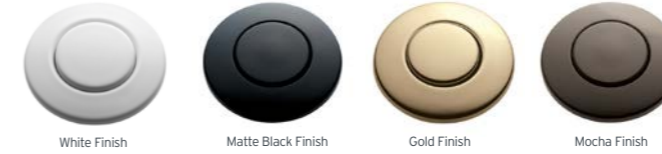

Stoppers



Sink Flanges



Strainers

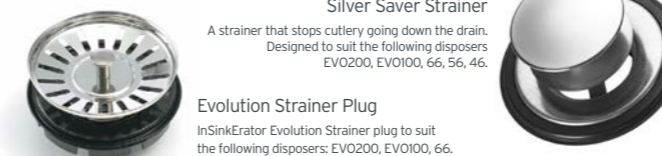

Air Switches



Air Switch Switching Kit
Replacement Air Switch Single Touch button for all InSinkErator models 45, 46, 55. Contains Button, Hose, Power cord & Plug. Brushed Steel also included.

For service and installation, call 0800 200 510 or visit www.insinkerator.co.nz



**The World's Best Selling
Food Waste Disposers!**

