

HardieGlaze™
LINING



Installation Manual

APRIL 2014 | NEW ZEALAND



James Hardie
a smarter way™

Content

1	INTRODUCTION	3			
1.1	Introduction	3			
1.2	HardieGlaze™ Smooth Lining	3			
1.3	HardieGlaze™ Tile Lining	3			
1.4	HardieGlaze™ Premium Lining	3			
2	SAFE WORKING PRACTICES	8			
3	SCOPE	10			
4	DESIGN	11			
4.1	Compliance	11			
4.2	Durability	11			
4.3	Food Preparation and Prevention of Contamination	11			
4.4	Structural Bracing	11			
4.5	'Group Number' Classification	11			
5	FRAMING/SUBSTRATE	11			
5.1	General Requirements	11			
5.2	Timber Frame	11			
5.3	Steel Frame	11			
5.4	Batten Requirements for Timber or Steel	11			
6	INSTALLATION	12			
6.1	HardieGlaze™ Lining Installation Checklist	12			
6.2	Packers	13			
6.3	Sheet Set-out and Shower Rose Location	13			
6.4	Horizontal Sheet Laying	13			
6.5	General Fixing Requirements	13			
6.6	Sheet Fixing Sequence for Showers	15			
6.7	Adhesive Fixing	14			
6.8	Adhesive/Fastfix Fixing	16			
6.9	Sheet Fixing with Fastfix Only	16			
6.10	Raised-Head Screw-Fixing Method	16			
6.11	Ceramic Tile Inserts	16			
7	JOINTING	17			
7.1	Silicone Jointing Procedures	17			
7.2	Dry Area Wall Joints	17			
7.3	Wet Area Wall Joints	17			
7.4	External Corner Joints	18			
7.5	Internal Corner Joints	18			
7.6	Wall-to-Ceiling Joints	18			
7.7	Wet Area Wall-to-Floor Joints	18			
8	SPECIAL APPLICATION	20			
8.1	Indoor Swimming Pool Application	20			
8.2	Splashback	20			
8.3	Wet Area Penetration	20			
9	PRODUCT INFORMATION	21			
9.1	Product Description	21			
9.2	Product Application	21			
9.3	Serviceable Life	21			
9.4	Sheet Properties	21			
9.5	Sheet Moisture Content and Mass	21			
9.6	Fire Properties	21			
10	MAINTENANCE	22			
10.1	General	22			
10.2	Cleaning Procedures	22			
	PRODUCT WARRANTY	23			

WE VALUE YOUR FEEDBACK

To continue with the development of our products and systems, we value your input. Please send any suggestions, including your name, contact details, and relevant sketches to:

Ask James Hardie™

Fax 0800 808 988

literaturefeedback@jameshardie.co.nz

1 Introduction

1.1 INTRODUCTION

At James Hardie, our focus is to provide you with the best. That's why James Hardie building products are the proven performers, always the right choice for your building needs.

The best products are certainly what you need when it comes to interior wall and ceiling linings in wet areas like bathrooms, kitchens, laundries and toilets. That's why you'll choose HardieGlaze™ Lining.

- Good looks and durable.
- Ease of installation with a professional finish.
- High quality, affordable and no fuss to maintain.

HardieGlaze Lining is a pre-finished wall and ceiling lining made from James Hardie fibre cement. Choose the easy-clean high-gloss polyurethane-coated finish that's right for your design needs — HardieGlaze Tile, Smooth or Premium. So simple to install and there's no backing substrate required. You can do it all yourself and complete with PVC or aluminium jointers. Silicone jointing is also available for 6.0mm HardieGlaze Lining. Because it's made from James Hardie fibre cement, HardieGlaze Lining is resistant to fire and damage from moisture*, rotting and cracking, when installed and maintained in accordance to the technical specifications in this manual.

For advice on HardieGlaze Lining, Ask James Hardie™ on 0800 808 868.

HardieGlaze Lining is only for use in internal applications.

** to the extent set out in section 8.*

1.2 HARDIEGLAZE SMOOTH LINING 4.5MM



HardieGlaze Smooth Lining is a 4.5mm square edge sheet that has a high gloss white easy to clean finish.

Can be finished with PVC or aluminium jointers.

1.3 HARDIEGLAZE TILE LINING 6MM







Enjoy the benefits of classic wet area wall patterning without the hassles and costs associated with ceramic tiles. HardieGlaze Tile Lining has three tile patterns embossed into an elegant high-gloss polyurethane coating on a 6mm-thick sanded James Hardie fibre cement surface. This eliminates the need for grouting and heavy substrates. HardieGlaze Tile Lining is available in white and features a special radiused edge allowing for silicone jointing, or with PVC or aluminium jointers.

1.4 HARDIEGLAZE PREMIUM LINING 6MM



6mm-thick HardieGlaze Premium Lining is designed for commercial and industrial interiors. Its high-gloss finish means a quick wipe is all that's needed for cleaning to ensure it will retain its good looks. HardieGlaze Premium Lining is the ideal choice in food processing and industrial areas where strict hygiene conditions apply. The radiused edges of HardieGlaze Premium Lining allow for attractive silicone jointing, or you can finish it with PVC or aluminium jointers.

Table 1

HardieGlaze Lining information						
PRODUCT	DESCRIPTION	QUANTITY / SIZE				
	HardieGlaze Smooth Lining High-gloss polyurethane finish. Is back sealed. Available in white.	THICKNESS: 4.5MM				
		LENGTH (MM)	WIDTH (MM)	COLOUR	CODE	
		2400	1200	White	400221	
		2400	900	White	400225	
  	HardieGlaze Tile Lining Square-tile pattern embossed into a hard-wearing, high gloss polyurethane coating. Is back sealed. Available in white.	THICKNESS: 6MM				
		LENGTH (MM)	WIDTH (MM)	COLOUR	CODE	
		2700	1200	White	400237	
			2400	1200	White	400240
			2400	900	White	400243
	HardieGlaze Tile Lining Grande Tile pattern embossed into a hard-wearing, high gloss polyurethane coating. Is back sealed. Available in white.	2400	1200	White	404390	
HardieGlaze Tile Lining Listello Tile pattern embossed into a hard-wearing, high gloss polyurethane coating. Is back sealed. Available in white.		2400	1200	White	404391	
		THICKNESS: 6MM				
LENGTH (MM)		WIDTH (MM)	COLOUR	CODE		
2700		1200	White	400210		
		2400	1200	White	400211	

Note:

HardieGlaze Lining must have primer applied where indicated in this manual.

All dimensions and masses provided are approximate only and subject to manufacturing tolerances.

Table 2





Joiners and mouldings for 4.5mm HardieGlaze Smooth Lining only				
	Accessory	Size (mm)	Material/appearance	Code
	Sheet Joiner	Length 2400	PVC Gloss White	300690
	Cap Mould	Length 2400	PVC Gloss White	300678
	External Corner Mould	Length 2400	PVC Gloss White	300682
	Internal Corner Mould	Length 2400	PVC Gloss White	300686
	Bath Mould 4.5mm	Length 2500	PVC Gloss White	300674
	Sheet Joiner	Length 2700	Aluminium Naturally Anodised	304507
	Cap Mould	Length 2700	Aluminium Naturally Anodised	304501
	External Corner Mould	Length 2700	Aluminium Naturally Anodised	304503
	Internal Corner Mould	Length 2700	Aluminium Naturally Anodised	304505

Table 3



Jointers and mouldings for 6.0mm HardieGlaze Lining only				
	Accessory	Size (mm)	Material/appearance	Code
	Sheet Jointer	Length 2700	PVC Gloss White	300713
	Cap Mould	Length 2700	PVC Gloss White	300695
	Internal Corner Mould	Length 2700	PVC Gloss White	300707
	External Corner Mould	Length 2700	PVC Gloss White	300701
	Bath Mould 6mm	Length 2500	PVC Gloss White	300691
	Flexible-edge 2-piece Internal PVC Corner Mould	Length 2700	PVC Gloss White	300946
	Sheet Jointer	Length 2700	Aluminium Naturally Anodised	304506
	Cap Mould	Length 2700	Aluminium Naturally Anodised	304500
	Internal Corner	Length 2700	Aluminium Naturally Anodised	304504
	External Corner	Length 2700	Aluminium Naturally Anodised	304502
	Negative Jointer	Length 2700	Aluminium Naturally Anodised	305212
	Sheet jointer	Length 2700	Aluminium White	305750
	Cap mould	Length 2700	Aluminium White	305751
	Internal Corner	Length 2700	Aluminium White	305749
	External Corner	Length 2700	Aluminium White	305748

Table 4

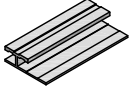
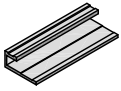
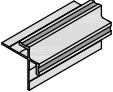
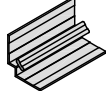

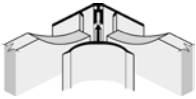
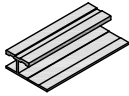
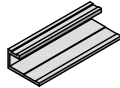
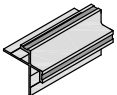
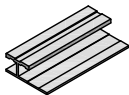
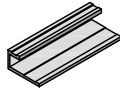
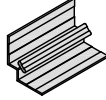
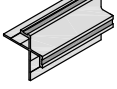

HardieGlaze Lining accessories for the full 4.5mm and 6mm range				
	Accessory	Size (mm)	Material/appearance	Code
	Fastfix Fasteners	Length 40 100 per pack	Nylon Gloss White	300632
	Scotia Mould	Length 2400	PVC Gloss White 2-piece Base and Cap	300916
	Touch-up Paint Kits	15ml	White	
	HardieBlade Saw Blade	185ømm		300660
	James Hardie Two Sided Adhesive Tape To go on timber framing as optional fixing used in conjunction with adhesive fixing	12mm x 33m	Red Tape	305433

Table 5

Components not supplied by James Hardie			
The following products are for use in conjunction with HardieGlaze Lining. James Hardie does not supply these products. Please contact component manufacturer for information on their warranties and further information on their products.			
Accessory	Brands	Unit	Quantity
	Score-and-snap knife		
Sealer	Dulux Acraprime 501/1, Dulux Primercyl or similar	Tin	
Bond Breaker	Sellotape 5850 Super Mask 18mm To go behind sealant joint	Roll	55m
Adhesive	Fullers Max Bond, Selley's Liquid Nails, Sika Nailbond Fast, Sika Nailbond® PB, Sika 'Sikaflex-11FC', Bostik 'Seal N Flex -1' or Bostik Tuf As Nails.	Cartridge	
Masking Tape	3M Scotch™ Long-Mask™ #2090 or Sellotape 5855 Long Life	Roll Roll	50m 55m
Sealant	Sika Sikasil NG (translucent) or Sika Sikasil RTV (+ SikaPrimer-3N), Sika Sikasil Wet Areas or Fullers 770 Sanitary.	Cartridge	
Cleaners	Refer clause 10.2		
C-25 Brad Nail	Paslode For fixing aluminium jointer to timber	Box	
Fibreshear Cutter	Accent Tools (09) 415 2545		

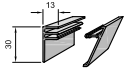
2 Safe working practices

WARNING – AVOID BREATHING SILICA DUST

James Hardie products contain sand, a source of respirable crystalline silica which is considered by some international authorities to be a cause of cancer from some occupational sources. Breathing excessive amounts of respirable silica dust can also cause a disabling and potentially fatal lung disease called silicosis, and has been linked with other diseases. Some studies suggest smoking may increase these risks. During installation or handling: (1) work in outdoor areas with ample ventilation; (2) minimise dust when cutting by using either ‘Score and Snap’ knife, fibre cement shears or, where not feasible, use a HardieBlade™ Saw Blade and dust-reducing circular saw attached to a HEPA vacuum; (3) warn others in the immediate area to avoid breathing dust; (4) wear a properly-fitted, approved dust mask or respirator (e.g P1 or P2) in accordance with applicable government regulations and manufacturer instructions to further limit respirable silica exposures. During clean-up, use HEPA vacuums or wet cleanup methods – never dry sweep. For further information, refer to our installation instructions and Safety Data Sheets available at www.jameshardie.co.nz

FAILURE TO ADHERE TO OUR WARNINGS, SAFETY DATA SHEETS, AND INSTALLATION INSTRUCTIONS MAY LEAD TO SERIOUS PERSONAL INJURY OR DEATH.

James Hardie recommended safe working practices

CUTTING OUTDOORS

1. Position cutting station so wind will blow dust away from the user or others in working area.
2. Use one of the following methods based on the required cutting rate:

BEST

- Score and snap
- Hand guillotine
- Fibreshear

BETTER

- Dust reducing circular saw equipped with HardieBlade™ Saw Blade and HEPA vacuum extraction.

GOOD

- Dust reducing circular saw with HardieBlade™ Saw Blade.

CUTTING INDOORS

- Cut only using score and snap, hand guillotine or fibreshears (manual, electric or pneumatic)
- Position cutting station in well-ventilated area

SANDING/REBATING/DRILLING/OTHER MACHINING

When sanding, rebating, drilling or machining you should always wear a P1 or P2 dust mask and warn others in the immediate area.

IMPORTANT NOTES

1. For maximum protection (lowest respirable dust production), James Hardie recommends always using “Best” — level cutting methods where feasible.
2. NEVER use a power saw indoors.
3. NEVER use a circular saw blade that does not carry the HardieBlade™ logo.
4. NEVER dry sweep — Use wet suppression or HEPA vacuum.
5. NEVER use grinders.
6. ALWAYS follow tool manufacturer’s safety recommendations.

P1 or P2 respirators can be used in conjunction with above cutting practices to further reduce dust exposures. Additional exposure information is available at [www.jameshardie.co.nz](#) to help you determine the most appropriate cutting method for your job requirements. If concern still exists about exposure levels or you do not comply with the above practices, you should always consult a qualified industrial hygienist or contact James Hardie for further information.

Handling and storage

HardieGlaze Lining sheets must be stacked flat on a smooth level surface. Protect edges and corners from damage. Carry sheets on edge. Store under cover and keep dry prior to fixing.

Note: Stacking the sheets on edge may cause damage to the radius sheet edges on HardieGlaze Tile and Premium Lining.

HardieGlaze Tile and Premium Lining have a protective, removable film. Leave this in place until after installation is completed. Before fixing begins, check the batch numbers on each sheet to ensure colour match. Measurements and cutting line can be marked on the film which also keeps the product clean and scratch free.

Always top stow the product when in transit or when on site.

Cut-edge sealing

Before any sealants are applied to site-cut HardieGlaze Lining sheet edges, the raw edge must be site primed. Use Dulux Primercryl, Dulux Acraprime 501/1 or similar. Be careful not to miss any areas. All site-cut sheet edges for silicone joints must be site sealed. All HardieGlaze Premium Lining sheet edges must be sealed for all installations. For best results in shower applications always use the factory-finished edge for the bottom drip edge.

Working instructions

Refer to recommended Safe Working Practices before starting any cutting or machining of product.

Score-and-snap

Score-and-snap is a fast and efficient method of cutting. Use a special tungsten tipped score-and-snap knife (refer to illustration).

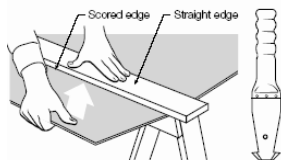

- Position the straight-edge along the line of the cut.
- Score against the straight-edge and repeat the action to obtain adequate depth for a clean break — normally one-third of the sheet thickness.
- Snap upwards to achieve break.
- Clean up the edges with a rasp and sandpaper if necessary.

Note: The straight-edge must be firmly held as the coating on the surface can easily cause it to slip and damage the coating.

HardieBlade Saw Blade

The HardieBlade Saw Blade used with a dust-reducing saw connected to a HEPA vacuum is ideal for fast, clean cutting of James Hardie fibre cement products.

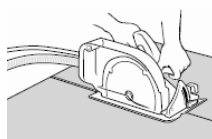

A dust-reducing saw uses a dust deflector or a dust collector connected to a vacuum system. When sawing, clamp a straight-edge to the sheet as a guide and run the saw base plate along the straight edge when making the cut.

Hole-Forming

For smooth clean cut circular holes:

Mark the centre of the hole on the sheet. Pre-drill a 'pilot' hole.

Using the pilot hole as a guide, cut the hole to the appropriate diameter with a hole saw fitted to a heavy duty electric drill.

For irregular holes:

Small rectangular or circular holes can be cut by drilling a series of small holes around the perimeter of the hole then tapping out the waste piece from the sheet face.



Tap carefully to avoid damage to sheets, ensuring that the sheet edges are properly supported.

The following alternative method can be used for square or rectangular wall openings:

- Mark the outside of the hole on the face side of sheet.
- Drill a hole in each corner as shown.
- Score to the outside of the holes to half of the sheet depth.
- Turn the sheet over and score the reverse face of the sheet.
- Knock out the hole and clean up with a rasp and coarse sandpaper.

For rectangular holes:

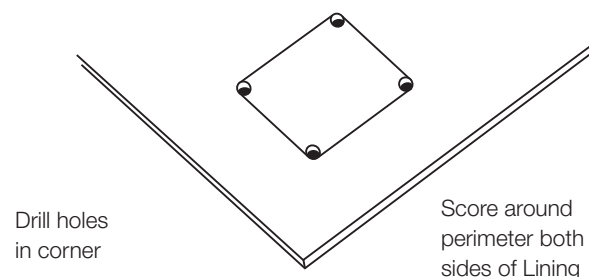

Quality

James Hardie conducts stringent quality checks to ensure that any product manufactured falls within our quality spectrum. It is the responsibility of the builder to ensure that the product meets aesthetic requirements before installation. James Hardie will not be responsible for rectifying obvious aesthetic surface variations following installation.

3 Scope

Table 6

HardieGlaze Lining is suitable for use in wet or dry areas that require a sealed, impervious surface and is easy to clean for residential or commercial applications as explained in the table below.

HardieGlaze Lining is also suitable for use in areas which require protection from dirt and bacteria build-up.

HardieGlaze Premium can also be used in strict hygiene areas where the entire surface must be easy to clean and completely impervious to meet hygiene requirements for food processing and preparation.

Application examples		HardieGlaze Lining options
Residential	Commercial	
Showers Laundries Bathrooms Toilets Kitchens	Changing rooms Shop linings Veterinarian clinics Butcher shops Commercial kitchens Industrial and commercial showers and wet area linings	Smooth* Tile* Premium*
Strict hygiene:		Premium* only with silicone joints. Silicone sealant must be approved for use in food/hygiene areas. Refer to sealant manufacturer for information.

*Maximum serviceable temperatures up to 60°.

Figure 1: HardieGlaze Tile Lining pattern

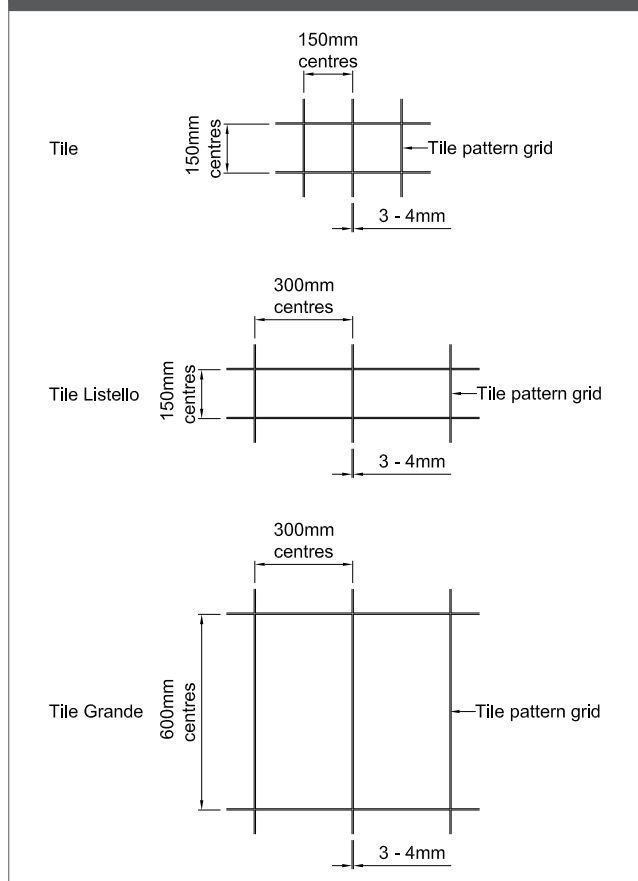
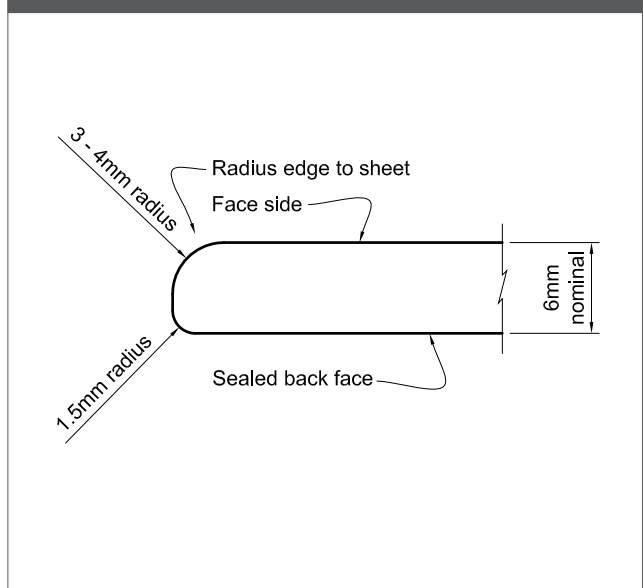

Figure 2: HardieGlaze Tile and Premium Lining edge finish



Notes:

1. The paint finish is carried to the sheet radius edge to allow for silicone sealant joints to be used in the installation.
2. Where possible sheet edges with greater coverage (typically one end) are best orientated so that they are the lowest edge.

4 Design

4.1 COMPLIANCE

HardieGlaze Lining complies with section 3.1.2 of clause E3/AS1 of the New Zealand Building Code (NZBC). HardieGlaze Lining must be installed in accordance with this specification to satisfy the relevant provisions of the NZBC.

4.2 DURABILITY

HardieGlaze Lining is not susceptible to long-term moisture damage. When jointing, sealing, flashing and coating details (as outlined in this specification) are maintained, HardieGlaze Lining is expected to have a serviceable life of at least 15 years.

4.3 FOOD PREPARATION AND PREVENTION OF CONTAMINATION

The surface of HardieGlaze Premium Lining also complies with the requirements of Clause G3 of the NZBC, when fixed to the strict hygiene requirements of this installation manual.

4.4 STRUCTURAL BRACING

Because the sheets are adhesive-fixed they are not suitable for structural sheet bracing. When structural sheet bracing is required, mechanically fix a sheet of Villaboard® Lining to give the bracing rating required, then adhesive-fix the HardieGlaze Lining onto the face of the Villaboard Lining. Refer to the James Hardie Design Manual for further bracing information.

4.5 'GROUP NUMBER' CLASSIFICATION

Internal wall linings are required to be tested to establish their 'Group Numbers' in accordance with ISO 5660 or ISO 9773 specified in 'Protection from Fire' clause C of the NZBC. HardieGlaze Lining has been tested and has 'Group Number 1-S' classification. This is the best performance that can be expected of a prefinished wall lining.

5 Framing/ substrate

5.1 GENERAL REQUIREMENTS

HardieGlaze Lining can be fixed directly to both timber and steel frame construction, load bearing and non-load bearing. All framework for walls and ceilings must comply with this specification and applicable current New Zealand standards.

Studs must be spaced at a maximum of 600mm centres with continuous top and bottom plates and nogs at 1200mm maximum centres.

Sheet fixing tolerances are at a minimum when a steel frame is used, therefore setting out must be accurate.

5.2 TIMBER FRAME

Timber framing must be in accordance with NZS 3604 'Timber Framed Buildings'. Refer to NZS 3602 regarding treatment requirements and allowable moisture contents of timber. Specific design to NZS 3603 and AS/NZS 1170 can also be undertaken providing that:

- the framing centres do not exceed those given in this specification;
- the framing member widths conform to this specification.

HardieGlaze Lining must not be fixed to timber framing that exceeds the required specified moisture content as per NZS 3602. Timber framing is to be 45mm minimum width.

5.3 STEEL FRAME

The details in this brochure are drawn for timber framing. However, steel framing can also be used at the same framing centres as for timber frame.

Steel framing members of load-bearing construction must be fabricated from light-gauge sheet steel 0.55mm to 1.6mm thick.

Steel framing for non load-bearing construction must be a minimum of 0.55mm thick. The frames must be firmly secured together and must not rely on the sheeting for stability. The minimum flange width of 38mm is required to adequately adhere the sheets. Instructions by the proprietary framing manufacturer must be followed.

Figure 3: HardieGlaze Lining batten layout

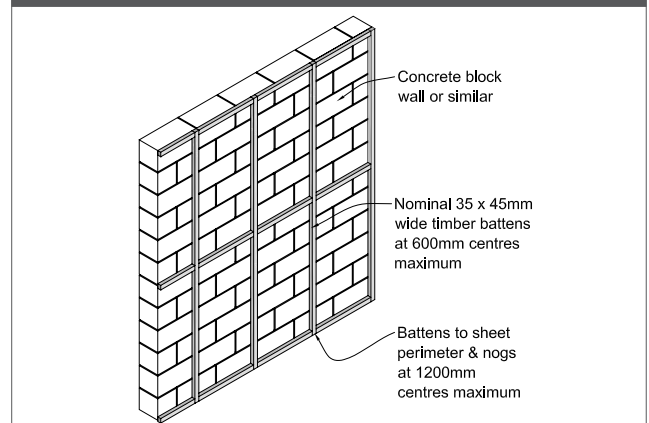

Note: Steel battens 72mm wide x 23mm deep x 0.55mm thick, with a minimum bearing surface of 38mm and with minimum 275g/m² zinc coating, can also be used.

5.4 BATTEN REQUIREMENTS

Timber/steel battens are required when sheets are fixed over:

- polystyrene or similar substrates;
- concrete, masonry block or brick.

Allow concrete or block walls to dry out before battening and ensure that all exterior faces are adequately sealed.

5.4.1 BATTENING SPECIFICATION

Refer to Figure 3. Take care to ensure the battens are packed and aligned to give a true even surface for the sheets to be fixed. Check the face of the battens with a long straight-edge before fixing the sheets.

5.4.2 FIXING TO FIBRE CEMENT OR PLASTERBOARD

HardieGlaze Lining can either be fixed directly to the framing or fixed directly over James Hardie Villaboard Lining or plasterboard.

6 Installation

6.1 HARDIEGLAZE LINING INSTALLATION CHECKLIST

Step 1: Before you start

- Read the information in this manual. Note that HardieGlaze Lining is NOT suitable for floors, benchtops, exterior cladding or exterior signage.
- Check that timber for framing is dry — the moisture content as per the NZS 3602 (refer page 11).
- Check the sheet batch numbers to ensure the sheets are all from the same batch to be colour matched.
- Ensure the timber and sheet surface are free from any dirt or grime before installation.

Step 2: Assemble your tools

- Caulking gun
- Hand saw
- Hammer
- Electric drill and titanium bits
- Level
- Tape measure
- Saw horses
- Rasp
- Pencil
- Score-and-snap knife.

Step 3: Check your materials

- HardieGlaze Lining sheets 900mm or 1200mm wide.
- Solvent-based wallboard adhesive (refer page 14).
- PVC or aluminium sheet jointers and mouldings (refer Tables 3-5).
- Silicone sealant (refer Figures 14 and 15) and recommended masking tape.
- Polyurethane bondbreaker tape.
- Timber cut to length for temporarily bracing sheets into place (refer page 16).
- Batch no.s are identical.
- Arrow directions on tile.

Step 4: Choose the installation method

- Ascertain the correct HardieGlaze Lining sheets to meet your specific requirements (refer Tables 1, 6 and 7).
- Choose the appropriate fixing method (refer Table 7).
- Choose the appropriate edge sealing and jointing method.

Step 5: Prepare your walls

- Check framing for flatness and straightness. Plane back any timber high spots.
- Check that all framing is secure and well nailed.
- Punch all framing nails.
- Check that all plumbing and electrical fittings are fixed in the correct location.
- Accurately measure the distances between framing for sheet sizes. Measure at the top, bottom and centre of the frame as a check, and allow tolerances so the sheet will fit easily.

Step 6: Measure the sheets

- When cutting, accurately measure and mark out on the face of the sheet (use a soft builder's pencil). Allow 1 to 2mm clearance each side to fit into jointers.

- When using mouldings, accurately measure the mould to work out allowances for fitting into the moulding.
- Allow for sealant width when using silicone joints.

Step 7: Cut and form the sheets

- Accurately cut the sheets (refer page 8).
- Mark out positions of holes or penetrations in sheets (refer page 9).
- HardieGlaze Lining sheets with cut edges must be site prepared and primed before applying sealant (refer page 9).
- Lining sheets to baths or bottom of showers must have bottom edge and back 100mm sealed (refer to Figure 19, 20 and 21).

Step 8: adhesive, sealant and install the sheets

- Refer to Section 7 for jointing options. Always ensure the timber or sheet surface are free from any dirt or grime before installation.

For aluminium jointing:

- Fix the jointer to the studs first.
- Place sealant in jointers if required (refer Figure 17).
- Fit the sheet into jointer and press onto the adhesive daubs applied over timber frame and pack the sheet off the floor or base with 6mm minimum packers. Hold the sheet in place until temporary bracing is applied.
- When using James Hardie two sided adhesive tapes in conjunction with adhesives, no temporary bracing is required.
- When fixing in a three sided shower, fix the first sheet onto the adhesive with the jointers on both sides of the sheet in place.
- Fix the second and subsequent sheets in place with the jointer to one edge as required (refer section 6.6).
- Ensure that all sheets are truly aligned and fit tightly into jointers, then temporarily brace into place.

For silicone jointing:

- Fix bond breaker tape to the framing behind the joints before fixing sheets (refer Figure 15).
- Press the sheets onto adhesive daubs/bead applied over timber frame and pack the sheet off the floor or base with 6mm minimum packers. Hold the sheet in place until temporary bracing is applied (refer Figure 11).
- Space the correct gap between sheet edges.
- Apply sealant between joints.
- Do not touch silicone sealant with bare fingers as this can encourage mould growth.

Note: A spacer gives the correct gap for HardieGlaze Tile and HardieGlaze Premium Lining (refer to Figure 15).

Sealing Penetrations:

- Apply sealant around taps and fixture penetrations after fixing the sheets into place (refer pages 17–20).

Step 9: Finishing touches

Only use specific masking tapes on surface, refer Table 5. Incorrect tapes can cause coating removal.

- Clean up all sheets and jointers with kerosene on a clean cloth to remove all pencil marks, adhesive or excess sealant.
- Remember to maintain the sheets and clean on a regular basis (refer page 22).

6.2 PACKERS

Use 3mm-4mm thick packers for packing the frame when 6mm HardieGlaze Lining is being used with standard rebated jambs or other situations where the thickness needs to be increased (refer Figure 4).

Figure 4: HardieGlaze Lining jamb rebate

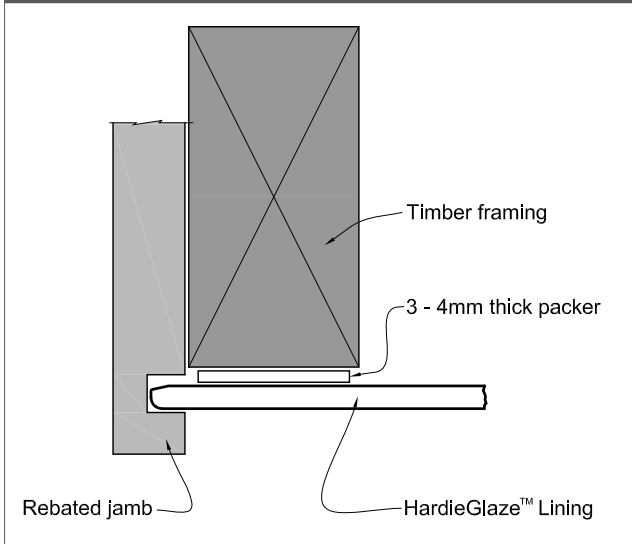

6.3 SHEET SET-OUT AND SHOWER ROSE LOCATION

The vertical set-out of HardieGlaze Tile Lining is important because of its pattern. Choose a horizontal set-out datum line because the module must coincide with the horizontal tile pattern line (refer Figure 5). Set out all sheets to this. The shower rose must be positioned below any ceramic tile inserts or horizontal sheet joints (refer Figure 6). This is to stop water from the shower rose running behind the HardieGlaze sheet.

Figure 5: HardieGlaze Tile Lining vertical setout

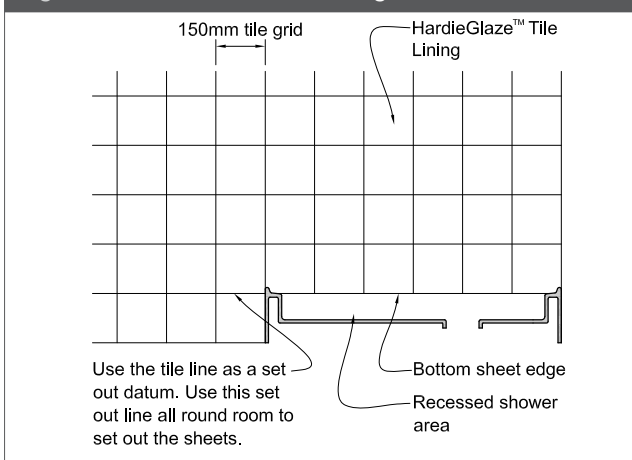

Note: Sheet set-out is important in visible areas of the room. Use full sheets in these areas and save part sheets for less visible corners. If tile pattern set out allows use a factory finished bottom edge in wet areas. Seal bottom edge and 100mm up back of sheet with Dulux Primercryl , Dulux Acraprime 501/1 or similar.

Figure 6: Shower rose location setout

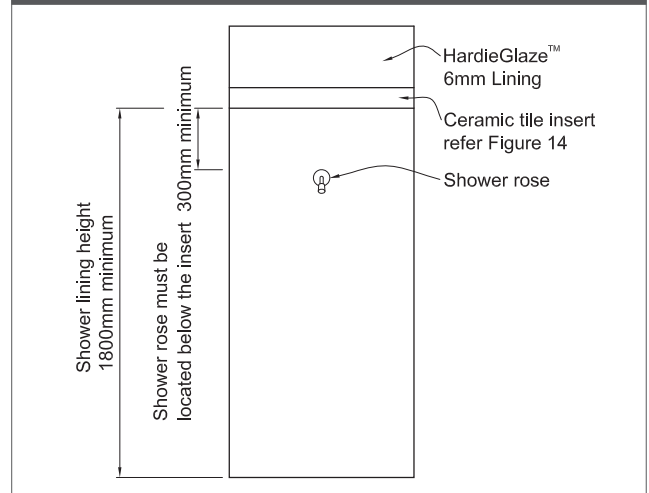

6.4 HORIZONTAL SHEET LAYING

When a ceramic tile insert (refer Figure 14) is required at the 1200mm dado height, HardieGlaze Tile Lining can be laid horizontally. Ensure arrows are facing in the same direction for all sheets.

6.5 GENERAL FIXING REQUIREMENTS

All fixing for walls and ceilings must comply with this specification. At all adhesive-fixed sheet joints, the centre line of the joint must coincide with the centre line of the stud, nog or plate.

This is to ensure sufficient adherence of adjoining sheets to the frame along the sheet edges.

Best practice notes: In wet areas where possible always:

1. Use a factory sealed edge at the bottom.
2. If there is any variation in quality of the factory sheet edges, put the best sheet edge to the bottom.

Fix the sheet from the centre working towards the outside, to avoid drumminess. Fix 4.5mm and 6mm HardieGlaze Lining to the timber or steel frame using solvent-based or foam polyurethane wallboard adhesive (to the centres shown in the relevant diagrams), to the perimeter of all sheets, intermediate studs, plates and nogs. For further adhesive instructions refer to pages 14, 15 and 16.

Sheets must be fixed 6mm clear of the floor for general wall applications. Care must be taken to ensure that this gap does not become filled with residue during the construction process.

Fix pvc or aluminium mouldings with nails or screws at 300mm max centres.

Aluminium mouldings may also be fixed to frame with C-25 brad nails at 300mm maximum centres.

For sheets with a shower base refer to Figures 19, 20 and 21.

6.6 SHEET FIXING SEQUENCE FOR SHOWERS

In shower boxes with sheets on three sides, the fixing sequence is important. Fix the rear sheet first with the jointers in place, then fix the remaining two sheets on sides.

6.7 ADHESIVE FIXING

Adhesive fixing is used to avoid fixing penetrations in the sheet face. Fix HardieGlaze Lining to the framing with a good-quality polyurethane wallboard adhesive.

For adhesive fixing the HardieGlaze Lining sheet can either be fixed in conjunction with James Hardie two sided adhesive tape or the sheet can be temporarily braced for approximately 24 hours to allow the adhesives to cure and gain full adhesion. When using two sided adhesive tape, apply 150mm long strip of tape on the framing in between daubs of adhesive which are applied at 200mm c/c to the entire framing. Refer to Figure 10. Do not apply double sided tape on the stud where an aluminium jointer is fixed as the tape will not allow the HardieGlaze Lining sheet to slide into the jointer.

When using the temporary bracing method always ensure that the edges and the sheet surface is braced adequately and protect the sheet surface against scratching. The bracing member should be aligned with the framing behind HardieGlaze Lining. Support and temporarily brace the sheets during adhesive setting, in accordance with the adhesive manufacturer's instructions (refer to Figure 11). Ensure timber braces are aligned over solid framing behind.

Wallboard adhesives should be suitable for HardieGlaze Lining application in accordance with this manual. Recommended adhesives include: **Sika Nailbond Fast, Sika NailBond® PB, Fullers Maxbond, Bostik Tuf As Nails, Bostik 'Seal-N-Flex-1', Selleys Liquid Nails, Sikaflex-11FC** or similar. Refer to adhesive manufacturers' recommendations to ascertain suitability for the intended use.

- Clean the frame surface before applying the adhesive. Also clean the back surface of HardieGlaze Lining before fixing to remove any loose material/dust.
- Never force sheets into position.
- Place daubs of wallboard adhesive on intermediate studs or battens and nogs at 200mm centres (refer Figures 7 and 8).
- Refer to adhesive manufacturer's recommendations

to ascertain if adhesive installation should be daubs or continuous bead and the appropriate size of either.

- Fit aluminium sheet jointers to both sides of the HardieGlaze Lining sheet or allow spacings between the sheets for silicone joints.
- In wet areas, you must use silicone sealant in the aluminium jointers and mouldings.
- The aluminium sheet jointers are brad nail fixed into position at 300mm max centres.
- The edge of the sheets must be spaced appropriately when silicone jointing method is used.
- Once the sheets are adhesive fixed and finally in place, either the temporary bracing is required or adhesive tape is used to hold the sheet (refer Figure 10). Always protect the sheet surface against scratching.

Notes:

1. Refer to adhesive manufacturer's recommendations for use.
2. The contact method of adhesive bonding can also be used by experienced builders.
3. Ensure the room is well ventilated when working with solvents.

Figure 7: HardieGlaze Lining sheet fixing to walls including shower cubicles — adhesive method

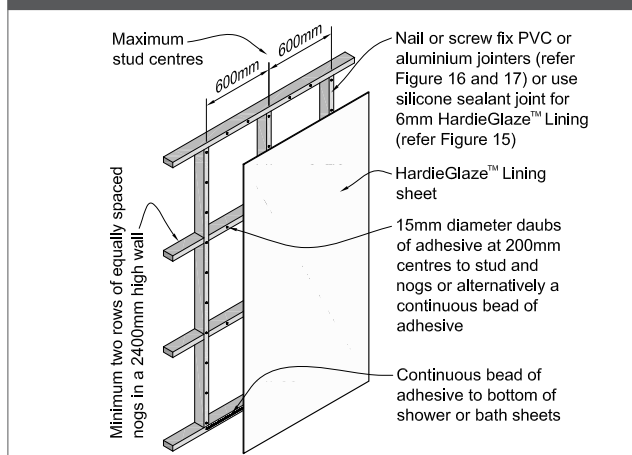

Note: For high impact areas extra nogs must be provided, or fix 6mm Villaboard Lining to the framing before installing HardieGlaze Lining.

Table 7

Fixing for specific applications		
Specific application	HardieGlaze Lining	Fixing method options for walls and ceilings
Wet or dry areas that require a sealed impervious surface	Smooth Tile Premium	Use one of the following: <ul style="list-style-type: none"> • Adhesive (for walls, refer Figure 7; for ceilings, refer Figure 8). • Adhesive/Fastfix (for ceiling, refer Figures 9 and 12).
Dry areas	Smooth Tile Premium	Use one of the following: <ul style="list-style-type: none"> • Adhesive (for walls, refer Figure 7; for ceilings, refer Figure 8). • Adhesive/Fastfix (refer Figures 9 and 12). • Full Fastfix (refer Figure 12). • Screw (refer Figure 13).
Wet or dry areas that require moderate protection from dirt and bacteria	Smooth Tile Premium	Use one of the following: <ul style="list-style-type: none"> • Adhesive (for walls, refer Figure 7; for ceilings, refer Figure 8). • Adhesive/Fastfix (for ceiling, refer Figures 9 and 12).
Strict hygiene (MAF compliance)	Premium	Walls: <ul style="list-style-type: none"> • Adhesive (refer Figure 7). Ceilings: <ul style="list-style-type: none"> • Adhesive (refer Figure 8)

Figure 8: HardieGlaze Lining sheet fixing to ceilings — adhesive method

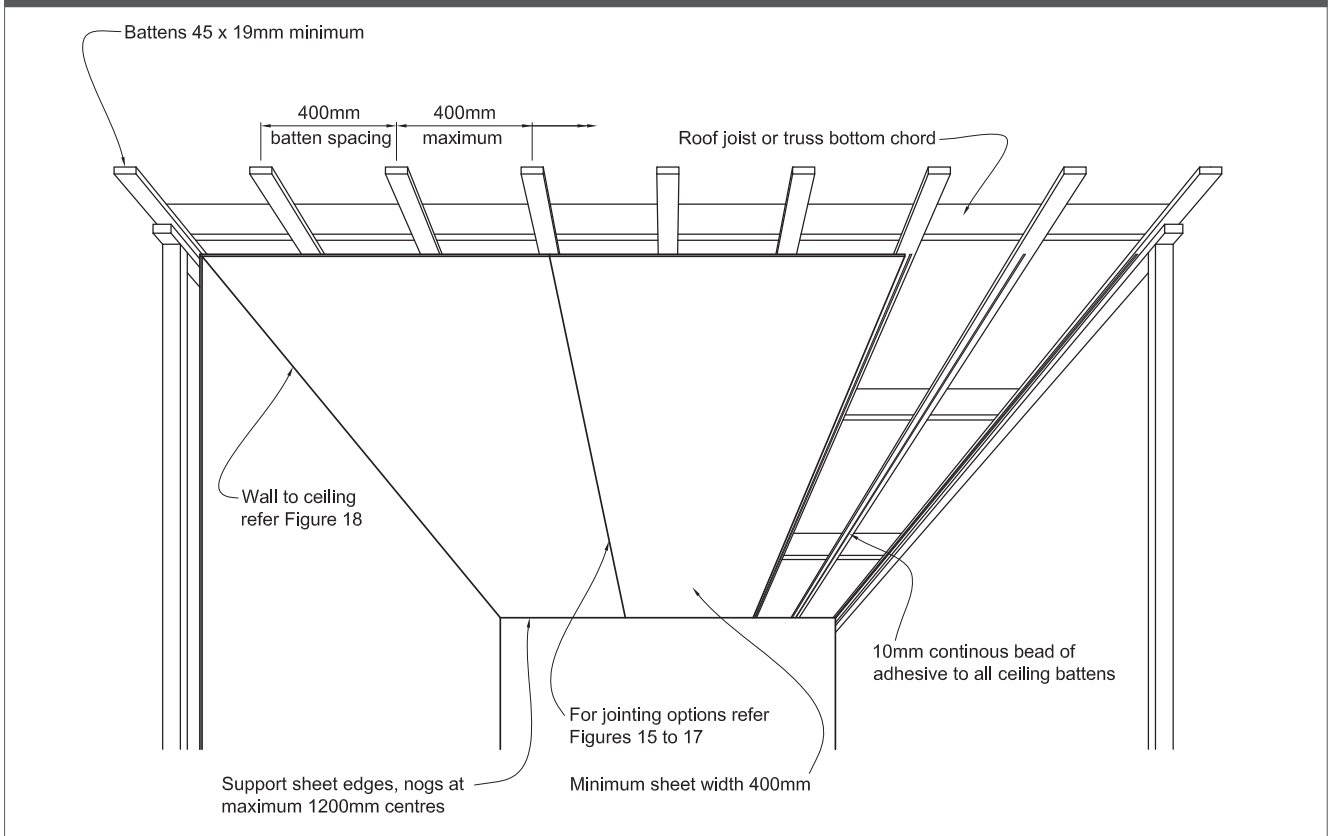

Note: This method requires the sheets to be fully braced temporarily while the adhesive cures (refer Figure 11). Bracing member should be aligned with the framing behind HardieGlaze Lining.

Figure 9: HardieGlaze Lining sheet fixing to ceilings and walls adhesive/fastfix method

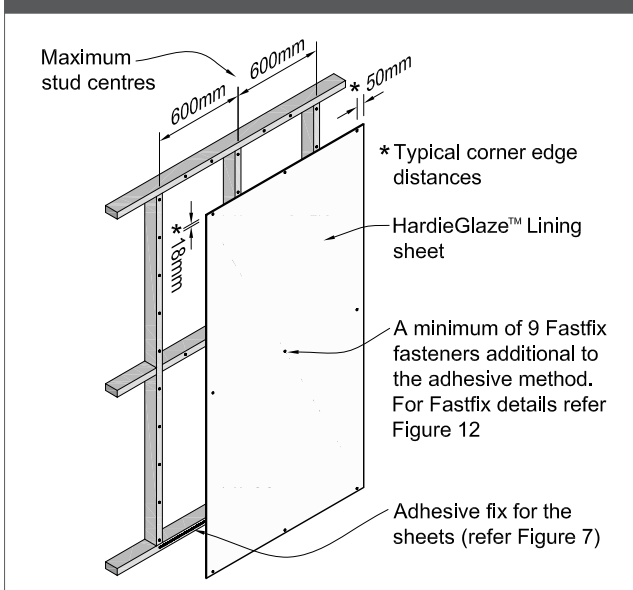

Note: For high impact areas extra nogs must be provided, or fix 6mm Villaboard Lining to the framing before installing HardieGlaze Lining.

Figure 10: HardieGlaze Lining sheet fixing to walls — tape and adhesive method

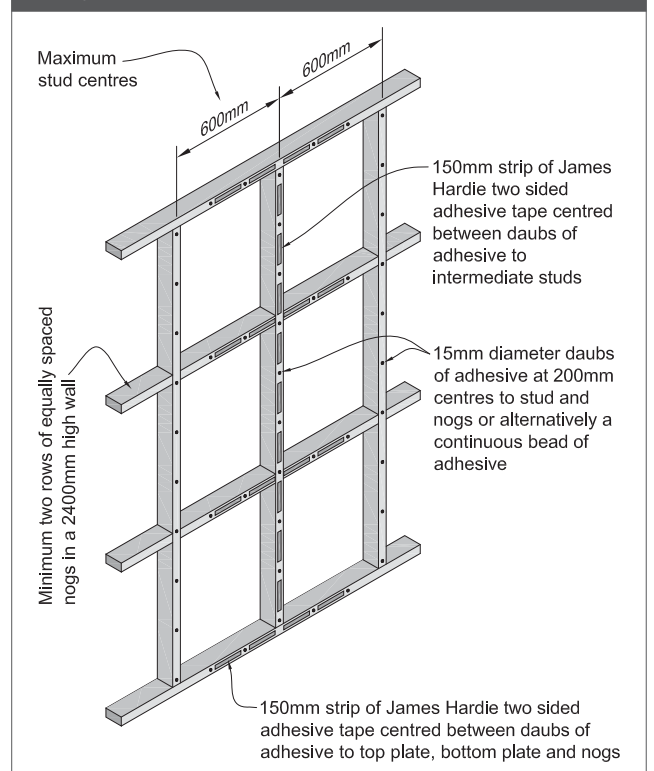
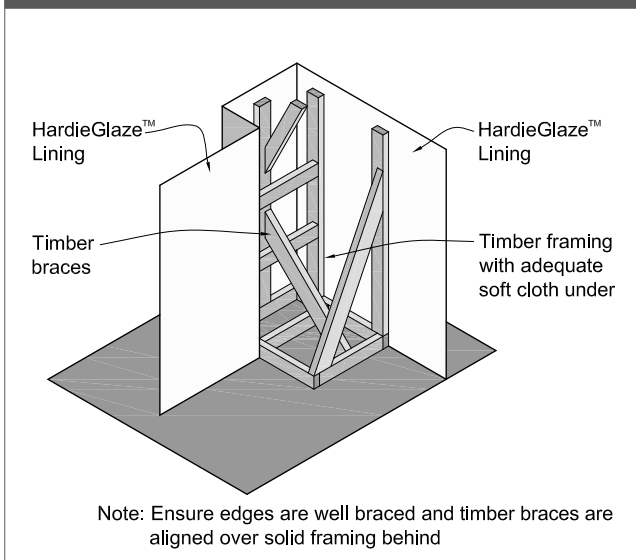

Figure 11: Temporary HardieGlaze Lining sheet bracing



6.8 ADHESIVE/FASTFIX FIXING

This method uses adhesive as the main sheet fixing, combined with a minimum number of Fastfix fasteners to hold the sheet in place while the adhesive sets. This method is particularly suitable for ceilings where temporary bracing may be difficult (refer Figure 9).

Note: Temporary bracing must be applied to the sheet areas between the Fastfix fasteners, to avoid sag.

6.9 SHEET FIXING WITH FASTFIX ONLY

Sheets can be fixed with Fastfix fixing at 300mm centres to all framing for walls and ceilings (refer Figure 12). This method is a fully visible mechanical fixing method when adhesive fixing is not suitable. This detail is only suitable for walls in dry areas and ceilings in wet or dry areas.

Figure 12: HardieGlaze Lining fast fix fixing method

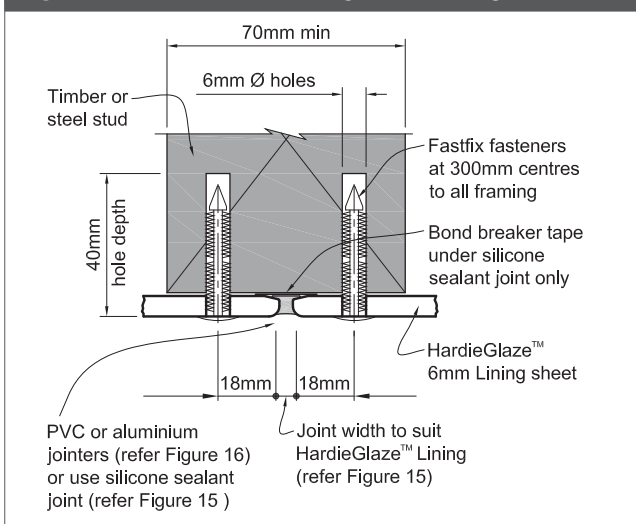

6.10 RAISED-HEAD SCREW-FIXING METHOD

6mm HardieGlaze Lining can be fixed with raised-head screws at 300mm centres to all framing (refer Figure 13). This method can be used when removable panels are required. This detail is only suitable for walls in dry areas and ceilings in wet or dry areas.

Figure 13: HardieGlaze Lining sealing strip screw method

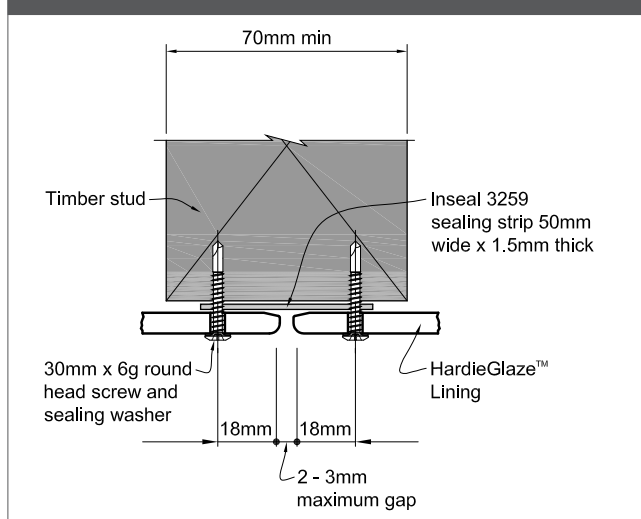

6.11 CERAMIC TILE INSERTS

Ceramic tile inserts can be placed in the 6mm HardieGlaze Lining to give contrast. Refer to Figure 14 for the tile insert detail. Inserts must be above the level of the shower rose (refer Figure 6).

Figure 14: Ceramic tile inserts into HardieGlaze Tile and Premium Lining detail

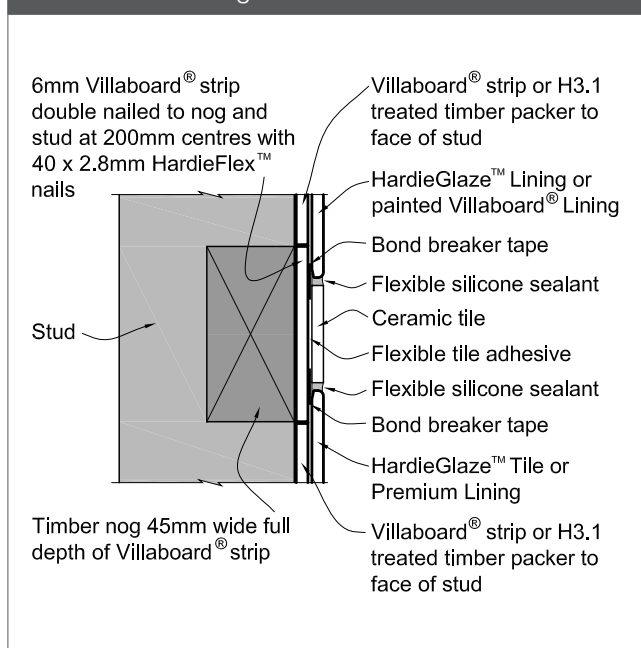

7 Jointing

7.1 SILICONE JOINTING PROCEDURES

This method of jointing applies to 6mm HardieGlaze Lining only which has factory radiused edges.

- Fix bondbreaker tape to the framing behind the joints before fixing sheets (refer Figure 15).
- Peel back the protective film from the sheet edge.
- Ensure the sheet edge is prepared for a silicone joint. The factory-painted, radiused sheet edge should be used for all flat joints. (refer Figure 15).
- For an internal corner place the site cut edges sand papered and well primed into corner first, then place factory finished edge 3-4mm from the face of the first sheet.
- Once the sheet edge is prepared, fit the first sheet on one side of the joint, fix a spacer in position at 300mm centres approximately, but do not nail fully in. Place the next sheet on the wall and firmly push onto the spacer to give the correct gap for the silicone joint (refer Figure 15).
- Temporarily brace the edges and centre of the sheet as required. Allow adhesive to be fully cured (as per manufacturer's instructions).

Accurately mask each side of the joint with the recommended masking tape. Refer Table 5. Incorrect tapes can cause coating removal.

- Prime the joint to be silicone sealed according to the manufacturer's instructions.
- Apply the silicone sealant, neatly finish and remove the masking tape only when all sealant operations are complete and whilst sealant is still wet.
- Do not touch silicone sealant with bare fingers as this can encourage mould growth. Use a plastic spoon, wear rubber gloves or cover finger with a plastic bag.

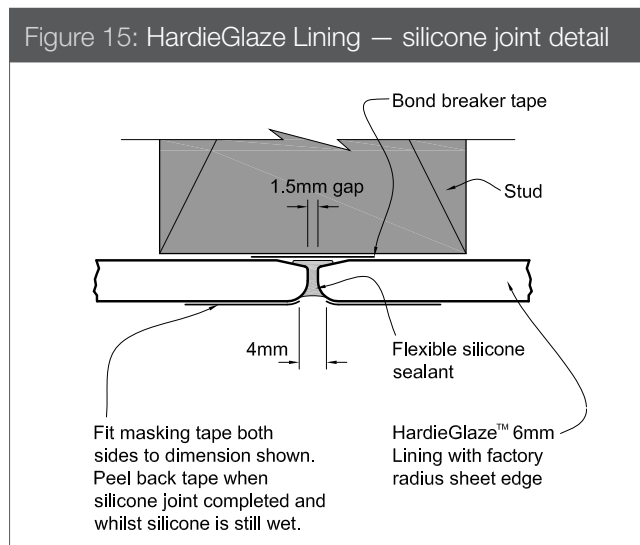

7.2 DRY AREA WALL JOINTS

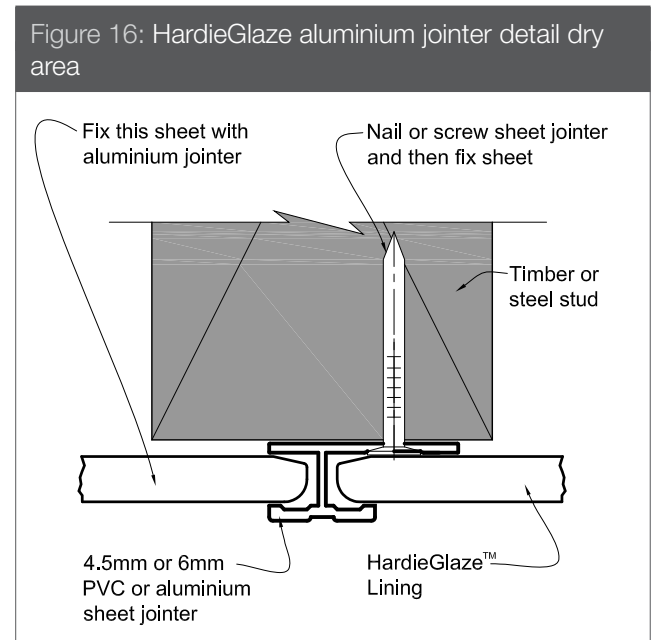

When using a cap mould, cut the vertical jointer shorter to suit.

Silicone joint detail as per Figure 15 is also suitable for dry area lining applications.

7.3 WET AREA WALL JOINTS

When the PVC or aluminium jointer method is used for wet area applications, ensure that all the sheet edges have been sealed into jointers with a silicone sealant (refer Figure 17).

When using a cap mould, cut the vertical jointer shorter to suit.

Fix mouldings at max 300 centres with nail or screw.

Around baths and showers:

- Around baths silicone detail to be used.
- For a stainless-steel shower installation it is essential that a drip edge is formed at the bottom of the sheet (refer Figure 21).

Penetrations:

- Seal all fittings and penetrations through HardieGlaze Lining with a silicone or similar sealant. Use flanges/face plates to cover the penetrations.
- Ensure that adequate moisture management is achieved for the details not covered in this manual. Refer to designer for the details.

Figure 17: HardieGlaze PVC or aluminium jointer detail

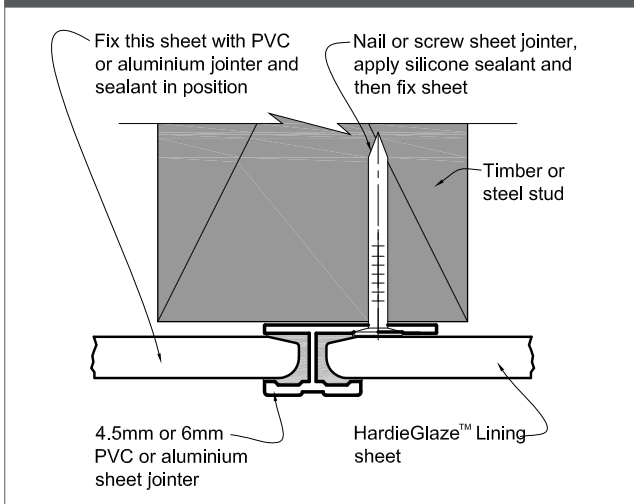

Note: For showers and similar wet areas the PVC or aluminium jointer must be silicone-sealant filled. External and internal corners and cap moulds must also be silicone filled in these wet areas.

7.4 EXTERNAL CORNER JOINTS

For 6mm HardieGlaze Lining there are two external jointing options:

- the external corner mould (refer page 6).
- silicone joint the radius edges. Ensure the entire radius edge is painted prior to silicone jointing.

For 4.5mm HardieGlaze Lining use the external corner mould (refer page 5).

7.5 INTERNAL CORNER JOINTS

For 6mm HardieGlaze Lining there are three internal jointing options:

- the flexible-edge 2-piece internal corner mould
- the internal corner mould (refer page 6).
- silicone joint — when a site cut sheet edge is used to form a corner, ensure the cut edge butts into the corner framing and the manufactured edge forms a gap to finish the silicone joint.

For 4.5mm HardieGlaze Lining use the internal corner mould (refer page 5).

7.6 WALL-TO-CEILING JOINTS

Use either a timber moulding, PVC or aluminium cap. Refer to Figure 18 for details.

Figure 18: HardieGlaze Lining ceiling scotia moulding alternatives

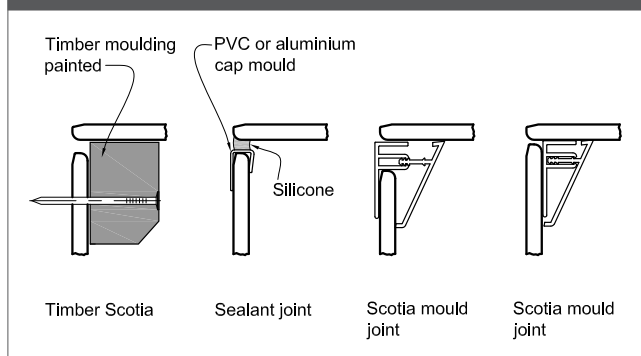

7.7 WET AREA WALL-TO-FLOOR JOINTS

For details of HardieGlaze Lining junction with a tiled floor, refer to Figure 22. For details of HardieGlaze Lining junction with a vinyl covered floor, refer to Figure 23.

Figure 19: HardieGlaze PVC bath/acrylic shower flashing detail

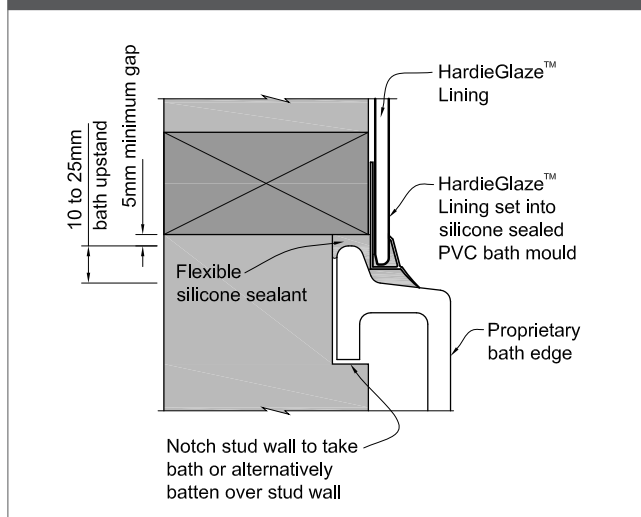

Note: Seal bottom edge and 100mm up back of sheet with Dulux Primercryl, Dulux Acraprime 501/1 or similar.

Figure 20: HardieGlaze Lining sealant bath/acrylic shower detail

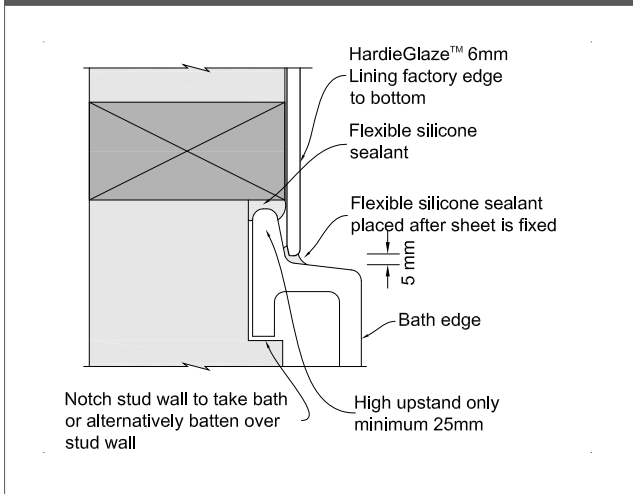

Notes:

1. This detail is suitable for high-upstand baths only.
2. Seal bottom edge and 100mm up back of sheet with Dulux Primercryl, Dulux Acraprime 501/1 or similar.
3. High-upstand acrylic shower bases can be finished to a similar detail.

Figure 21: HardieGlaze Lining shower drip edge detail

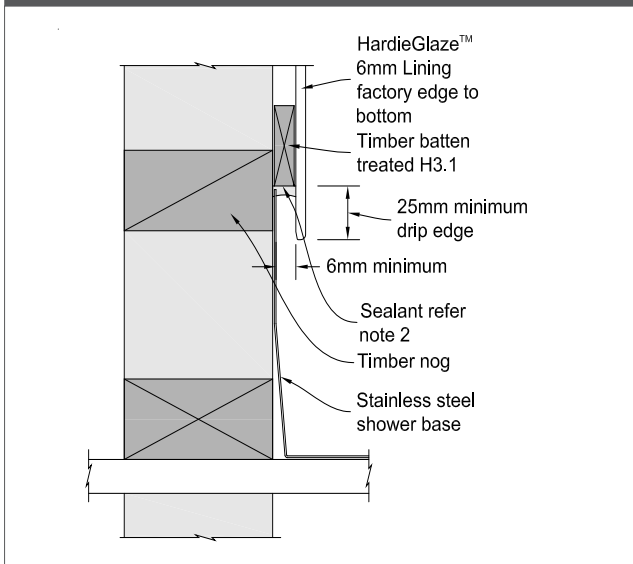

Notes:

1. The bottom edge and 100mm up the back face must be sealed with Dulux Primercryl, Dulux Acraprime 501/1 or similar.
2. It is important to use sealant here to prevent possible damage to the framing.
3. The shower tray can be notched into the stud to eliminate battening.

Figure 22: HardieGlaze Lining wall to tiled floor detail

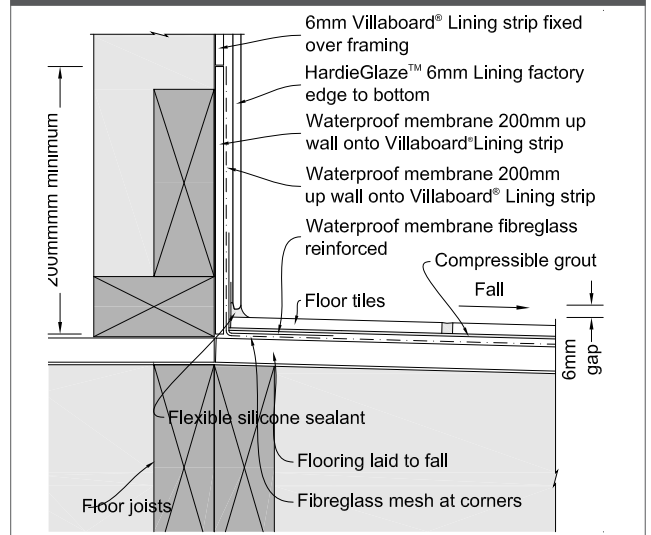

Notes:

1. HardiePanel™ Compressed floor to be laid with two directional falls to corner waste. Perimeter edge of waste hole must be a minimum of 50mm from edge of sheet or wall. Build up falls around waste hole before applying waterproof membrane.
2. Tiles to be laid prior to HardieGlaze Lining installation.
3. Seal bottom edge and 100mm up back of sheet with Dulux Primercryl, Dulux Acraprime 501/1 or similar.

Figure 23: HardieGlaze Lining wall to tiled floor and upstand detail

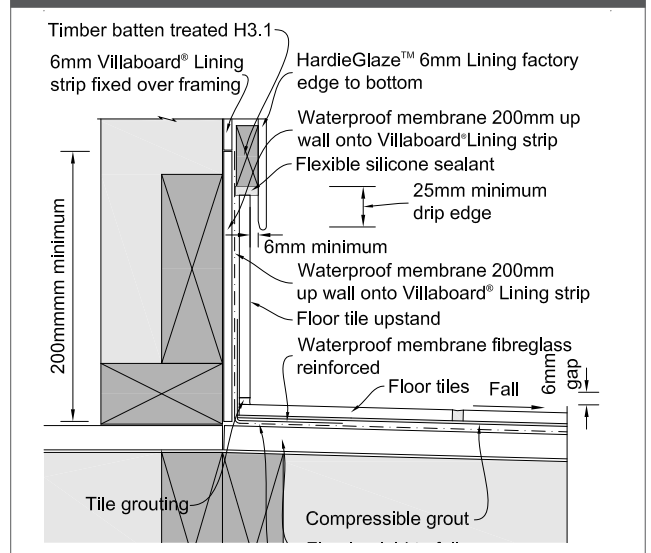

Notes:

1. HardiePanel™ Compressed floor to be laid with two directional falls to corner waste. Perimeter edge of waste hole must be a minimum of 50mm from edge of sheet or wall. Build up falls around waste hole before applying waterproof membrane.
2. Tiles to be laid prior to HardieGlaze Lining installation.
3. Seal bottom edge and 100mm up back of sheet with Dulux Primercryl, Dulux Acraprime 501/1 or similar.

8 Special applications

Figure 24: HardieGlaze Lining to covered vinyl floor detail

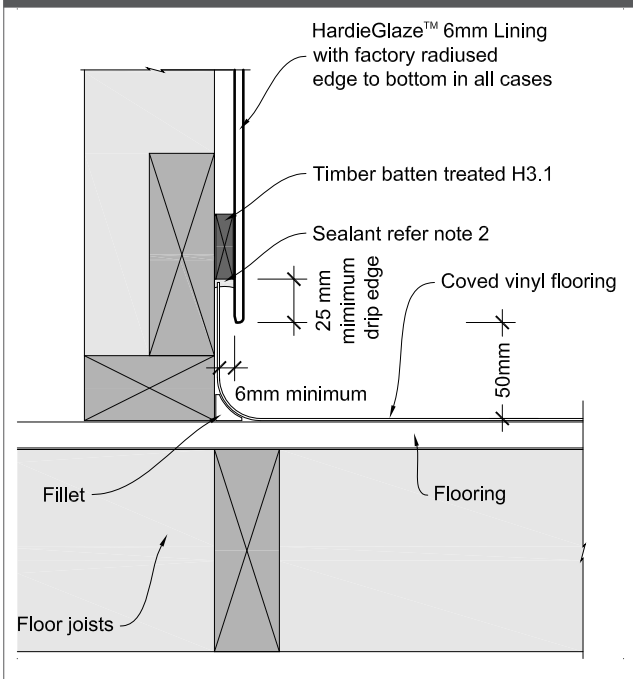

Sealant notes:

1. Cut edges must be site sealed with Dulux Primercryl, Dulux Acraprime 501/1 or similar before sealant is applied.
2. Silicone seal the joint. For full application instructions refer to the sealant manufacturer. Suitable sealants are listed in Table 5.
3. The silicone joint is suitable only for radiused-edge sheets — HardieGlaze Tile and Premium Lining. Do not touch silicone with a bare finger.

8.1 INDOOR SWIMMING POOL APPLICATION

A chlorine environment is not suitable for wallboard adhesives therefore when using HardieGlaze Lining in areas such as indoor swimming pool areas, check with the adhesive manufacturer regarding their suitability in this application or use stainless steel screws with cup washers. It is recommended that a higher level of timber treatment is used for timber framing in this environment and back of sheets must be fully sealed.

HardieGlaze Lining must be cleaned more frequently when used in a chlorine environment.

8.2 SPLASHBACK

HardieGlaze Lining can be used as a splashback. Minimum clearance of 200mm must be maintained from the closest outer ring of hob.

8.3 WET AREA PENETRATION

Figure 25: Wet wall caddy

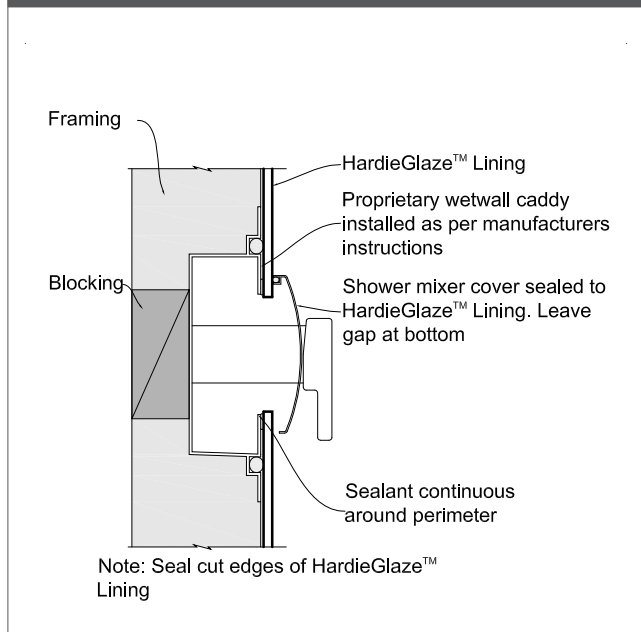

9 Product information

9.1 PRODUCT DESCRIPTION

HardieGlaze Lining is a pre-finished wall and ceiling lining for use in wet, semi-wet and dry areas.

HardieGlaze Lining is manufactured by James Hardie. The base sheets are a light grey colour. All sheets have the face side fully sanded to give a smooth finish, and are polyurethane coated. HardieGlaze Lining is also back sealed. The name 6.0 Base Sheet or 4.5 Base Sheet is printed across the back of all sheets at regular intervals. Additional identification is the name written on the sticker applied to back of lining. HardieGlaze Lining is for interior use only. It must not be used for external applications. The unique radiused, painted edge of HardieGlaze Tile and Premium Lining sheets mean they can be silicone jointed (refer Figures 15 and 16).

HardieGlaze Lining is manufactured to AS/NZS 2908.2 'Cellulose-Cement Products Part 2: Flat Sheets' (ISO 8336 'Fibre Cement Flat Sheets') standards in New Zealand. James Hardie New Zealand is an ISO 9001 'Telarc' certified manufacturer. HardieGlaze Lining is classified Type B, Category 3 in accordance with AS/NZ 2908.2 'Cellulose-Cement Products'.

For Safety Data Sheets (SDS) visit www.jameshardie.co.nz or Ask James Hardie on 0800 808 868.

9.2 PRODUCT APPLICATION

HardieGlaze Lining is a prefinished wall and ceiling lining suitable for the applications described in Table 6.

9.3 DURABILITY

Although HardieGlaze Lining is resistant to moisture, the product specification must be designed, installed and maintained to resist the penetration of moisture. HardieGlaze Lining installed as per this installation manual complies with 15 year durability requirement of the NZBC.

HardieGlaze Lining has demonstrated resistance to permanent moisture induced deterioration (rotting) by passing the following tests in accordance with AS/NZS 2908.2:

- Water permeability (Clause 8.2.2)
- Warm water (Clause 8.2.4)
- Heat rain (Clause 6.5)
- Soak dry (Clause 8.2.5)

9.4 SHEET PROPERTIES

The HardieGlaze Lining base sheet is:

- Extremely durable and will not rot or decay even under prolonged exposure to moisture and steam, provided the sheet edges are well sealed by the sealant or jointer method and regular drying cycles occur.
- Stable within the normal range of moisture and temperature changes. Regular drying cycles occur.
- Soft impact resistance.
- Non combustible material.

- Suitable for use in fire exitways.
- Easily cut and fixed.
- Contains silica (refer to Safe Working Practices pages 8 and 9).

The polyurethane coating is:

- Hard wearing and resistant to light scratching.
- Machine applied and requires minimum maintenance under normal conditions of use.
- Easy to clean.
- HardieGlaze Lining does not support mould growth. HardieGlaze Lining is ideal in conditions where there is moisture. However, wetting of the back of the sheet must be avoided as this will degrade the support framing and may eventually lead to the deterioration of HardieGlaze Lining.

9.5 SHEET MOISTURE CONTENT AND MASS

HardieGlaze Lining sheets vary in moisture content with the seasons. The approximate mass of HardieGlaze Lining sheets at equilibrium moisture content is:

4.5mm – 7kg/m²

6mm – 9.5kg/m²

9.6 FIRE PROPERTIES

Maximum service temperature for the HardieGlaze Lining is 60°C.

HardieGlaze Lining sheet has been tested for heat release rate as per AS/NZS 3837 and the product has a Heat Release Rate below 50 kw/m².

HardieGlaze Lining has a 'Group Number' classification of 1-S as per the requirements of clause C of the NZBC.

10 Maintenance

10.1 GENERAL

HardieGlaze Lining is resistant to the damage from moisture, but still the sheet must be installed and maintained to resist the penetration of moisture. It is important that the sealants and jointers are prevented from any damage to ensure that water doesn't penetrate behind HardieGlaze Lining.

Regular inspections are required to determine whether any system components need replacing. Refer to cleaning recommendation in clause 10.2.

10.2 CLEANING PROCEDURES

Always use a non abrasive soft cloth to clean the sheet surface. Non-abrasive cleaning detergents can be used if needed.

Product Warranty

April 2014

James Hardie New Zealand ("James Hardie") warrants to the first purchaser of the Product for a period of 15 years from the date of purchase that the HardieGlaze™ Lining (the "Product"), will be free from defects due to defective factory workmanship or materials and, subject to compliance with the conditions below, will be resistant to cracking, rotting, fire and damage from termite attacks to the extent set out in James Hardie's relevant published literature current at the time of installation. James Hardie warrants for a period of 15 years from the date of purchase that the accessories supplied by James Hardie to be used in conjunction with the Product will be free from defects due to defective factory workmanship or materials.

Nothing in this document shall exclude or modify any legal rights a customer may have under the Consumer Guarantees Act or otherwise which cannot be excluded or modified at law.

CONDITIONS OF WARRANTY:

The warranty is strictly subject to the following conditions:

- a) James Hardie will not be liable for breach of warranty unless the claimant provides proof of purchase and makes a written claim either within 30 days after the defect would have become reasonably apparent or, if the defect was reasonably apparent prior to installation, then the claim must be made prior to installation;
- b) this warranty is not transferable;
- c) the Product must be installed and maintained strictly in accordance with the relevant James Hardie literature current at the time of installation and must be installed in conjunction with the components or products specified in the literature. To obtain copies of such literature please contact 'Ask James Hardie™ 0800 808 868'. Further, all other products, including coating and jointing systems, applied to or used in conjunction with the Product must be applied or installed and maintained strictly in accordance with the relevant manufacturer's instructions and good trade practice;
- d) the project must be designed and constructed in strict compliance with all relevant provisions of the current New Zealand Building Code ("NZBC"), regulations and standards;
- e) the claimant's sole remedy for breach of warranty is (at James Hardie's option) that James Hardie will either supply replacement product, rectify the affected product or pay for the cost of the replacement or rectification of the affected product;
- f) James Hardie will not be liable for any losses or damages (whether direct or indirect) including property damage or personal injury, consequential loss, economic loss or loss of profits, arising in contract or negligence or howsoever arising. Without limiting the foregoing James Hardie will not be liable for any claims, damages or defects arising from or in any way attributable to poor workmanship, poor design or detailing, settlement or structural movement and/or movement of materials to which the Product is attached, incorrect design of the structure, acts of God including but not limited to earthquakes, cyclones, floods or other severe weather conditions or unusual climatic conditions, efflorescence or performance of paint/coatings applied to the Product, normal wear and tear, growth of mould, mildew, fungi, bacteria, or any organism on any Product surface or Product (whether on the exposed or unexposed surfaces);
- g) all warranties, conditions, liabilities and obligations other than those specified in this warranty are excluded to the fullest extent allowed by law;
- h) if meeting a claim under this warranty involves re-coating of Products, there may be slight colour differences between the original and replacement Products due to the effects of weathering and variations in materials over time.

Disclaimer: The recommendations in James Hardie's literature are based on good building practice, but are not an exhaustive statement of all relevant information and are subject to conditions (c), (d), (f) and (g) above. James Hardie has tested the performance of HardieGlaze™ Lining when installed in accordance with the HardieGlaze™ Lining installation manual, in accordance with the standards and verification methods required by the NZBC and those test results demonstrate the product complies with the performance criteria established by the NZBC. However, as the successful performance of the relevant system depends on numerous factors outside the control of James Hardie (e.g. quality of workmanship and design) James Hardie shall not be liable for the recommendations made in its literature and the performance of the relevant system, including its suitability for any purpose or ability to satisfy the relevant provisions of the NZBC, regulations and standards, as it is the responsibility of the building designer to ensure that the details and recommendations provided in the relevant James Hardie installation manual are suitable for the intended project and that specific design is conducted where appropriate.

Copyright April 2014. © James Hardie New Zealand. TM and ® denotes a Trademark or Registered Mark owned by James Hardie Technology Limited.



Ask James Hardie™

Call 0800 808 868

www.jameshardie.co.nz