

WAGNER

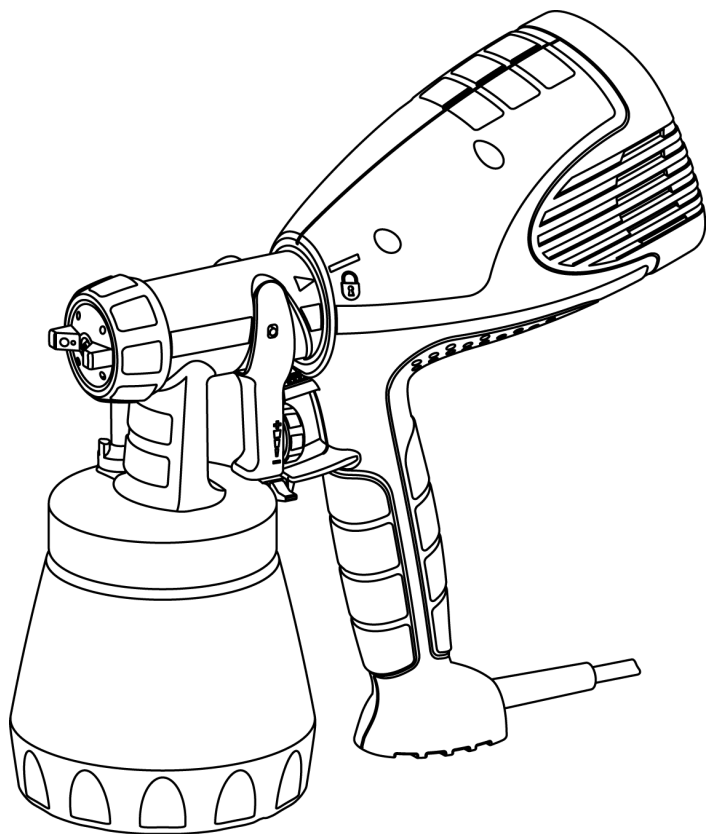

2 Jahre
Garantie

2 years
Guarantee

2 ans de
garantie

2 jaar
garantie



W 550
D/GB/F/NL



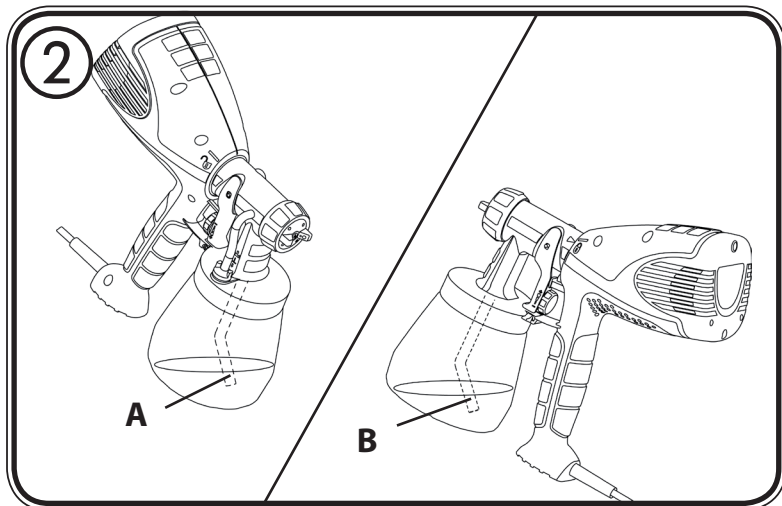
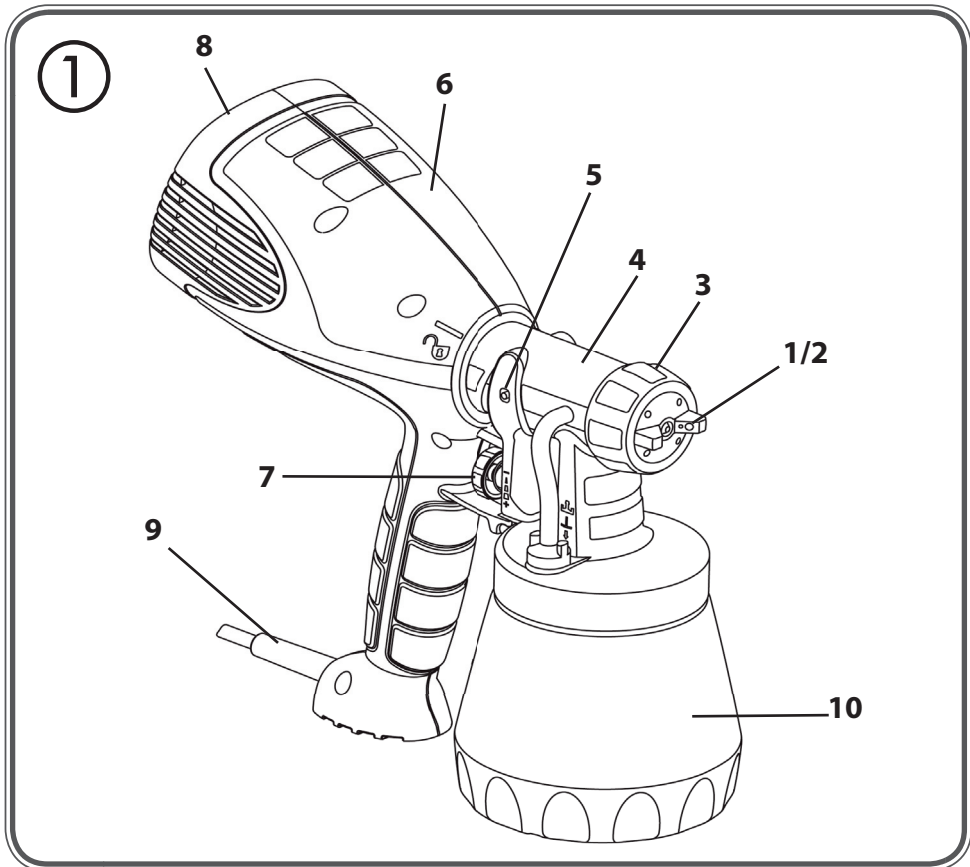

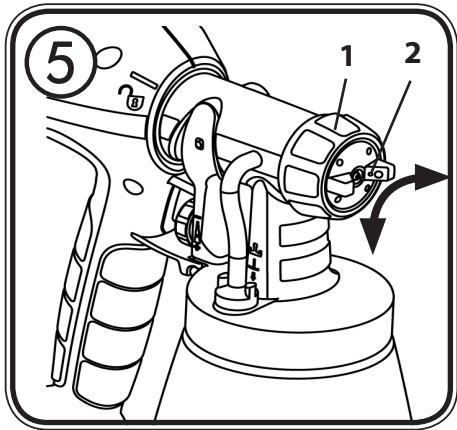
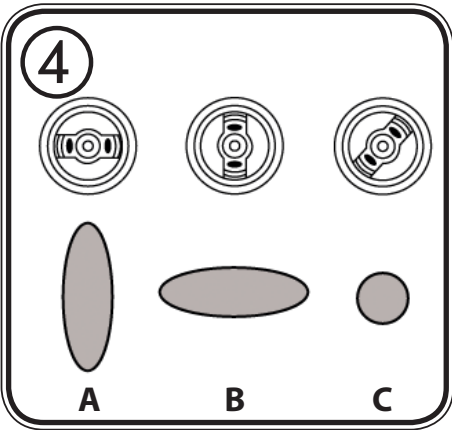
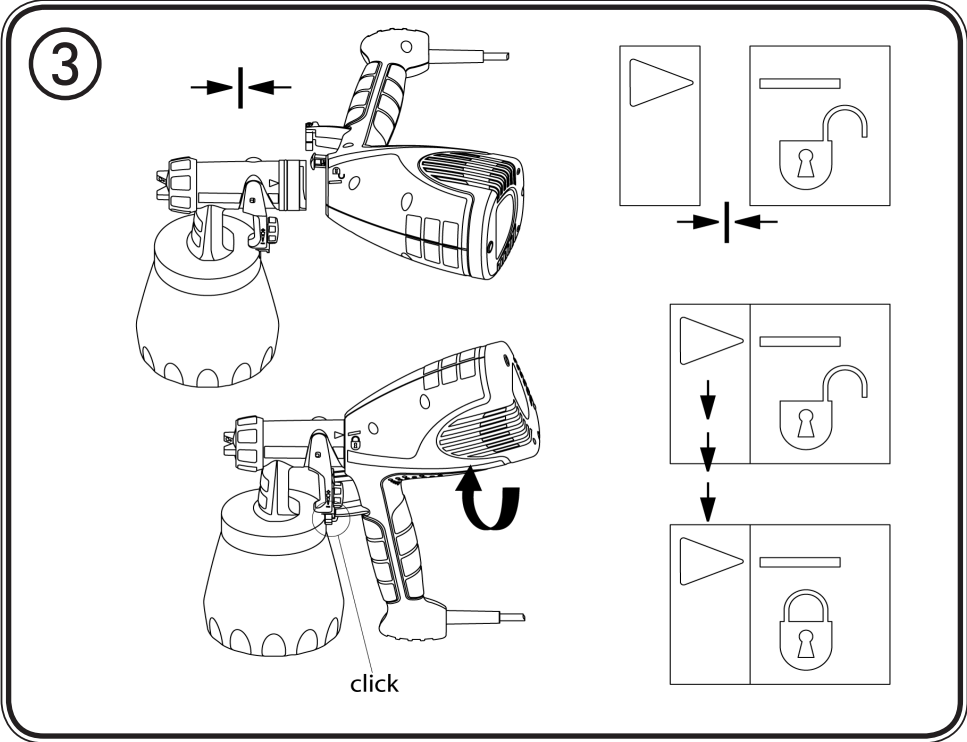

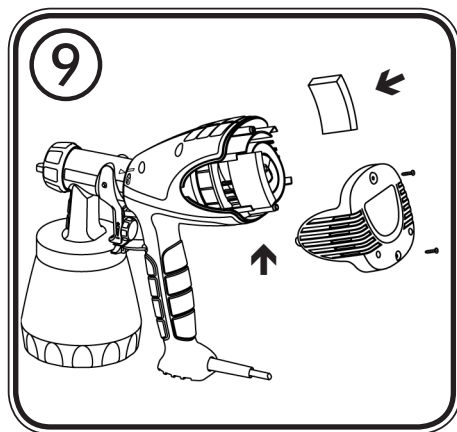
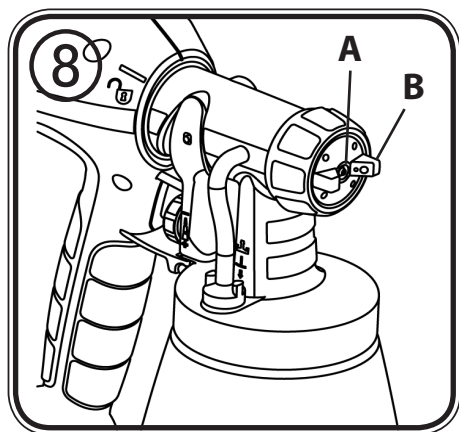
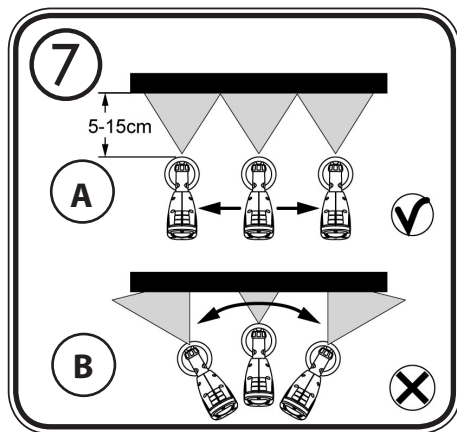
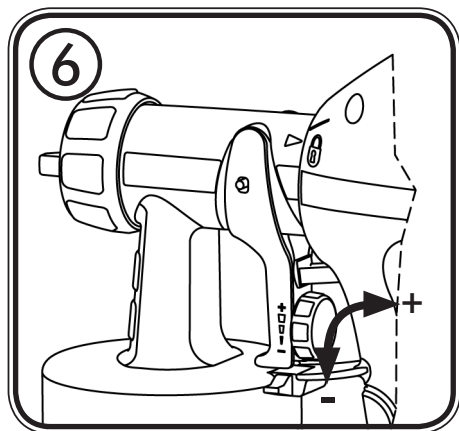

10

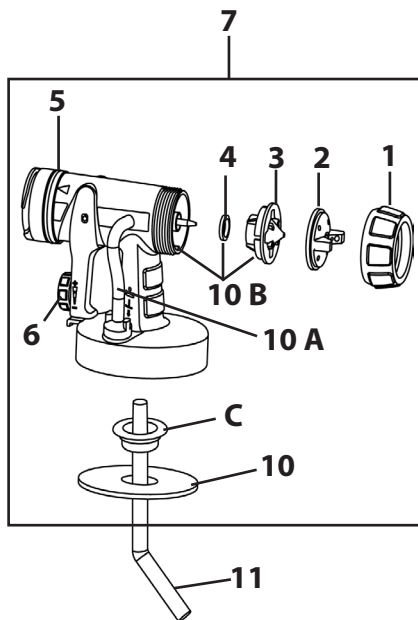
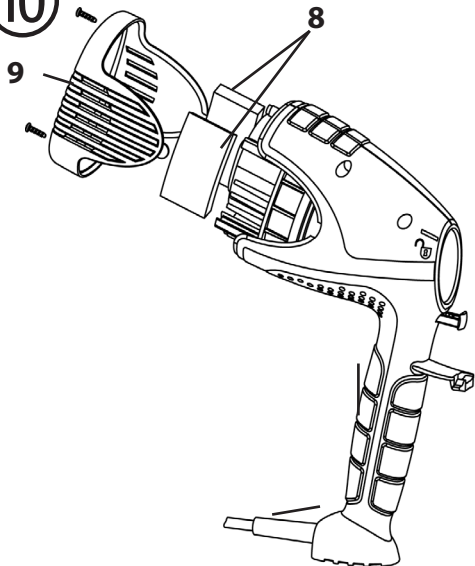

10A

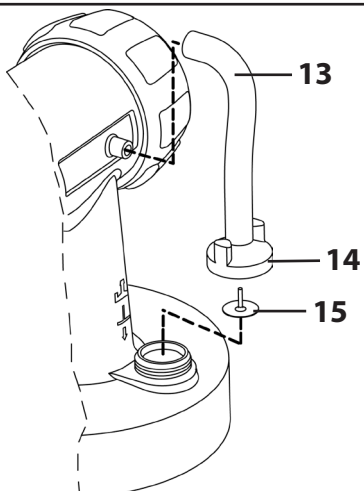

10B

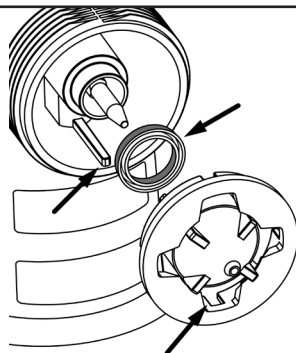

1 - 10

11 - 20

21 - 30

31 - 40



.....41 - 42

Operating instruction

Read the operating instructions carefully before using the tool and observe the safety instructions. Keep the operating instructions in a safe place.

General Safety Instructions

Caution!



Read all the instructions. *Non-observance of the instructions below can cause electric shock, fire and or serious personal injuries. The term "power tool" used below covers both mains-operated power tools (with mains lead) and accumulator-operated power tools (without mains lead).*

1. Workplace

- a) **Keep your workplace clean and tidy.** *Untidiness and unlit working areas can lead to accidents.*
- b) **Never use the tool in hazardous areas that contain flammable liquids, gases or dusts.** *Power tools generate sparks that can ignite the dust or vapors.*
- c) **Keep children and other persons away when using the power tool.** *You can lose control of the tool if you are distracted.*

2. Electrical Safety

- a) **The tool plug must fit into the socket. The plug may not be modified in any form. Do not use adaptor plugs together with protective-earthed tools.** *Unmodified plugs and suitable sockets reduce the risk of an electric shock.*
- b) **Avoid physical contact with earthed surfaces such as pipes, heating elements, stoves and refrigerators.** *The risk through electric shock increases if your body is earthed.*
- c) **Keep the equipment away from rain and moisture.** *The risk of an electric shock increases if water penetrates electrical equipment.*
- d) **Do not misuse the mains lead by carrying the tool by the lead, hanging it from the lead or by pulling on the lead to remove the plug. Keep the lead away from heat, oil, sharp edges or moving tool parts.** *Damaged or twisted leads increase the risk of an electric shock.*
- e) **If you work outdoors, use only extension leads that are approved for outdoor use.** *The use of an extension lead that is suitable for outdoors reduces the risk of an electric shock.*

3. Safety of Persons

- a) **Be attentive. Pay attention to what you are doing and work sensibly with a power tool. Do not use the tool if you are tired or under the influence of drugs, alcohol or medication.** *Just a moment of inattentiveness while using the tool can lead to serious injuries.*
- b) **Wear personal safety equipment and always wear safety goggles** *Wearing*

personal protective equipment, such as dust mask, non-slip safety shoes, safety helm or ear protection, depending on the type of power tools, reduces the risk of injury.

- c) Avoid accidental starting-up. Ensure that the switch is in the "OFF" position before inserting the plug into the socket.** *Accidents can occur if you carry the power tool while your finger is on the switch or if you connect the power tool to the power supply which it is on.*
- d) Remove setting tools or wrenches before switching on the power tool.** *A tool or wrench that is in a rotating tool part can lead to injuries.*
- e) Do not overestimate your abilities. Ensure that you are standing securely and have your balance at all times.** *This ensures that you can control the tool better in unexpected situations.*
- f) Wear suitable clothing. Do not wear wide clothing or jewelry. Keep your hair, clothes and gloves away from moving parts.** *Loose clothing, jewelry or long hair can be caught in moving parts.*
- g) This appliance is not intended for use by persons (including children) with reduced physical, sensory or mental capabilities, or lack of experience and knowledge, unless they have been given supervision or instruction concerning use of the appliance by a person responsible for their safety.** *Children should be supervised to ensure that they do not play with the appliance.*

4. Careful Handling and Use of Power Tools

- a) Do not overload the tool. Use the power tool designed for the work that you are doing.** *You work better and safer in the specified performance range if you use the suitable power tool.*
- b) Do not use power tools whose switch is defective.** *A power tool that cannot be switched on or off is dangerous and has to be repaired.*
- c) Remove the plug from the socket before carrying out tool settings, changing accessories or putting the tool away.** *This precautionary measure prevents unintentional starting of the tool.*
- d) Store unused power tools so that they are inaccessible to children. Do not let persons use the tool who are not familiar with it or who have not read these instructions.** *Power tools are dangerous when they are used by inexperienced persons.*
- e) Take proper care of your tools. Check whether the moving parts function trouble-free and do not jam, whether parts are broken or damaged so that the tool function is impaired. Have damaged parts repaired before using the tool.** *Many accidents have their origin in power tools that have been maintained badly.*
- f) Use the power tool, accessories, insert tools, etc. in accordance with these instructions and in a fashion specified for this special tool type. Take the working conditions and the activity to be carried out into consideration.** *The use of power tools for purposes other than the intended ones can lead to dangerous situations.*

5. Service

- a) **Have your tool repaired only by qualified specialist personnel and only with original spare parts.** *This ensures that the tool safety is maintained.*
- b) **If the supply cord is damaged, it must be replaced by the manufacturer or its service agent or a similarly qualified person in order to avoid a safety hazard.**

Safety Instructions for Spray Guns

- You may only spray coating materials such as paints, varnishes, glazes, etc. with a flashpoint of 21°C (32°C in UK) and higher without additional warning. (German classification of coating material is hazard classes A II and A III, see material tin.)
- The device may not be used in workplaces covered by the explosion-protection regulations.
- There must be no sources of ignition such as, for example, open fires, smoke of lit cigarettes, cigars and tobacco pipes, sparks, glowing wires, hot surfaces, etc. in the vicinity during spraying.
- Do not spray any substances whose hazard potential is not known.
- Before working on the spray gun remove the power plug from the socket.
- Do not use the spray guns to spray flammable substances.
- The spray guns are not to be cleaned with flammable solvents which have a flashpoint under 21°C.
- Caution against dangers that can arise from the sprayed substance and observe the text and information on the containers or the specifications given by the substance manufacturer.

Recommendation: Wear a breathing mask and safety glasses when spraying.



CAUTION - DANGER OF INJURY!

Never point the spray gun at yourself, at other people or at animals.

- When working with the W 550 indoors as well as outdoors ensure that no solvent vapors are sucked in by the spray gun.
- When working outdoors, be aware of the wind direction. Wind can carry the coating substance across greater distances - thus causing damage. When working indoors, provide for adequate ventilation.
- Do not let children handle the device.
- Never open the device yourself in order to carry out repairs in the electrical system!
- The units may only be used with a functional valve. **If paints rises in the ventilating hose (Fig. 1, item 11) do not operate the unit further!** Dismantle and clean the ventilating hose, valve and diaphragm and replace the diaphragm if necessary.
- **Do not lay the spray gun.**

With original WAGNER accessories and spare parts, you have the guarantee that all safety regulations are fulfilled.

Technical Data

Max. viscosity	90 DIN-s
Power source	230 - 240 V~
Power consumption	280 W
Atomizing output:	65 W
Double insulation	
Sound pressure level	74 dB (A)
Oscillation level	< 2,5 m/s ²
Weight	1,3 kg

TechnDat_GB

Description (Abb. 1)

1) Air Cap	2) Nozzle
3) Union nut	4) Spray gun front part
5) Trigger guard	6) Spray gun rear part
7) Material volume adjustment	8) Air filter cover
9) Mains lead	10) Container
11) Ventilating hose	12) Valve

Beschreibung_GB

Coating Materials Suitable for Use

Water- and solvent-based paints, finishes, primers, 2-component paints, clear finishes, automotive finishes, staining sealers and wood sealer-preservatives.

Coating Materials Not Suitable for Use

Wall paints (emulsion paints) etc., alkali and acidic paints. Coating materials with a flash point below 21°C.

Preparation of the Coating Material

The enclosed spray attachment can be used to spray paints, varnishes and glazes that are undiluted or slightly diluted. Detailed information is available in the technical data sheet of the manufacturer (→ Internet download).

1. Stir the material up and put the required amount into the paint container.

Thinning recommendation

Sprayed material	
Glazes	undiluted
Wood preservatives, mordants, oils, disinfection agents, plant protective agents	undiluted
Paints containing solvents and water-soluble paints, primers, vehicle coating paints, thick-film glazes	dilute by 5 - 10%

Visko

2. If the convey capacity is too low, add 5 - 10% dilution step-by-step until the convey capacity fulfils your requirements.

Start-up

Before connecting to the mains supply, be sure that the supply voltage is identical with the value given on the rating plate.

- Unscrew the container from the spray gun.
- Aligning suction tube. (Fig. 2)
If the suction tube is positioned correctly, the container contents can be sprayed without almost any residue.
When working on lying objects: Turn the suction tube forwards. (Fig. 2 A)
Spraying work when working on overhead objects: Turn the suction tube rearwards. (Fig. 2 B)
- Set the container on a sheet of paper, pour in the prepared coating material and screw the container tightly onto the spray gun.
- Connect the front part with the rear part of the gun (Fig. 3).
- Put the machine down only on a level, clean surface. Otherwise the machine could tip over!
- Pull the trigger guard. The W 550 has a two-stage trigger guard. In the first stage the turbine is started. If the trigger guard is pressed further, the material is transported.
- Adjust the spray setting on the spray gun.

Three different spray jet settings can be chosen on the spray gun, depending on the application and target object.

Selecting the Spray Setting

Fig. 4 A = horizontal flat jet → for horizontal surfaces

Fig. 4 B = vertical flat jet → for vertical surfaces

Fig. 4 C = circular jet → for corners, edges and hard-to-reach surfaces

Adjusting the desired Spray Setting (Fig. 5)

With the union nut (2) slightly unscrewed, turn the air cap (1) to the desired spraysetting position (arrow). Then tighten the union nut.



WARNING!

Danger of injury! Never pull the trigger guard while adjusting the air cap.

Adjusting the Material Volume (Fig. 6)

Set the material volume by turning the regulator on the trigger guard of the spray gun.

- turn to the left → lower material volume

+ turn to the right → higher material volume

Spray Technique

- The spray result depends heavily on the smoothness and cleanliness of the surface to be sprayed. Therefore the surface should be carefully prepared and kept free of dust.
- Cover all surfaces not to be sprayed.
- Cover screw threads or similar parts of the target object.
- It is advisable to test the spray gun on cardboard or a similar surface to find the correct setting.

Important: Begin spraying outside of the target area and avoid interruptions inside the target area.

- **Correct (Fig. 7a)** Be sure to hold the spray gun at an even distance of approx. 5 - 15 cm to the target object.
- **Incorrect (Fig. 7b)** Heavy spray fog build-up, uneven surface quality.
- Move the spray gun evenly cross-wise or up-and-down, depending on the spray pattern setting.
- An even movement of the spray gun results in an even surface quality.
- When coating material builds up on the nozzle (A) and air cap (B) (Fig. 8), clean both parts with a solvent or water.

Interruption of Work till 4 Hours

- Turn the machine off.
- When processing 2-component varnishes, clean the device immediately.

Taking Out of Operation and Cleaning

Proper cleaning is the prerequisite for problem-free operation of the paint application device. No warranty claims are accepted in case of improper or no cleaning.

- 1) Unplug the power plug. Vent the container in case of longer breaks and after the work has been terminated. This can be done by briefly turning open and then closing the container or by pulling the trigger guard and letting the paint into the original paint container.
- 2) Divide the spray gun. Press the hook (Fig. 3 b "click") slightly downwards. Turn the gun front part and gun rear part against each other.
- 3) Unscrew the container. Empty any remaining coating material back into the material tin.
- 4) Preclean the container and suction tube with a brush. Clean the ventilating bore (Fig. 10, C).
- 5) Pour solvent or water into the container. Screw the container back on. **Use only solvents with a flashpoint over 21°C .**
- 6) Assemble the gun again (Fig. 3).
- 7) Insert the power plug, turn on the machine and spray the solvent or water into a container or a cloth.
- 8) Repeat the above procedure until the solvent or water emerging from the nozzle is clear.
- 9) Turn off the machine and remove the plug.
- 10) Screw of the container and empty it. Pull out the suction tube with container seal.

CAUTION! Never clean seals, diaphragm and nozzle or air holes of the spray gun with metal objects.
The ventilation hose and diaphragm are only solvent-resistant to a limited extent. Do not immerse in solvent, only wipe.

11) Pull the ventilating hose (Fig. 10 A, 13) at the top from the gun body. Screw off the valve cover (14). Remove the diaphragm (15). Clean all the parts carefully.



WARNING!

Never hold the spray gun rear part under water or immerse it into liquids. Clean the housing only with a moistened cloth.

12) Clean the outside of the spray gun and container with a cloth soaked in solvent or water.

13) Unscrew the union nut and remove the air cap and nozzle. Clean the air cap and nozzle with a brush and solvent or water.

Assembly

The unit may only be operated with an integer diaphragm (Fig. 10 A, 15). Place the diaphragm with the pin facing upwards on the bottom section of the valve. Also see the marking on the gun body. Place on the valve cover and screw it closed. Place the ventilating hose on the valve cover and on the nipple at the gun body.

Slide the nozzle seal (Item 4) with the groove (slot) facing forwards into the nozzle (Fig. 10 B). Put the nozzle onto the gun body and find the correct position by turning it. Put the air cap onto the nozzle and tighten it using the union nut.

Place the container seal from below on the suction tube and slide it over the collar, while turning the container seal slightly. Insert the suction tube with container seal in the gun body.

Maintenance

- Change the air filter if it is soiled (Fig. 9). The smooth side of the air filter must be placed towards the machine.



WARNING! Never operate the machine without the air filter; dirt could be sucked in and interfere with the function of the machine.

- **In order to mount the gun more easily apply lubricating grease (enclosed) liberally to the O-ring at the gun front part. (Fig. 10, Item 5)**

Accessories

An additional container with a top makes changing colours easy. The top prevents the paint from drying out and the evaporation of solvents.

Spare Parts List (Fig. 10)

Pos.	Designation	Order No.
1	Union nut	0417 319
2	Air cap	0414 368
3	Nozzle	0417 349
4	Nozzle seal	0417 706
5	O-ring	0417 308
6	Material volume regulation with spring, complete	0417 910
7	Spray gun front part complete incl. 800 ml container	0417 914
8	Air filter set	0417 912
9	Air filter cover	0417 303
10	Container seal	0417 358
11	Suction tube	0417 357
12	Container with cover	0413 909
13	Ventilating hose	2304 027
14	Valve cover	
15	Diaphragm	
17	Lubricating grease	9892 550

Ersatz GB

The new **CLICK&PAINT SYSTEM** with additional spray attachments and accessories offers the right tool for each work.



We recommend against using the W 550 with the WallPerfect spray attachment.

Accessories (not included in the delivery)

Name	Order No.
Container with cover 800 ml Ensures that the paint does not dry out and the solvent does not evaporate.	0413 909
Brilliant spray attachment incl. 600 ml container Optimised nozzle and air guidance for brilliant paint results	0417 932
Perfect Spray spray attachment incl. 800 ml. conainer For a rapid paint change. For medium- and large-scale objects and furniture.	0417 914
Small-scale spray attachment incl. 250 ml container For filigree objects, detailed and creative work.	0417 918
Perfect Spray spray attachment incl. 1400 ml container Rapid working at larger objects such as timber houses, garage doors, etc.	0417 917
Detail / Radiator spray attachment incl. 600 ml container For inaccessible places, such as radiators, cupboard corners, recesses etc.	0417 915

Further information about the WAGNER range of products for renovating is available under www.wagner-group.com

Correction of Malfunctions

Problem	Cause	Remedy
No coating material emerges from the nozzle	Nozzle clogged Feed tube clogged Material volume setting turned too far to the left (-) Feed tube loose No pressure build-up in container	Clean Clean Turn to the right (+) Insert Tighten container
Coating material drips from the nozzle	Nozzle loose Nozzle worn Nozzle seal worn Coating material assembly at air cap, nozzle or needle	Tighten Change Change Clean
Atomisation too coarse	Viscosity of coating material too high Material volume too large Material volume adjusting screw turned too far to the right (+) Nozzle contaminated Air filter heavily soiled Too little pressure build-up in container	Thin Turn material volume adjusting screw to the left (-) Clean Change Tighten container
Spray jet pulsates	Coating material in container running out Air filter heavily soiled	Refill Change
Coating material causes "paint tears"	Too much coating material applied.	Turn material volume adjusting screw to the left (-)
Too much fog of coating material (Overspray)	Distance to the object too large Too much coating material applied	Reduce distance Turn material volume adjusting screw to the left (-)
Paint in the ventilating hose	Diaphragm soiled Diaphragm defective	Clean the diaphragm Replace the diaphragm

Stör GB

Environmental protection



The appliance and accessories should be recycled in an environmentally friendly way. Do not dispose of the appliance with household waste. Support environmental protection by taking the appliance to a local collection point or obtain information from a specialist retailer.

Important Note regarding Product Liability!

Due to an EC ordinance in effect since 01.01.1990, the manufacturer is liable for his product only if all parts originate from or were approved by the manufacturer and the devices are assembled and operated correctly. The use of other accessories and spare parts can partially or completely invalidate the liability.

Warning

If the supply cord of this appliance is damaged, it must only be replaced by a repair shop appointed by the manufacturer, because special purpose tools are required.

Warning: Do not connect the blue or brown wire to the earth terminal of the plug! The wires in this mains lead are coloured in accordance with the following code:

blue = neutral **brown** = live

As the colours of the wires in the mains lead of this appliance may not correspond with the coloured markings identifying the terminals in your plug, proceed as follows:

◆ Should the moulded plug have to be replaced, never re-use the defective plug or attempt to plug it into a different 13 A socket. This could result in an electric shock.

◆ Should it be necessary to exchange the fuse in the plug only use fuses approved by ASTA in accordance with BS 1362. 5 Amp fuses may be used.

◆ To ensure that the fuse and fuse carrier are correctly mounted please observe the provided markings or colour coding in the plug.

◆ After changing the fuse, always make sure that the fuse carrier is correctly inserted. With out the fuse carrier, it is not permissible to use the plug.

◆ The correct fuses and fuse carriers are available from your local electrical supplies stockist.

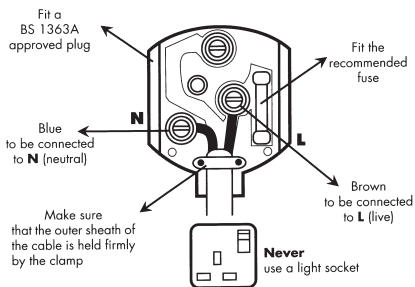

2 years guarantee

The guarantee runs for two years, counting from the date of sale (sales slip). It covers and is restricted to free-of-charge rectification of faults which are demonstrably attributable to the use of faulty materials in manufacture, or assembly errors; or free-of-charge replacement of the defective parts. The guarantee does not cover incorrect use or commissioning or fitting or repair work which is not stated in our operating instructions. Wearing parts are also excluded from the guarantee. The guarantee excludes commercial use. We expressly reserve the right to fulfil the guarantee. The guarantee expires if the tool is opened up by persons other than WAGNER service personnel. Transport damage, maintenance work and loss and damage due to faulty maintenance work are not covered by the guarantee. Under any guarantee claim, there must be proof of purchase of the tool through submission of the original receipt. Wherever legally possible, we exclude all liability for injury, damage or consequential loss, especially if the tool has been used for a purpose other than that stated in the operating instructions, commissioned or repaired other than in accordance with our operating instructions or if repairs are performed by someone who is unqualified. We reserve the right to perform any repairs in excess of those stated in our operating instructions. In case of guarantee or repair, please refer to your point of sale.

D CE Konformitätserklärung

Wir erklären in alleiniger Verantwortung, dass dieses Produkt den folgenden einschlägigen Bestimmungen entspricht:

98/37/EG, 2006/95/EG; 2004/108/EG; 2002/95/EG; 2002/96/EG

Angewandte harmonisierte Normen:

EN 61000-3-2:2006; EN 61000-3-3:1995+A1:2001+A2:2005; EN 55014-1:2006;

EN 55014-2:1997+A1:2001; EN 50366:2003+A1:2006;

EN 50144-1:1998+A1:2002+A2:2003; EN 50144-2-7:2000

GB CE Declaration of Conformity

We declare under sole responsibility that this product conforms to the following relevant stipulations: 98/37/EG, 2006/95/EG; 2004/108/EG; 2002/95/EG; 2002/96/EG
Applied harmonised norms:

EN 61000-3-2:2006; EN 61000-3-3:1995+A1:2001+A2:2005; EN 55014-1:2006;

EN 55014-2:1997+A1:2001; EN 50366:2003+A1:2006;

EN 50144-1:1998+A1:2002+A2:2003; EN 50144-2-7:2000

F CE Déclaration de conformité

Nous déclarons sous notre responsabilité que ce produit est en conformité avec les réglementations suivantes:

98/37/EG, 2006/95/EG; 2004/108/EG; 2002/95/EG; 2002/96/EG

Conforme aux normes et documents normalisés:

EN 61000-3-2:2006; EN 61000-3-3:1995+A1:2001+A2:2005; EN 55014-1:2006;

EN 55014-2:1997+A1:2001; EN 50366:2003+A1:2006;

EN 50144-1:1998+A1:2002+A2:2003; EN 50144-2-7:2000

NL CE Conformiteitsverklaring

Wij verklaren dat dit product voldoet aan de volgende normen:

98/37/EG, 2006/95/EG; 2004/108/EG; 2002/95/EG; 2002/96/EG

En normatieve documenten:

EN 61000-3-2:2006; EN 61000-3-3:1995+A1:2001+A2:2005; EN 55014-1:2006;

EN 55014-2:1997+A1:2001; EN 50366:2003+A1:2006;

EN 50144-1:1998+A1:2002+A2:2003; EN 50144-2-7:2000

WAGNER

J. Wagner GmbH
Otto-Lilienthal-Str. 18
D-88677 Markdorf



W. van der Hoeven
Managing Director



i. V. J. Ulbrich
Development Manager

D **J. Wagner GmbH**
Otto-Lilienthal-Str. 18
D-88677 Markdorf
☎ Hotline 0180/1000 227
☎ +49/75 44/505-169

B **Wagner Spraytech Belgie**
Veilinglaan 58
1861 Meise-Wolvertem
☎ +32/2/2 69 46 75 ☎ +32/2/2 69 78 45

F **Wagner France S.a.r.l.**
Parc Gutenberg - Bâtiment F
8 voie la Cardon
91128 Palaiseau Cedex
☎ 0 825 011 111 ☎ 0169 81 72 57

DK/S **Wagner Spraytech Scandinavia A/S**
Helgeshøj Allé 28
DK-2630 Tåstrup
☎ +45/43 27 18 18 ☎ +45/43 43 05 28

CH **J. Wagner AG**
Industriestraße 22
9450 Altstätten
☎ +41/71/7 57 22 11 ☎ +41/71/7 57 23 23

SK **Phobos Corporation Spol.ro**
Stanicka 6, 92700 Sala
Slowakei
☎ +421/31/7 70 78 84 ☎ +421/31/7 70 22 42

NL **Wagner Spraytech Benelux B.V.**
Zoonebaan 10
3542 EC Utrecht
☎ +31/30/2 41 41 55 ☎ +31/30/2 41 17 87

GB **Wagner Spraytech (UK) Ltd.**
The Coach House
2 Main Road
Middleton Cheney OX17 2ND
☎ UK-Helpline 0844 335 0517
5 p per minute (landline)

CZ **M.A.T Ltd.**
Na Roudne 176
301 62 Plzen
☎ +420 376 709 205 ☎ +420 376 709 263

E **J. Wagner Spraytech Ibérica S.A.**
Ctra. N-340, Km 1245,4
08750 Molins de Rei (Barcelona)
☎ +34/93/6 80 00 28 ☎ +34/93/6 68 01 56

SLO Adresa servisa:
GMA Elektromehanika d.o.o.
Cesta Andreja Bitenca 115,
Ljubljana 1000/Slowenien
☎ +386(1)/583 83 04 ☎ +386(1)/518 38 03

H Magyarországi szerviz
Hondimpex KFT.
Kossuth L. u. 48-50
8060 Mór
☎ +36(-22)/407 321 ☎ +36(-22)/407 852

PL **PUT Wagner Service**
ul. E. Imieli 14
41-605 Swietochlowice
☎ +48/32/2 45 06 19 ☎ +48/32/2 41 42 51

HR Adresa servisa:
EL-ME-HO
Horvatinčićev put 2
10436 Rakov Potok/Kroatien
☎/☎ +385(-1)65 86 - 028

AUS **Wagner Spraytech Australia Pty. Ltd.,**
14-16 Kevlar Close,
Braeside, VIC 3195/Australien
☎ +61/3/95 87 20 00 ☎ +61/3/95 80 91 20

www.wagner-group.com

Irrtümer und Änderungen vorbehalten.
Not responsible for errors and changes.
Sous réserves d'erreurs et de modifications.
Fouten en wijzigingen voorbehouden.