

Absco Space Saver Shed Assembly Instructions Model: 15081SK

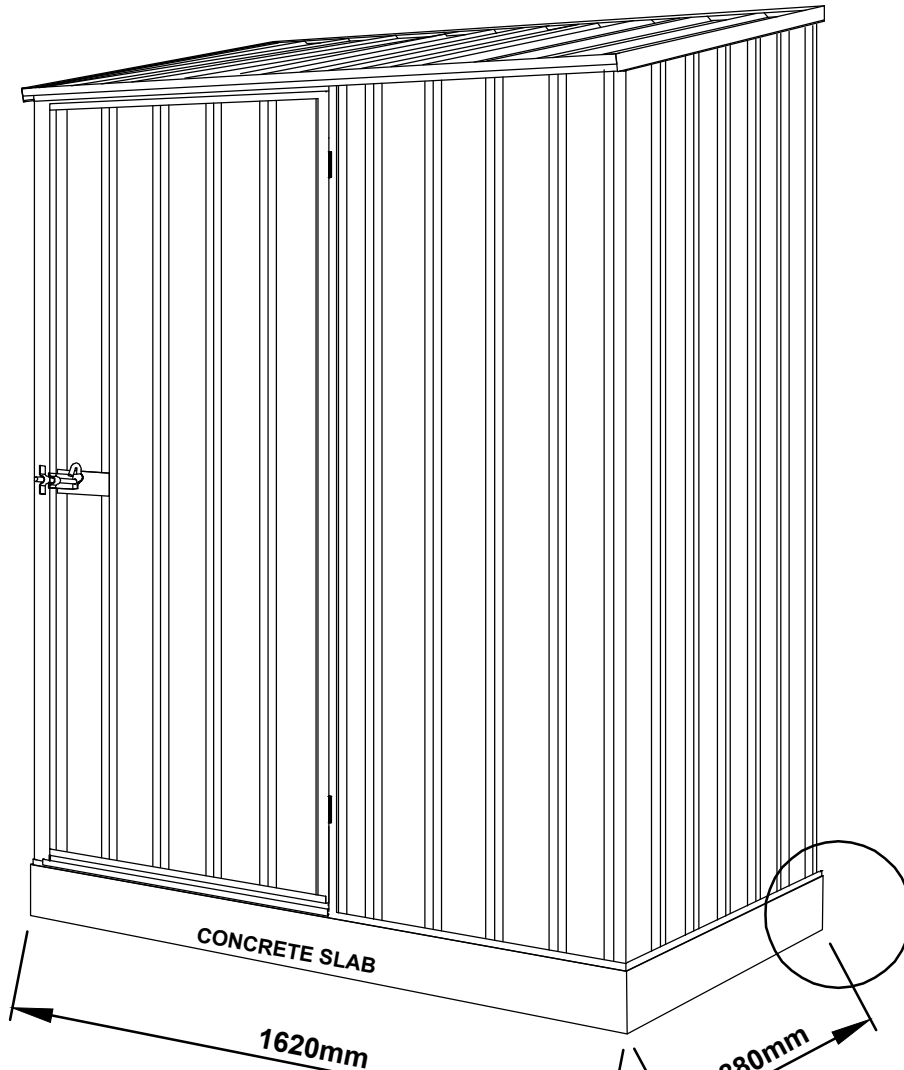

**FRONT BASE
LENGTH: 1.52m**

**SIDE BASE
LENGTH: 0.78m**

**FRONT WALL
HEIGHT: 1.8m**

**REAR WALL
HEIGHT: 1.95m**



Quality
ISO 9001



WHEN LAYING YOUR CONCRETE
SLAB, ENSURE THERE IS A
REBATED EDGE 25mm DEEP
AROUND THE PERIMETER

THIS WILL HELP WATER EGRESS
FROM THE BASE OF THE SHED

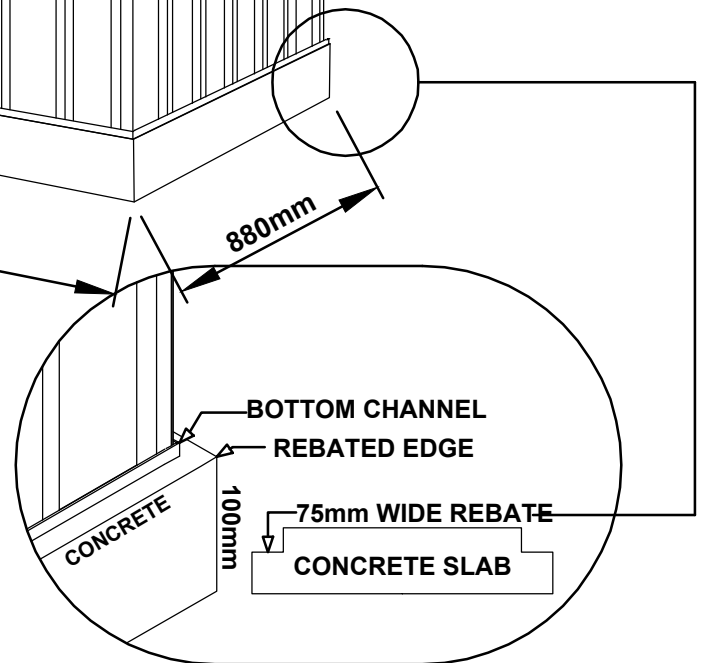

We thank you for choosing an Australian made shed. For further assistance please visit our detailed instructional video library at [Http://www.absco.sheds.com.au/watch-videos](http://www.absco.sheds.com.au/watch-videos)

At ABSCO Industries we are always looking to be number ONE, so please let us know what you think of our instructions. Feedback makes us better.
feedback@absco.com.au



Available on the
App Store

★★★★★
SHED ASSEMBLY APP

GET IT ON
Google Play



GENERAL INSTRUCTIONS

- Before commencing any assembly, read through these instructions in detail to gain a thorough understanding of assembly methods and associated details.
- Unpack the carton and carefully identify and check off all the parts against the parts described and illustrated on pages three and four.

SITE PREPARATION

- The site for the shed must be level. An uneven surface may result in misalignment of parts.
- It is recommended that the shed be set on a 100mm concrete slab and anchored down appropriately (refer to last page for details).
- Anchor sets are not supplied as standard items with this product as some customers wish to use their own anchoring systems.

TOOLS REQUIRED



Normal: 4mm & 10mm
Masonry: 10mm

OPTIONAL





A NOTE ON SAFETY

- Some parts may have sharp edges. It is advisable to wear gloves when handling these items and safety glasses if drilling holes. Sensible shoes are highly recommended.
- Do not erect your shed in windy conditions, ensure that the shed is securely anchored to a solid foundation immediately after construction is completed.
- It is highly recommended to erect the shed with two or more people.





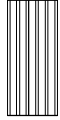
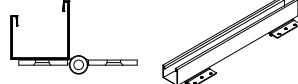
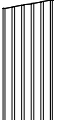
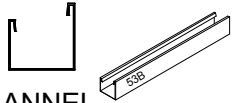
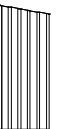
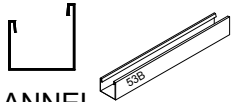
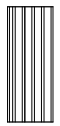
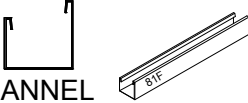
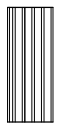
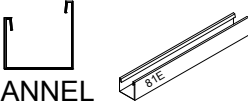
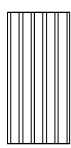
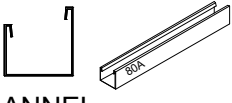
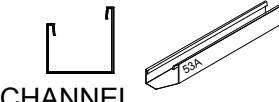
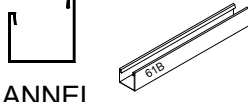
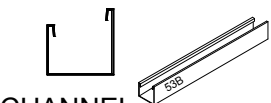

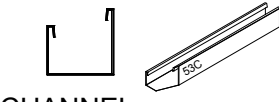
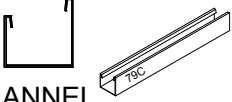

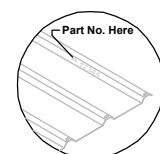

COMPONENTS PACKING LIST - CHECK OFF ALL COMPONENTS

QTY	COMPONENT DESCRIPTION	PART No.	CHECK	QTY	COMPONENT DESCRIPTION	PART No.	CHECK
2	 STEEL SHEET 1915 X 773mm	43B		1	 CHANNEL WITH HINGES L = 1725mm	58A	
1	 STEEL SHEET 1915mm X 773mm	X4L		1	 CHANNEL L = 1725mm	58B	
1	 STEEL SHEET 1915mm X 773mm	X2R		2	 CHANNEL L = 773mm	58C	
2	 STEEL SHEET 865mm X 773mm	43D		1	 CHANNEL L = 1513mm	81F	
1	 STEEL SHEET 1785mm X 711mm	34A		2	 CHANNEL L = 1513mm	81E	
1	 STEEL SHEET 1725mm X 773mm	B		1	 CHANNEL L = 1785mm	80A	
1	 CHANNEL L = 1513mm	53A		2	 CHANNEL L = 786mm	61B	
1	 CHANNEL L = 1513mm	53B		2	 CHANNEL L = 773mm	81J	
1	 CHANNEL L = 1513mm	53C		1	 CHANNEL L = 783mm	79C	

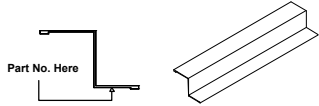
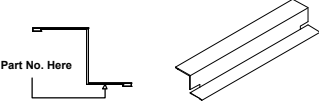
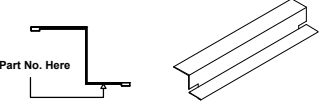
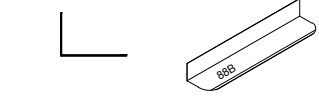
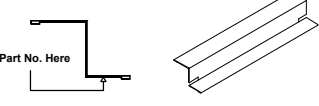
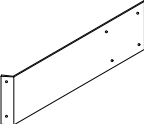
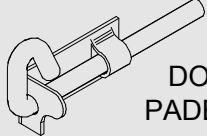
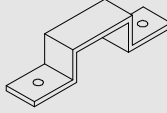
**ALL SHEETS HAVE PART NO.S LOCATED ON
LOWER RIGHT OR UPPER LEFT CORNER OF
COLORED SIDE AS SHOWN**





COMPONENTS PACKING LIST - (CONT.) CHECK OFF ALL COMPONENTS

QTY	COMPONENT DESCRIPTION	PART No.	CHECK	QTY	COMPONENT DESCRIPTION	PART No.	CHECK
1	 Part No. Here JAMB L= 1785mm	89A		2	 Part No. Here JAMB L= 1120mm	91A	
1	 Part No. Here JAMB L= 1785mm	89B		2	 LIP TRIM L= 865mm	88B	
1	 Part No. Here JAMB L= 783mm	90C					
FITTINGS & ACCESSORIES PACKET CONTENTS							
1	 DOOR STRAP L: 165mm	12A		1	ASSEMBLY INSTRUCTIONS		
1	PSTKSGL SINGLE DOOR FITTINGS PACK						
PSTKSGL - SINGLE DOOR FITTINGS PACK							
1	 DOOR PADBOLT	FAST006		1	 DOOR PADBOLT HASP	FAST007	
1	3mm DRILL BIT 	DRILL		1	 PHILLIPS DRIVER BIT	FAST038	
1	 SELF TAPPING SCREWS PACKET CONTAINING 220			1	PACK 6P SCREW PACK 6		
PACK 6P - SCREW PACK 6							
6	 3/16 COUNTERSUNK SCREWS & NUTS			6	 3.2 x 8mm BLIND POP RIVETS		

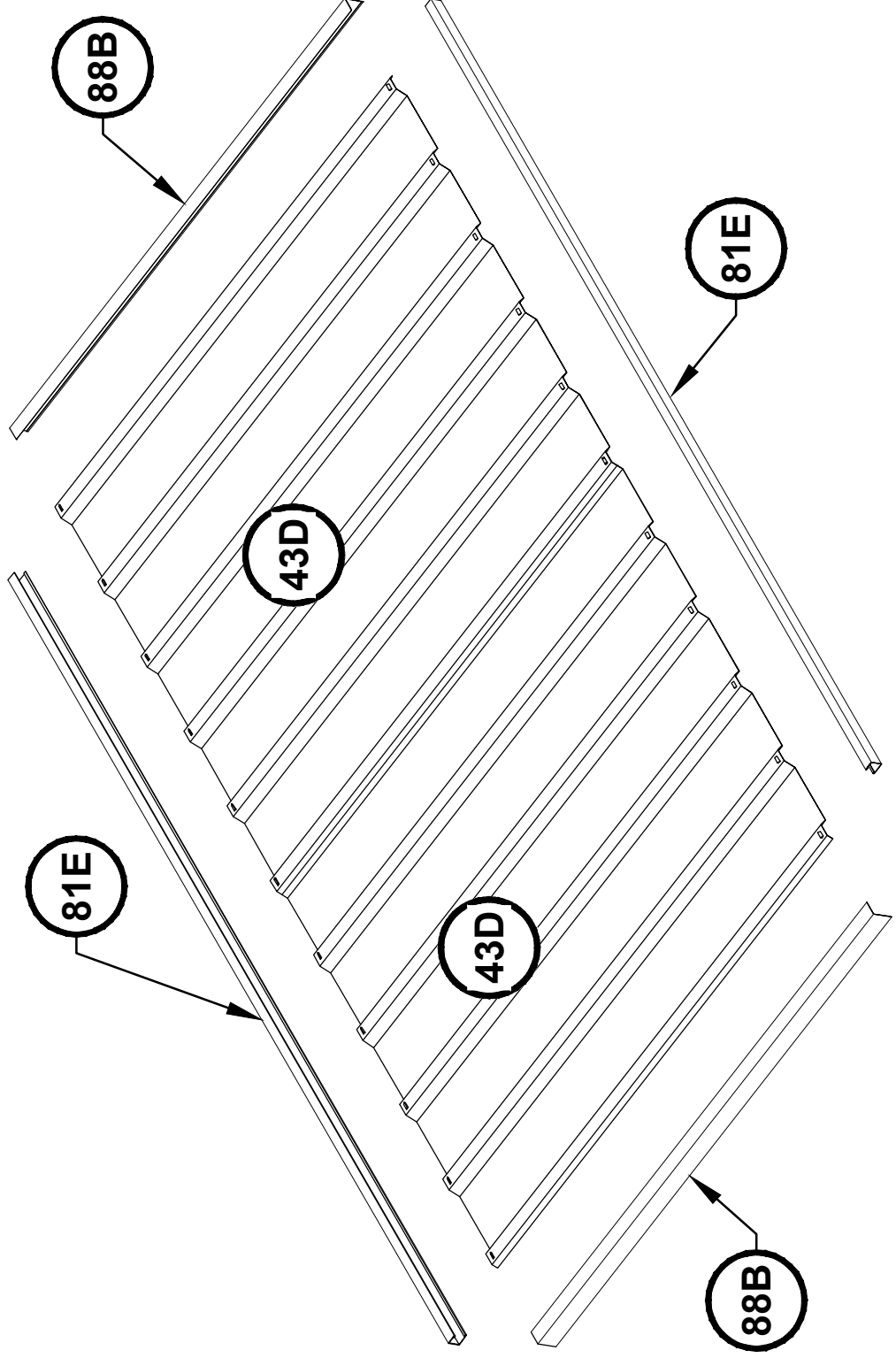

VIEW OF ROOF COMPONENTS

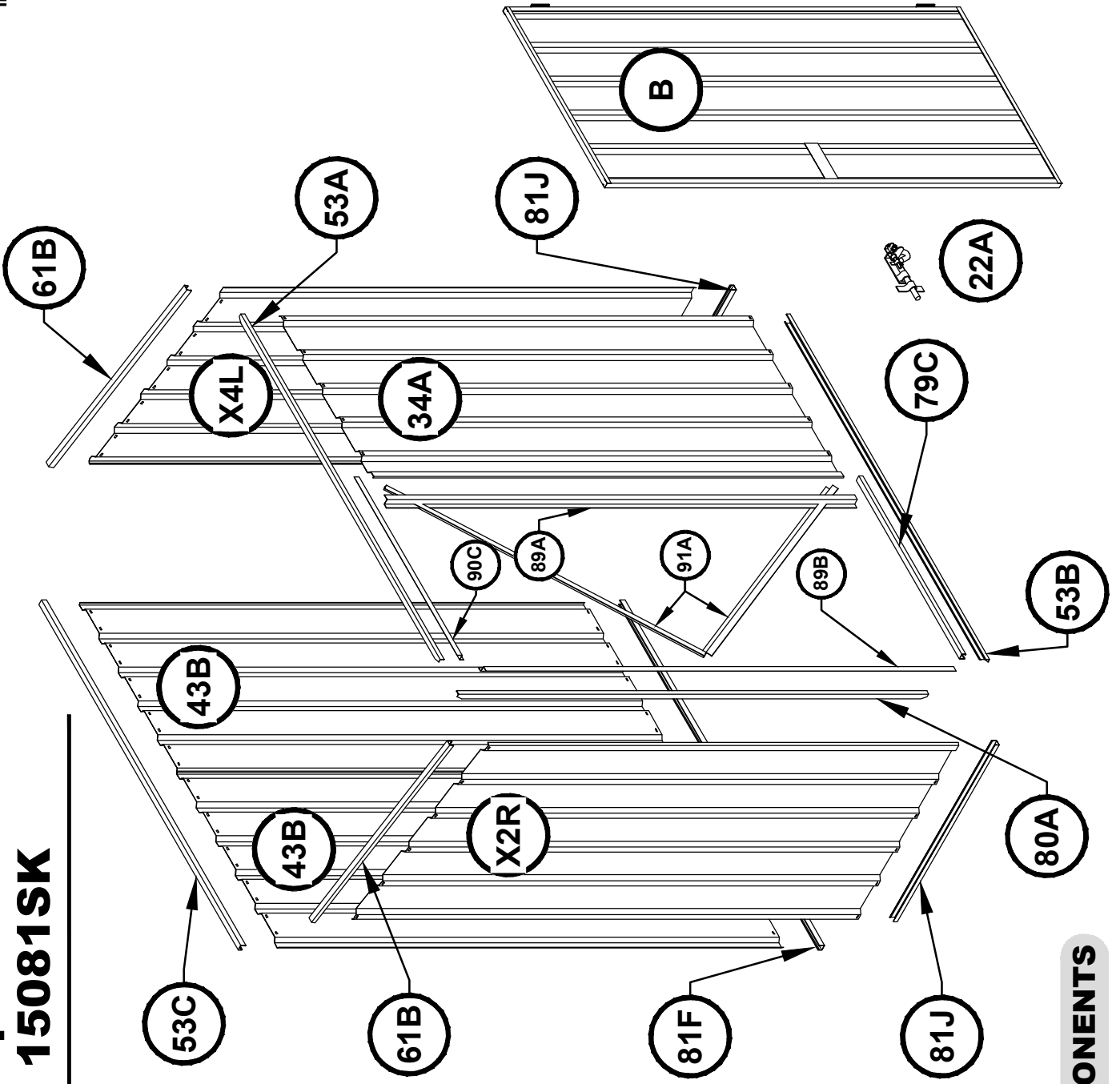



VIEW OF WALL COMPONENTS



ABSCO ASSEMBLY INTRODUCTION

The snaptite assembly system locks most perimeter channels to all roof and wall sheets without the need for tools and fasteners.

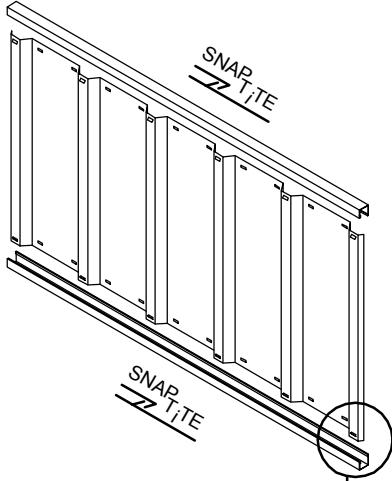

To pre-assemble the four wall panels and two roof panels, the perimeter channels are secured to the top and bottom of each panel using the snaptite system, as detailed on the following pages wherever you see the symbol.

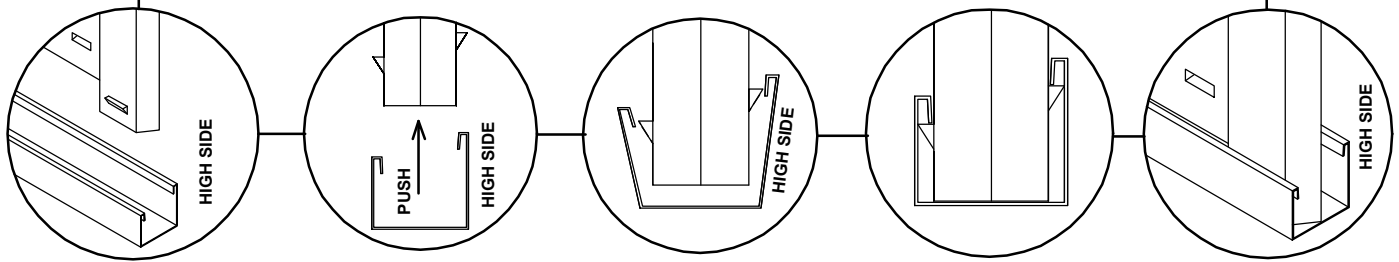
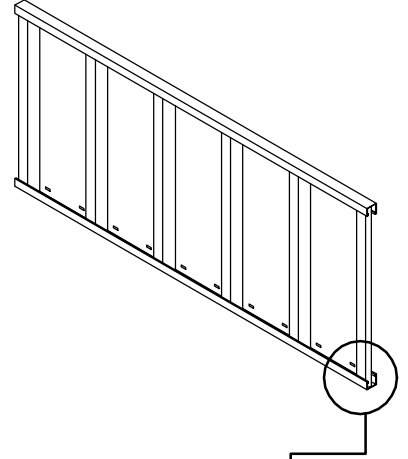

After joining sheets together, position channel over one end of the sheets, gently tapping it over the snaptite lugs, working along the sheets to the other end.

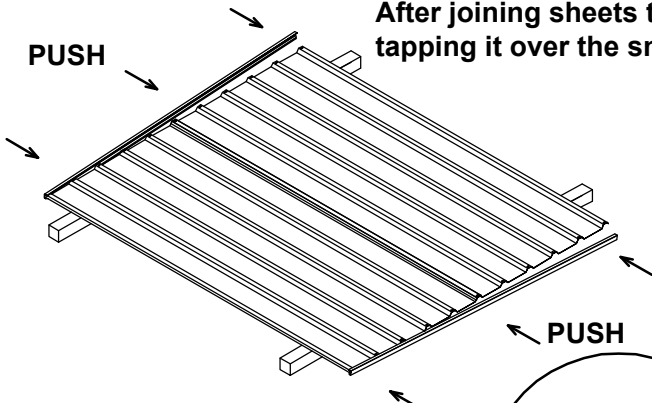

Position sheets on timbers, trestles or partly over edge of concrete slab.

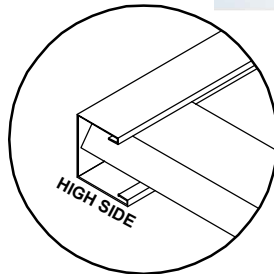

Each perimeter channel must finish flush with the edges of the sheets. The snaptite system allows adjustment for this process by simply tapping the channel along the sheets until each end is neatly flush. If you need to remove channels from the panels, pull the channel along the panel from opposing ends. You may need someone to help with this.

FASTENING SYMBOLS

 Join components together by pre-drilling the holes first. Use one component as a template to mark where the holes are. Drill with 3mm drill bit.

 Join components together with one screw at this location only, as some channel sections have extra holes that are not required for this model of garden shed

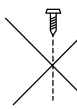
 Do not join components together at this location yet, as the screw may obstruct further assembly of other components

 3mm POP RIVETS

 4mm NUT & BOLT SET



1. REAR PANEL ASSEMBLY

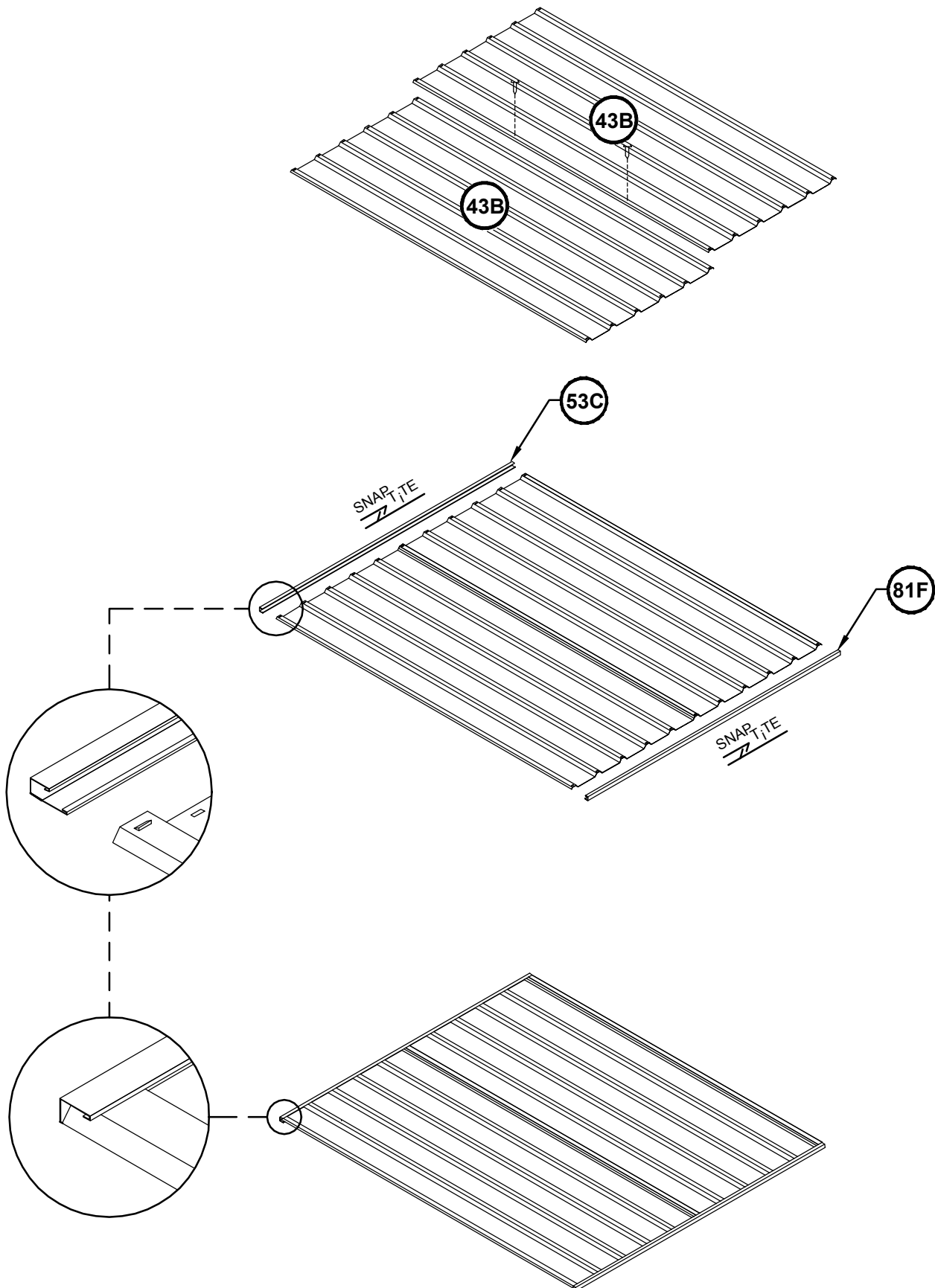



2. SIDE PANEL ASSEMBLY

(TWO REQUIRED)

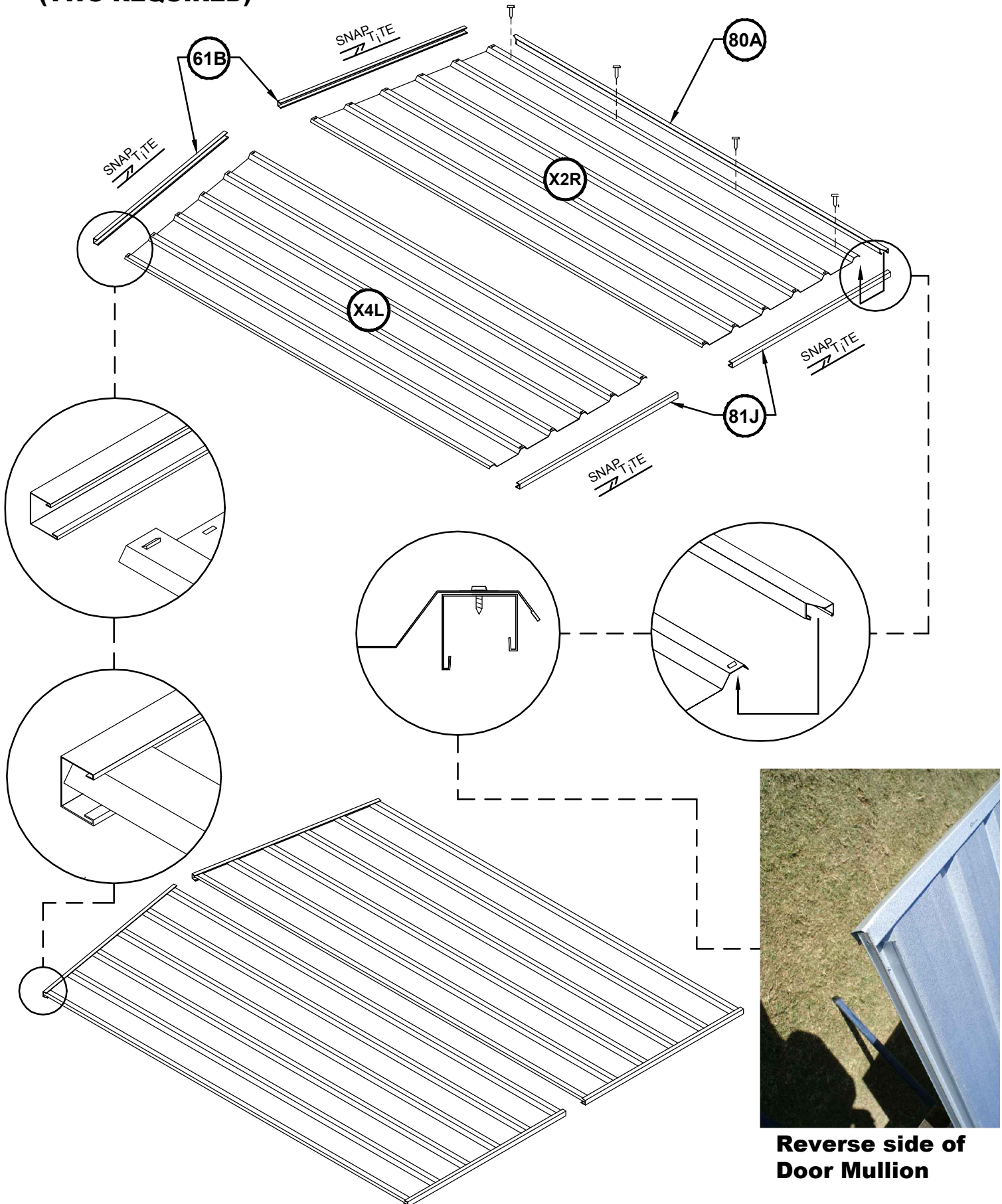



3. ROOF ASSEMBLY

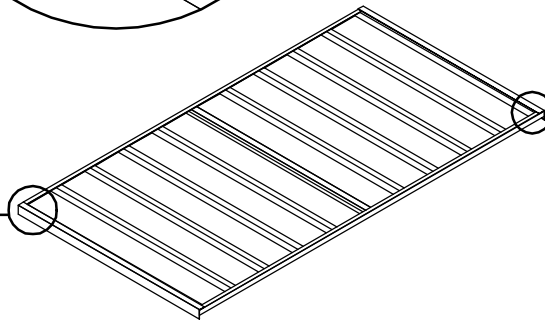
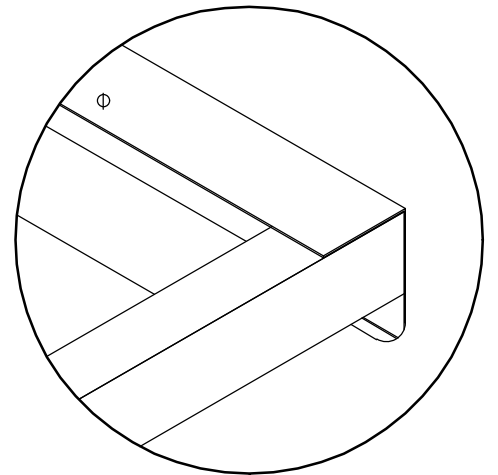
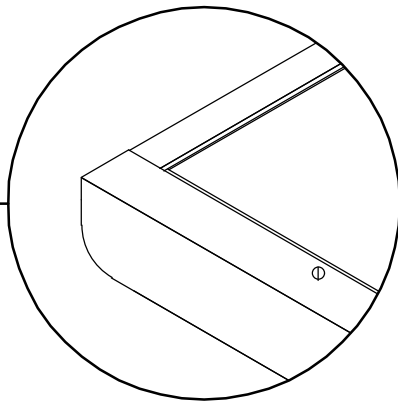
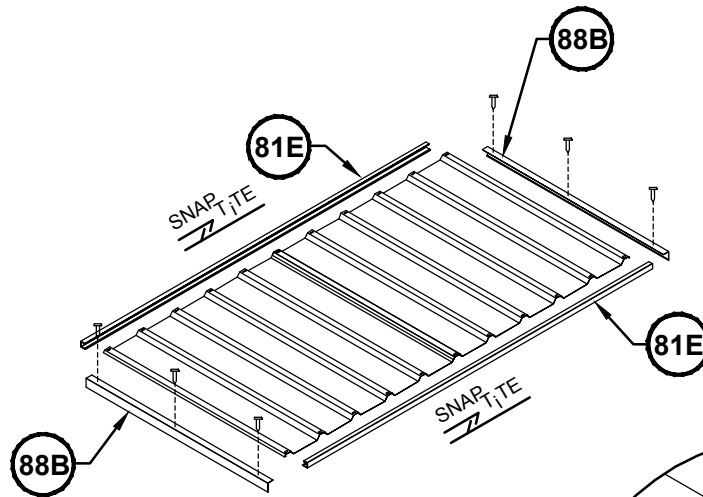
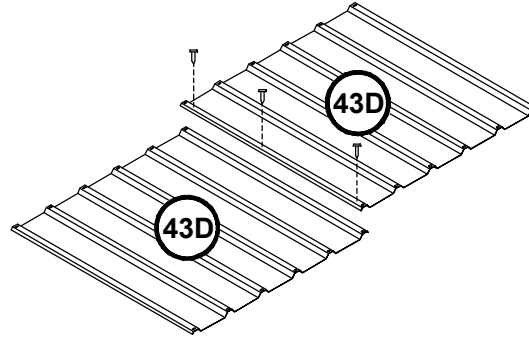



4. DOOR PANEL ASSEMBLY

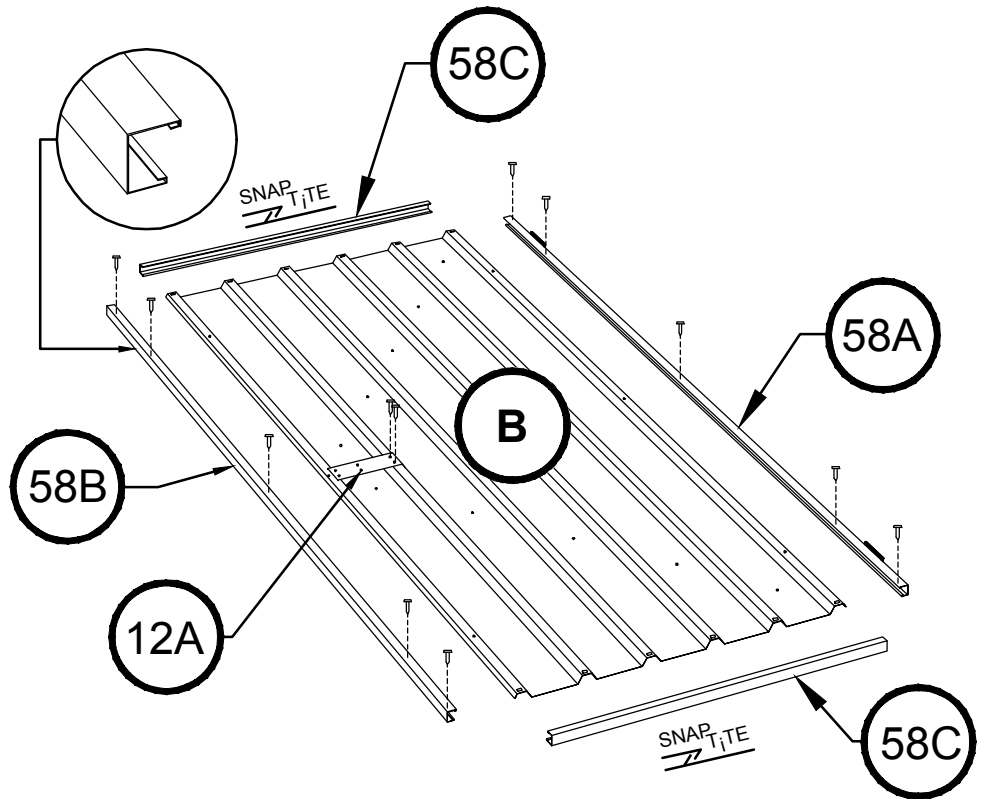

ALL VERTICAL DOOR CHANNELS ARE INSTALLED IN THE REVERSE DIRECTION IN COMPARISON TO HORIZONTAL DOOR CHANNELS

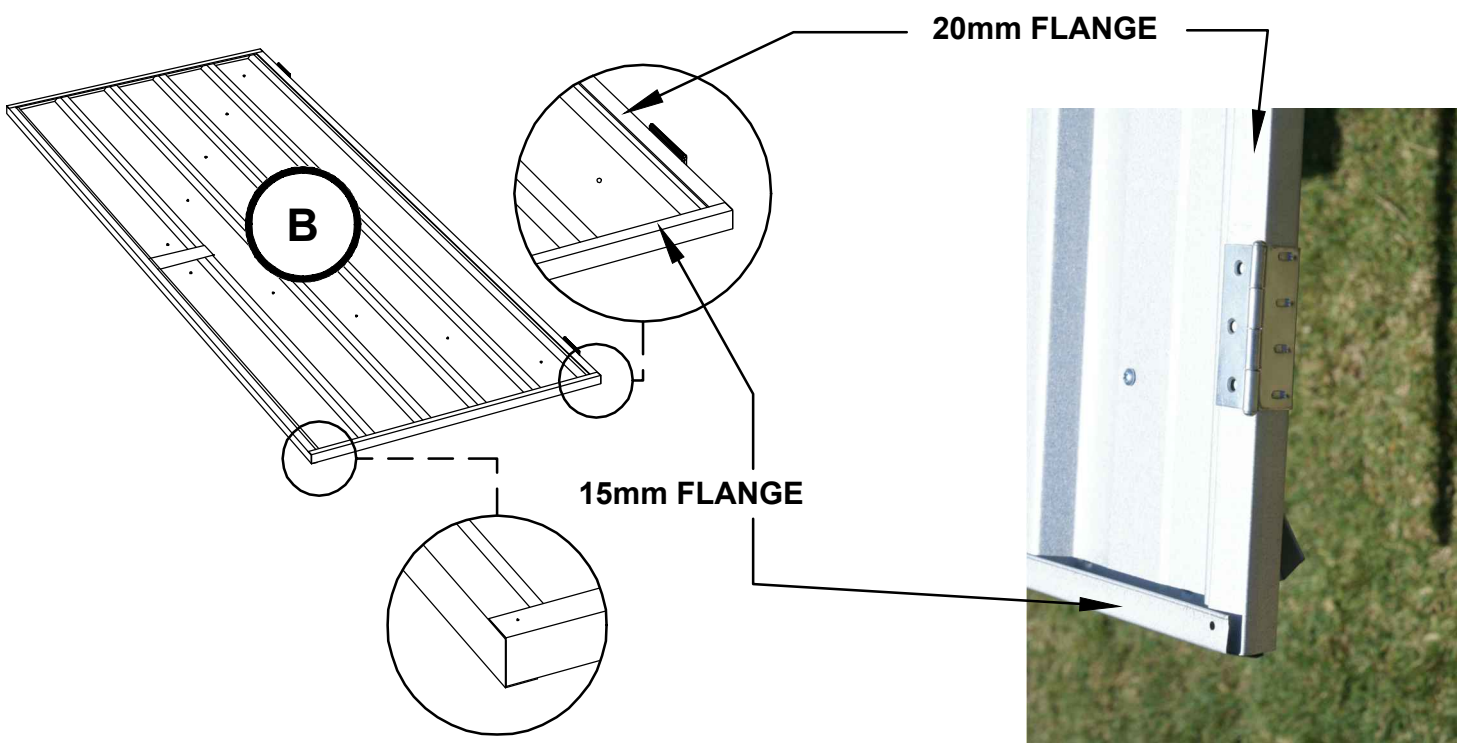



5. FRONT PANEL ASSEMBLY

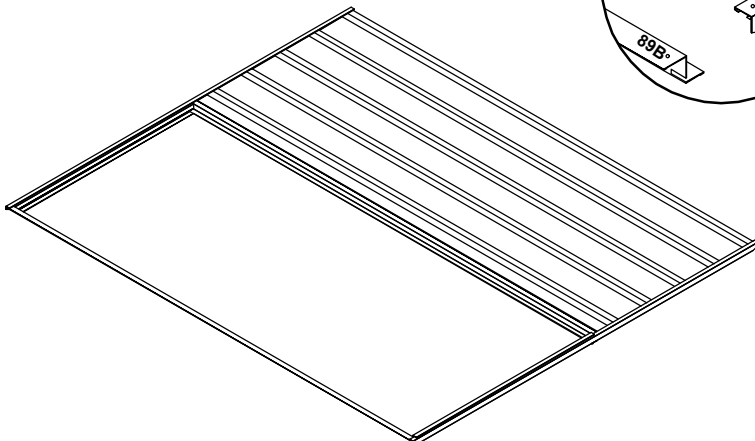
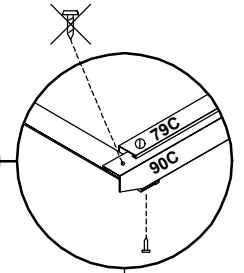
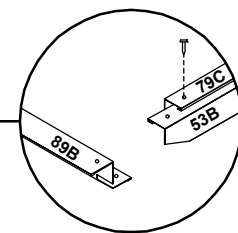
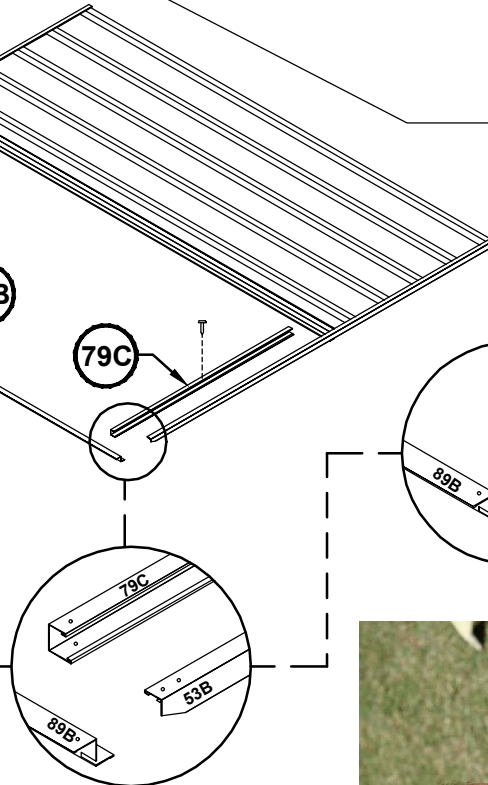
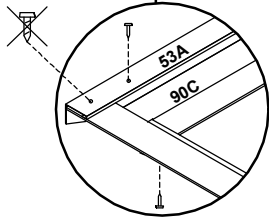
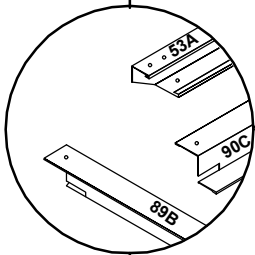
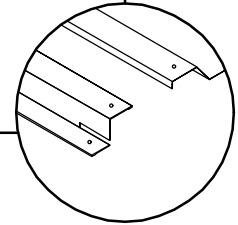
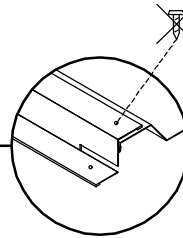
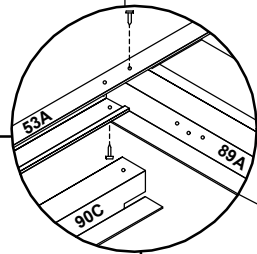
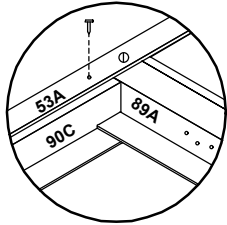
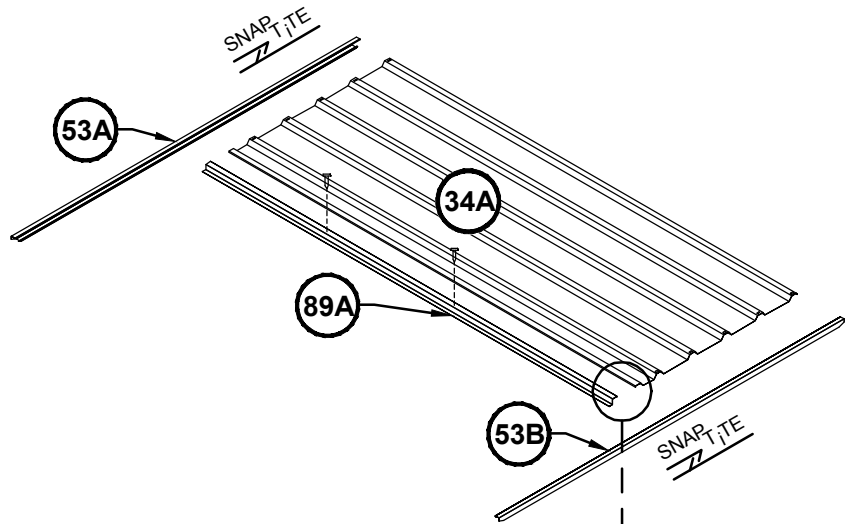



6. DOOR PANEL ASSEMBLY

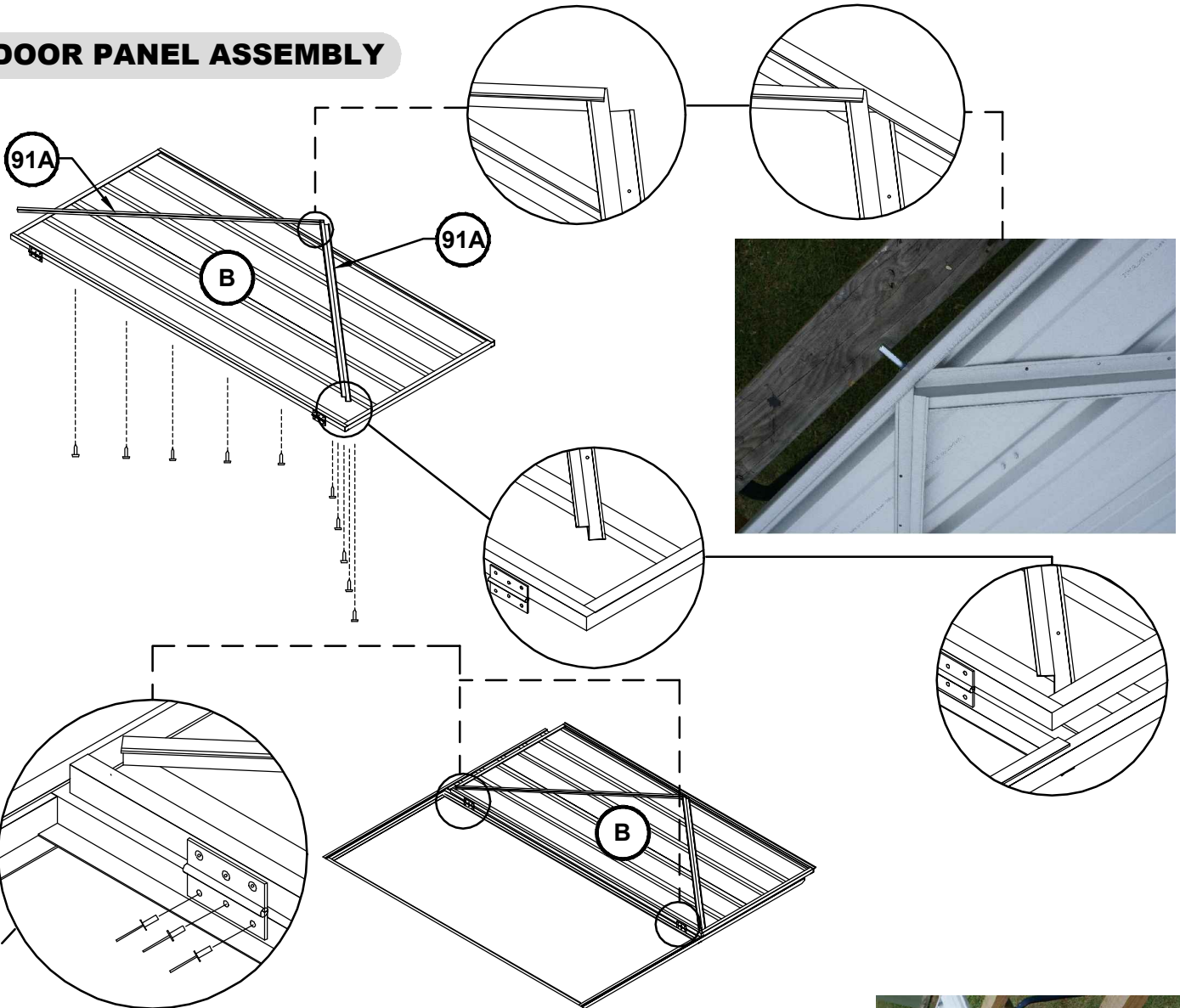

NOTE: NUTS AND BOLTS (SUPPLIED) MAY BE USED INSTEAD OF POP RIVETS (SUPPLIED) BY SIMPLY ENLARGING THE HINGE HOLE SETS IN THE JAMB USING A 4MM DRILL BIT

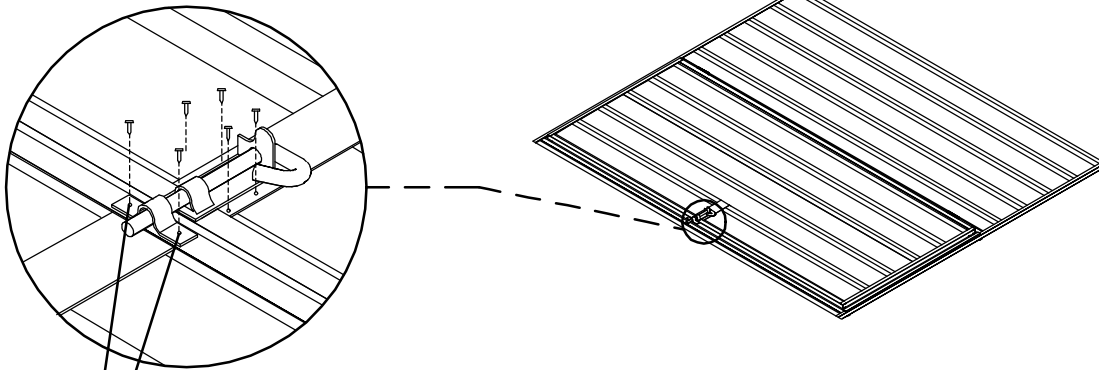

NOTE: The two holes required to connect the padbolt hasp for each door have not been pre-punched, to allow for proper alignment. position each hasp centrally over the padbolt shaft, and drill 3mm holes and secure with screws



7. PANEL CONSTRUCTION

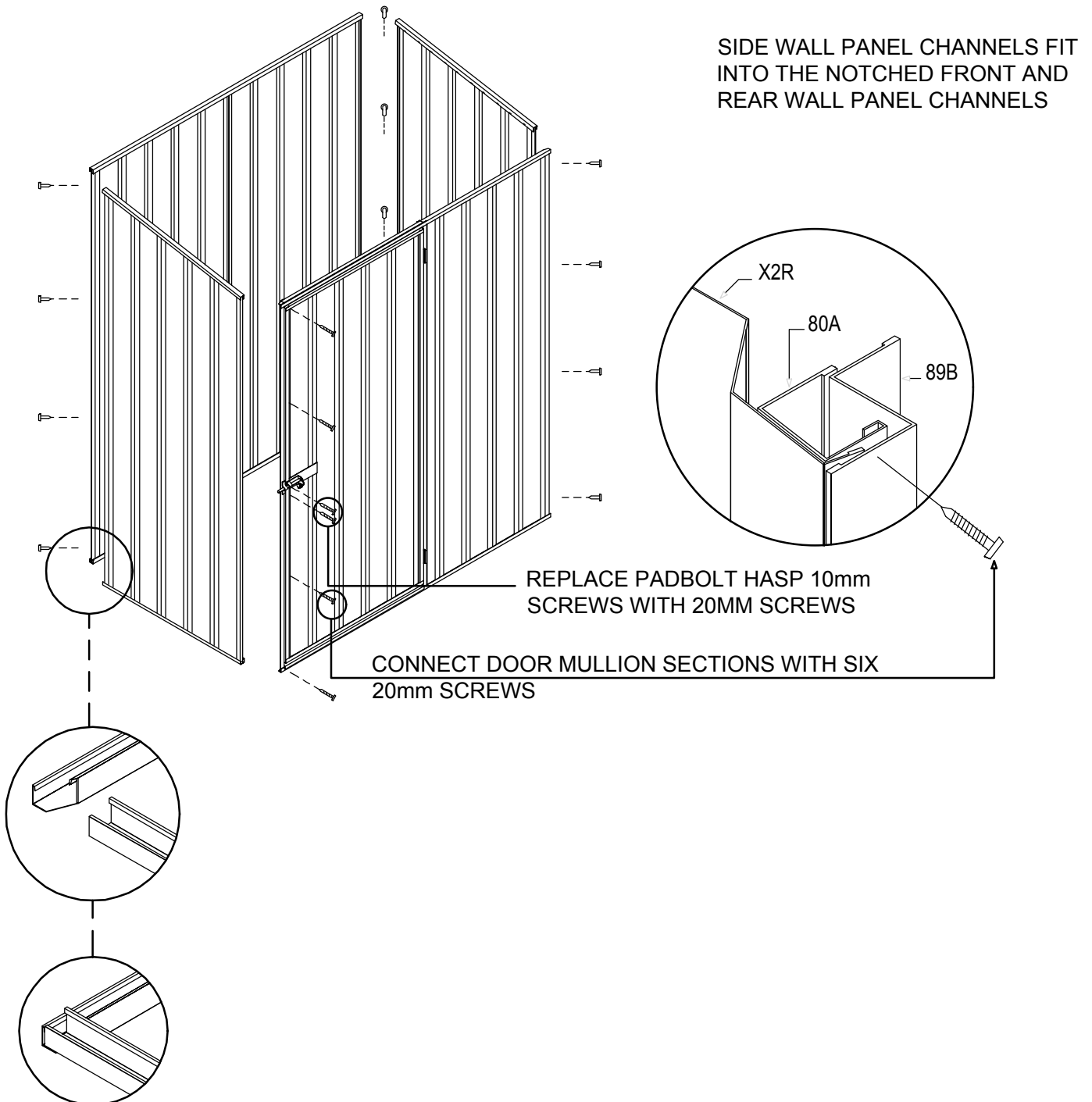



FINAL CONSTRUCTION

ANCHORING OF SHED

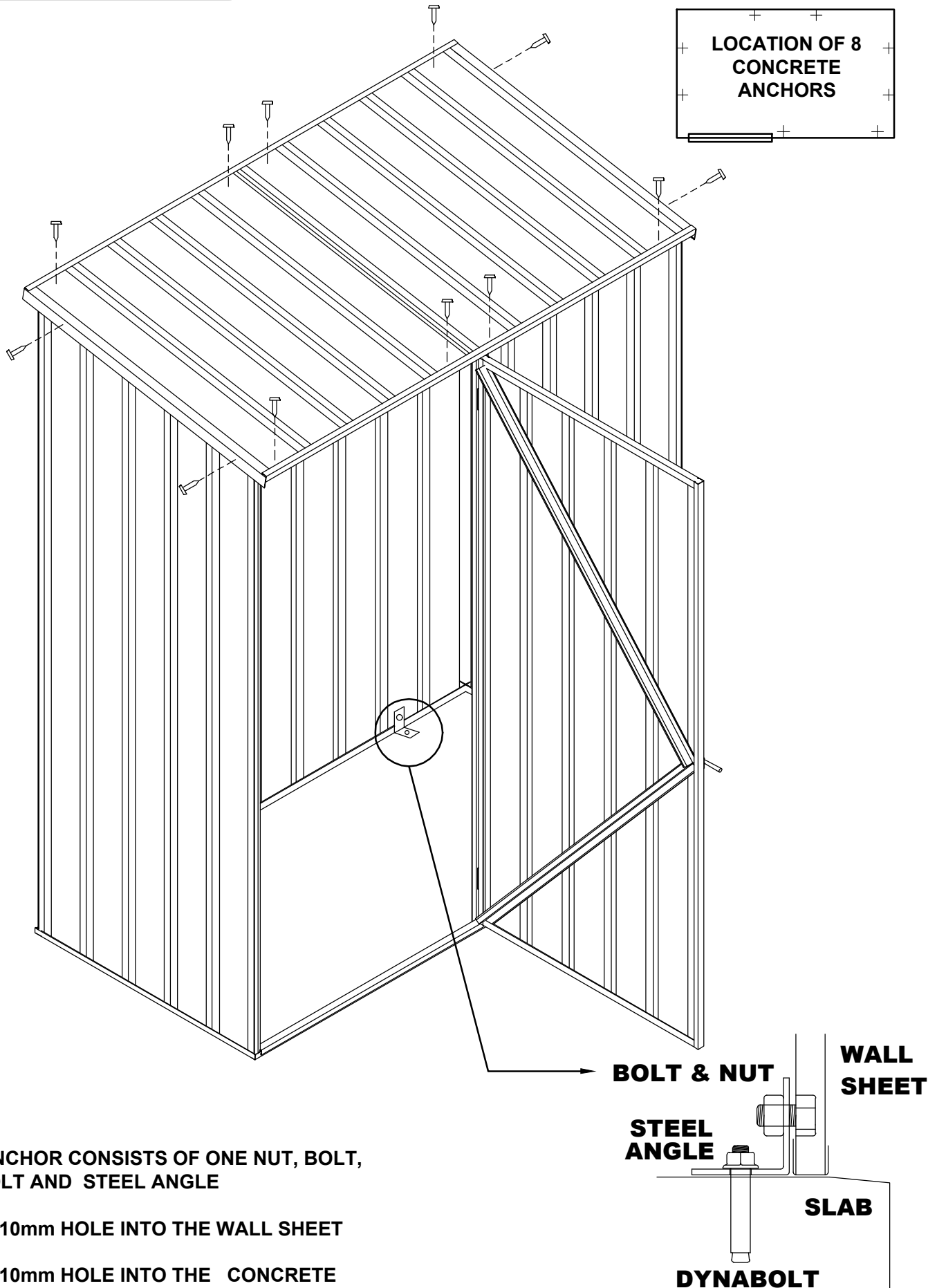



AUSTRALIA PRODUCT WARRANTY AGAINST DEFECTS

Congratulations on your purchase of an ABSCO SHED

ABSCO SHEDS, including garden sheds, garden beds, aviaries, storage units, garages, awnings and carports are made using high quality Australian made steel.

We are pleased to advise we warrant that the steel coating will not rust, crack, flake peel or blister for **30 years** from date of purchase, when installed within Australia.

This warranty does not apply to surface deterioration of panels caused by 'Swarf' (Tiny particles of steel debris left from cutting, grinding or drilling operations) that has not been removed after building construction, or as a result of contact with damp soil, chemicals, fertilisers or other corrosive substances.

This warranty covers any Absco product used for normal domestic use and installed in accordance with the installation instructions. The warranty does NOT cover Damage caused by storms, wind, rain snow or poor foundations.

This warranty does NOT cover ABSCO products installed in severe coastal, industrial or other highly corrosive environments. The warranty does not cover fasteners (screws, nuts, bolts, rivets, hasps or sliding padbolts).

The warranty is limited to replacement and delivery of components and does not include any labour or installation costs. The benefits given by the warranty are in addition to your other rights and remedies under a law in relation to the goods or services to which the warranty relates.

The warranty applies to the exclusion of all other representations, guarantees or warranties express or implied, our goods come with guarantees that cannot be excluded under the Australian consumer law and is not transferable. You are entitled to a replacement or refund for a major failure and for compensation for any other foreseeable loss or damage. You are also entitled to have the goods repaired or replaced if the goods fail to be of an acceptable quality and the failure does not amount to a major failure. For further information go to <http://www.consumerlaw.gov.au>.

Please retain a proof of purchase (sales docket or invoice) or register your warranty within 30 days of purchase here:

www.absco.com.au/register_warranty.php

In the unlikely event a warranty claim is made, it must be supported by photographic evidence and details of the defect, including component part numbers, together with proof of purchase documentation (or on-line registration of purchase) and forwarded to the address below. Upon receipt of the warranty claim, the Customer Service Manager will contact you within three business days to advise you of the assessment outcome of the claim, which may include your expenses incurred in making the claim.

THE CUSTOMER SERVICE MANAGER, ABSCO INDUSTRIES, PO BOX 119 ACACIA RIDGE QLD AUSTRALIA 4110

PHONE: 1800 029701 FAX: 07-33441191 EMAIL: warranty@absco.com.au

Issued 01 January 2013



ABSCO SHEDS - STORAGE GUIDELINES

ABSCO SHEDS include garden sheds, garden beds, storage units, aviaries, garages, awnings and carports.

ABSCO SHEDS are designed to be weatherproof for normal weather conditions. In the event of extreme weather conditions such as heavy rain, combined with high wind gusts, the ridge capping, sheeting joints, screw fixings etc., may exhibit minor deformations which may allow some water entry. These areas should be checked regularly to ensure that maximum strength and protection is maintained.

Other weather conditions such as extreme heat and extreme cold, moist or dry air can influence the effects of concrete floor moisture and/or condensation on the underside of the roof sheets.

ABSCO SHEDS and storage units are primarily used for storage of garden equipment such as lawnmowers, wheelbarrows, garden tools etc. Storage items that might be adversely affected by any of the above conditions may require additional protection such as being sealed or covered by plastic sheets and/or stacked above the concrete floor on timber slats.

Waterproof sealants may be used to offer further protection where required around joints and screw fixings, as can rubber door seals and other products which are available from most hardware outlets.

Placement of waterproof sealants (silicone) between the base of the shed and concrete slab is not recommended, as this process can have a reverse effect, preventing excess water from escaping, resulting with water accumulating and being trapped inside the shed.

Absco accepts no responsibility for water entry, floor moisture, condensation or the condition of the Contents inside your Absco steel building arising from any of the pre-mentioned weather conditions.