

**Operating Instructions**

**XBS-800**

**12 MONTHS HOME USE  
REPLACEMENT WARRANTY**

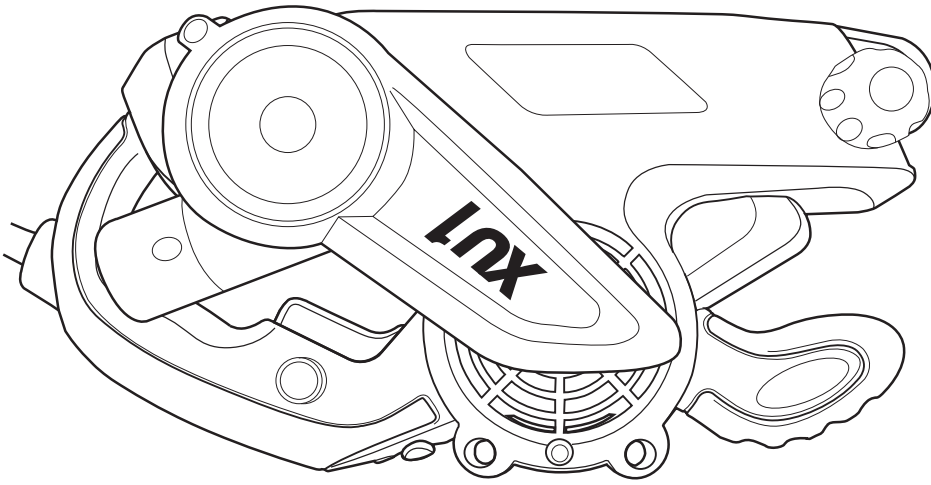

**60W  
Belt  
Sander**

**XU1**

**XU1 Power tools**

1-23 Letcon Drive, Bangholme, Victoria, Australia 3175

**Telephone:** 1800 069 486

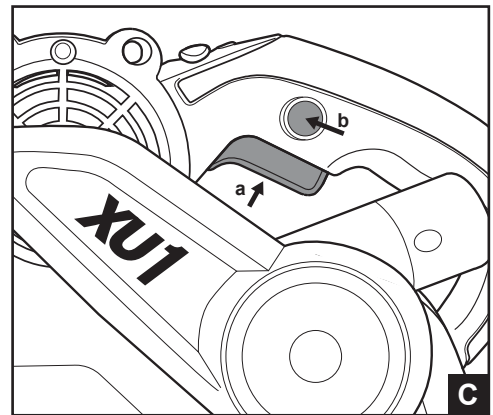
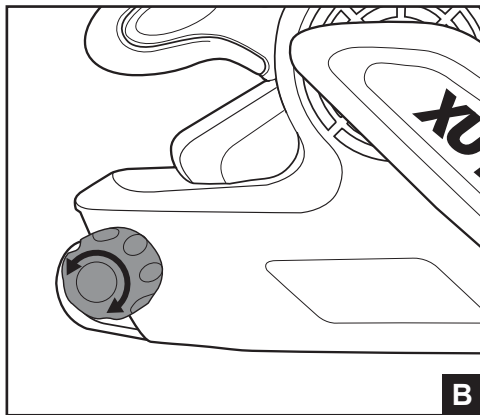
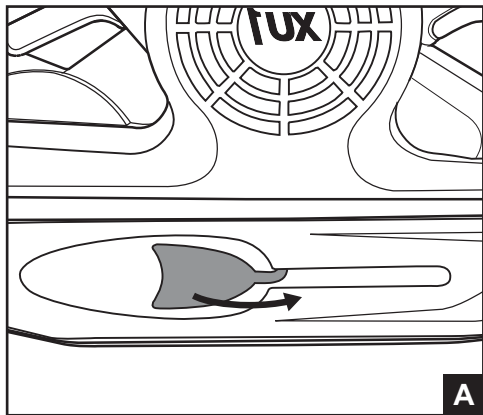
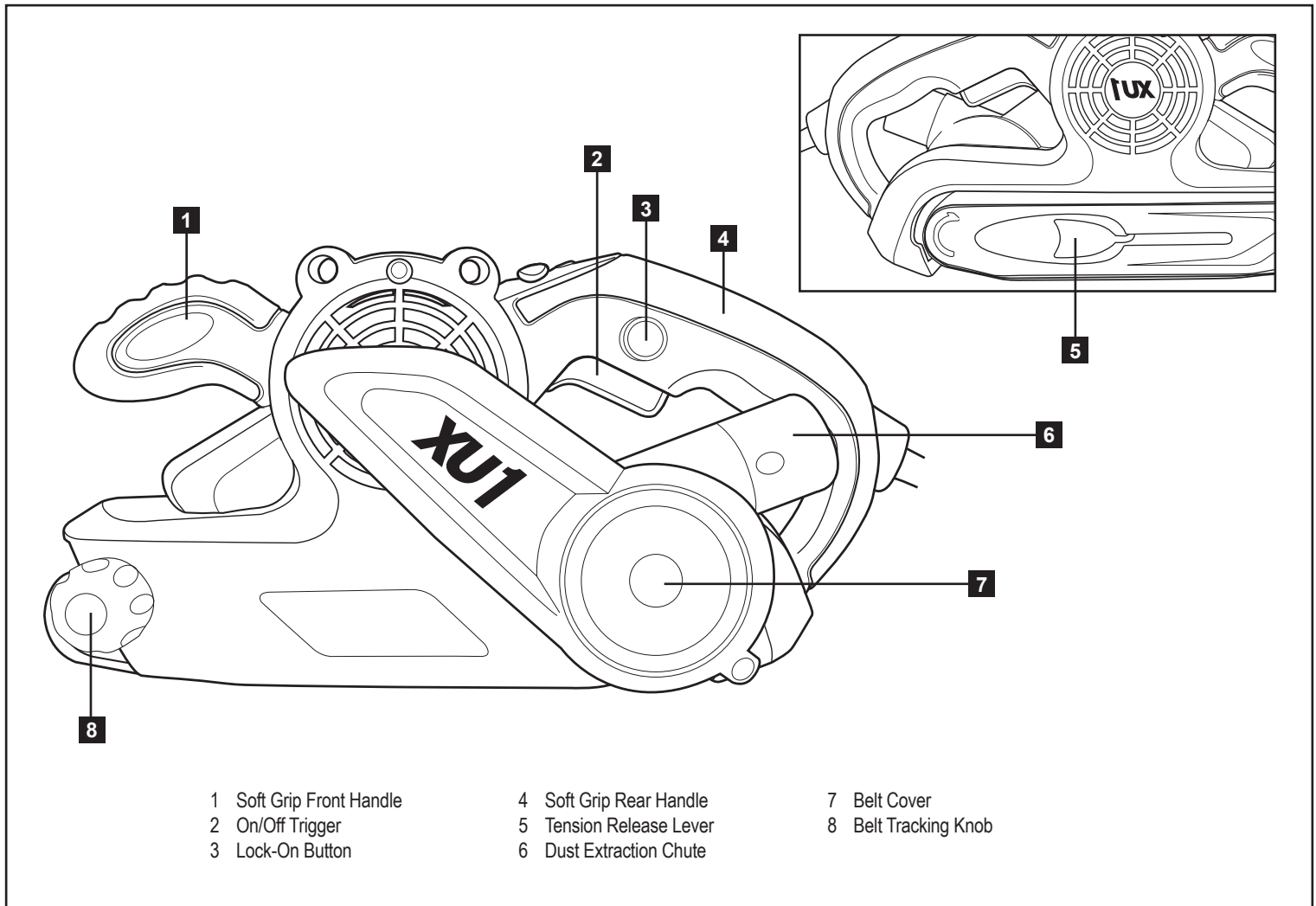

# SPECIFICATIONS

<b>Motor:</b>	900W
<b>Input Voltage:</b>	230-240V ~ 50Hz
<b>Belt Speed:</b>	380m/min
<b>Belt Size:</b>	533 x 76mm
<b>Tool Weight:</b>	3.11kg

## PROPER USE

This tool is intended for use in a DIY (Do It Yourself) context or for hobbyist purposes. It is not built for continuous daily use in a trade or professional capacity.

Before using the machine, carefully read these instructions, especially the safety rules to help ensure that your machine always operates properly.

Before attempting to operate the machine, familiarise yourself with the controls and make sure you know how to stop the machine quickly in an emergency.

Save these instructions and the other documents supplied with this machine for future reference.

## SETUP



**WARNING!** Ensure the tool is turned off, disconnected from the power supply before performing any of the following operations.

### Installing Sanding Belts

When installing a belt, ensure you have the correct size for your belt sander, and correct grit for your workpiece. Belts have arrows marked on them to assist in fitting them to the belt sander in the correct direction. Belts are also marked with a grit rating.

1. Place the belt sander on its left side on a flat surface.
2. Pull out the belt Tension Release Lever. Push it towards the front of the sander until it locks into place. The Front Roller will retract. **Fig. A**
3. Gently place the belt over the front and rear rollers. The arrows on the belt are to be aligned with the arrow marked on the belt sander.



**CAUTION!** The arrows on the belt must be aligned with the markings on the belt sander. Incorrect fitment could cause the belt to break. Belts are not covered by the warranty.

3. Once the belt is in place, return the belt Tension Release Lever to its original position.

### Removing Sanding Belts

1. Place the belt sander on its left side on a flat surface.
2. Pull out the belt Tension Release Lever. Push it towards the front of the sander until it locks into place.
3. With the belt sander still on its left side, gently slide the belt off the unit. Use two hands to ease both sides off simultaneously.

## Tracking Adjustment



**CAUTION!** Ensure body parts, cords, workpieces and any loose items are clear of the sanding belt before performing the tracking adjustment operation.

It is necessary to ensure the belt is tracking correctly, in a straight line, to avoid the belt 'tracking off' the belt sander's rollers.

1. Turn the sander upside down and hold it firmly with one hand. Press the On/Off Switch to start the sander and observe the tracking of the sanding belt.
2. If the belt tracks outward, turn the Belt Tracking Knob clockwise. If the belt tracks inward turn the Belt Tracking Knob counter clockwise. **Fig. B**
3. Adjust the belt until its outer edge is even with the outer edge of the front and rear rollers. Make sure the belt does not rub against the Rear Guide Strip. Once the belt stabilises you can begin operation.

**Note:** Always check your belt after it has been used as it may require further adjustment.

## Dust Extraction

To capture dust and debris, it is best to attach the Dust Bag.

1. To attach the Dust Bag, simply slide the dust bag Adaptor over the Dust Extraction Port on the rear of the sander housing.
2. To remove the Dust Bag, simply pull the dust bag Adaptor out of the Dust Extraction Port.

**Note:** For the dust bag to work at its optimum level, empty when it becomes 1/3 full. This allows air to flow through the bag freely, increasing its effectiveness.

## CONTROLS

### On/Off Switch

1. To turn the sander on, depress the On/Off Switch to the 'I' setting.
2. To turn the sander off, depress the On/Off Switch to the 'O' setting.

### Lock-On Button

The belt sander has been designed with a Lock-On Switch to reduce user fatigue during long periods of use.

1. Follow the instructions above to turn the sander on, then depress the Lock-On Switch. Release the On/Off Switch first then release the Lock-On Switch. **Fig. C**
2. To release the Lock-On Switch and turn off the sander, simply depress the On/Off Switch.

**Note:** It is recommended to disengage the Lock-On Switch prior to unplugging the tool from the mains power. This will ensure the Lock-On Switch is not engaged when the sander is next used and avoid accidental starting of the belt sander.

# OPERATION

## Timber Sanding



**CAUTION!** Prior to operating the sander ensure you have a firm grip on the rear handle and that the sanding belt is not in contact with the workpiece. Apply firm pressure when sanding. Excessive pressure can damage the workpiece and sander or cause the belt to 'track off'.

1. Firmly grasp the sander in front of you and away from your body.
2. To commence sanding, gently place the rear heel of the belt sander on your workpiece. Ensure that the sanding belt is not in contact with your workpiece prior to starting the sander.
3. Start the sander and let the motor build up to maximum speed. Gradually lower it onto the workpiece with a slight forward movement. This helps to prevent gouging.
4. The correct technique is a back and forth motion with most of the sanding being done on the backwards pulling movement. Do not apply a lot of pressure on the unit. Allow the sander to do the work.
5. Upon completion of the sanding operation, remove the sander from the workpiece. Turn off the sander by depressing and then releasing the On/Off Switch.

# MAINTENANCE



**WARNING!** Ensure the tool is turned off and disconnected from the power supply before performing any of the following operations.

## Cleaning



**CAUTION!** Excessive build up of dust particles may cause the sander to overheat and fail.

1. Regularly empty the dust bag.
2. Keep the ventilation slots of the sander clean at all times. If possible prevent foreign matter from entering the vents.
3. After each use, blow air through the sander housing to ensure it is free from all dust particles that may build up.
4. If the enclosure of the sander requires cleaning, use a soft, moist cloth only. Do not use solvents.



**CAUTION!** Never immerse any part of the sander in liquid.

## Carbon Brushes

Carbon brushes will wear out after many uses, causing the sander to spark and/or stop. The brushes are a wearing component of the sander and should be replaced prior to the carbon wearing out completely. Take the sander to a suitably qualified electrician or power tool repairer for replacement. Always replace both brushes at the same time.

## Replacing the Drive Belt

If the motor on your belt sander operates but the belt does not rotate, follow these instructions. In most cases it is not necessary to return the product back to the store. Check that the drive belt has not been damaged. Order a replacement belt from spare parts.

1. To remove and check the drive belt, remove the 3 screws from the belt cover. If the belt is damaged, worn or broken, replace with a new drive belt.
2. To remove the drive belt, simply use a pair of scissors to cut the drive belt.

**Note:** Do not pry the belt off the pulley as this may damage the housing.

3. To fit the new drive belt, place it around the large belt wheel. Align the ridges on the belt with the teeth on the small gear wheel. Rotate the large belt wheel and push the drive belt down onto the small gear wheel as it rotates. The wheel can be difficult to rotate until the drive belt is fed into the small gear wheel. Keep rotating the wheel and feed the drive belt onto the small gear wheel until it sits flush with the edge of the wheels.
4. Refit cover and tighten screws.

**Note:** XU1 will not be responsible for any damage or injuries caused by the repair of the tool by an unauthorised person or by mishandling of the tool.

# WARRANTY

YOUR WARRANTY FORM SHOULD BE RETAINED BY YOU AT ALL TIMES. IN ORDER TO MAKE A CLAIM UNDER THIS WARRANTY YOU MUST RETURN THE PRODUCT TO YOUR NEAREST BUNNINGS WAREHOUSE WITH YOUR BUNNINGS REGISTER RECEIPT. PRIOR TO RETURNING YOUR PRODUCT FOR WARRANTY. PLEASE TELEPHONE OUR CUSTOMER SERVICE HELPLINE:

**Australia 1800 069 486**

**New Zealand 0508 069 486**

TO ENSURE A SPEEDY RESPONSE PLEASE HAVE THE MODEL NUMBER AND DATE OF PURCHASE AVAILABLE. A CUSTOMER SERVICE REPRESENTATIVE WILL TAKE YOUR CALL AND ANSWER ANY QUESTIONS YOU MAY HAVE RELATING TO THE WARRANTY POLICY OR PROCEDURE.

The benefits provided under this warranty are in addition to other rights and remedies which are available to you at law.

Our goods come with guarantees that cannot be excluded at law. You are entitled to a replacement or refund for a major failure and for compensation for any other reasonably foreseeable loss or damage. You are also entitled to have the goods repaired or replaced if the goods fail to be of acceptable quality and the failure does not amount to a major failure.

Generally you will be responsible for all costs associated with a claim under this warranty, however, where you have suffered any additional direct loss as a result of a defective product you may be able to claim such expenses by contacting our customer service helpline above.

## 1 YEAR REPLACEMENT WARRANTY

Your product is guaranteed for a period of 12 months from the original date of purchase and is intended for DIY (Do It Yourself) use only. If a product is defective it will be replaced in accordance with the terms of this warranty. Warranty excludes consumable parts, for example: driver bits.

## WARNING

The following actions will result in the warranty being void.

- Professional, Industrial or high frequency use.
- If the tool has been operated on a supply voltage other than that specified on the tool.
- If the tool shows signs of damage or defects caused by or resulting from abuse, accidents or alterations.
- Failure to perform maintenance as set out within the instruction manual.
- If the tool is disassembled or tampered with in any way.

## XU1

Australia/New Zealand (Head Office)

1-23 Letcon Drive, Bangholme, Victoria, Australia 3175

# SAFETY INSTRUCTIONS



**WARNING!** When using mains-powered equipment, basic safety precautions, including the following, should always be followed to reduce risk of fire, electric shock, personal injury and material damage.



**ALWAYS WEAR EYE, FACE AND EAR PROTECTION**

## When operating the tool

Keep the mains cable away from any moving parts or accessories.

Never cover the ventilation slots in the tool.

## Electrical safety

The electric motor has been designed for 230-240V only. Always check that the power supply corresponds to the voltage on the rating plate.



This tool is double insulated; therefore no earth wire is required.

The power supply for this product should be protected by a residual current device (rated at 30mA or less). A residual current device reduces the risk of electric shock.

If the supply cord is damaged, it must be replaced by the manufacturer, its service agent or similarly qualified persons in order to avoid a hazard.

## Using an extension lead

Always use an approved extension lead suitable for the power input of this tool. Before use, inspect the extension lead for signs of damage, wear and ageing. Replace the extension lead if damaged or defective.

When using an extension lead on a reel, always unwind the lead completely. Use of an extension lead not suitable for the power input of the tool or which is damaged or defective may result in a risk of fire and electric shock.

It is recommended that the extension lead is a maximum of 25m in length. DO not use multiple extension leads.

## GENERAL POWER TOOL SAFETY WARNINGS



**WARNING! Read all safety warnings and all instructions.** Failure to follow the warnings and instructions may result in electric shock, fire and/or serious injury.  
**Save all warnings and instructions for future reference.** The term "power tool" in all of the warnings refers to your mains-operated (corded) power tool or battery-operated (cordless) power tool.

### 1) Work area safety

**a) Keep work area clean and well lit.** Cluttered and dark areas invite accidents.

**b) Do not operate power tools in explosive atmospheres, such as in the presence of flammable liquids, gases or dust.**

Power tools create sparks which may ignite the dust or fumes.

**c) Keep children and bystanders away while operating a power tool.** Distractions can cause you to lose control.

### 2) Electrical safety

**a) Power tool plugs must match the outlet. Never modify the plug in any way. Do not use any adapter plugs with earthed (grounded) power tools.** Unmodified plugs and matching outlets will reduce risk of electric shock.

**b) Avoid body contact with earthed or grounded surfaces such as pipes, radiators, ranges and refrigerators.** There is an increased risk of electric shock if your body is earthed or grounded.

**c) Do not expose power tools to rain or wet conditions.** Water entering a power tool will increase the risk of electric shock.

**d) Do not abuse the cord. Never use the cord for carrying, pulling or unplugging the power tool. Keep cord away from heat, oil, sharp edges or moving parts.** Damaged or entangled cords increase the risk of electric shock.

**e) When operating a power tool outdoors, use an extension cord suitable for outdoor use.** Use of a cord suitable for outdoor use reduces the risk of electric shock.

**f) If operating a power tool in a damp location is unavoidable, use a residual current device (RCD) protected supply.** Use of an RCD reduces the risk of electric shock.

### 3) Personal safety

**a) Stay alert, watch what you are doing and use common sense when operating a power tool. Do not use a power tool while drugs, alcohol or medication.** A moment of inattention while operating power tools may result in serious personal injury.

**b) Use personal protective equipment. Always wear eye protection.** Personal protective equipment such as dust mask, non-skid safety shoes, hard hat, or hearing protection used for appropriate conditions will reduce personal injuries.

**c) Prevent unintentional starting. Ensure the switch is in the off-position before connecting to power source and/or**

**battery pack, picking up or carrying the tool.** Carrying power tools with your finger on the switch or energising power tools that have the switch on invites accidents.

**d) Remove any adjusting key or wrench before turning the power tool on.** A wrench or a key left attached to a rotating part of the power tool may result in personal injury.

**e) Do not overreach. Keep proper footing and balance at all times.** This enables better control of the power tool in unexpected situations.

**f) Dress properly. Do not wear loose clothing or jewellery. Keep your hair, clothing and gloves away from moving parts.** Loose clothes, jewellery or long hair can be caught in moving parts.

**g) If devices are provided for the connection of dust extraction and collection facilities, ensure these are connected and properly used.** Use of dust collection can reduce dust-related hazards.

### 4) Power tool use and care

**a) Do not force the power tool. Use the correct power tool for your application.** The correct power tool will do the job better and safer at the rate for which it was designed.

**b) Do not use the power tool if the switch does not turn it on and off.** Any power tool that cannot be controlled with the switch is dangerous and must be repaired.

**c) Disconnect the plug from the power source and/or the battery pack from the power tool before making any adjustments, changing accessories, or storing power tools.** Such preventive safety measures reduce the risk of starting the power tool accidentally.

**d) Store idle power tools out of the reach of children and do not allow persons unfamiliar with the power tool or these instructions to operate the power tool.** Power tools are dangerous in the hands of untrained users.

**e) Maintain power tools. Check for misalignment or binding of moving parts, breakage of parts and any other condition that may affect the power tools operation. If damaged, have the power tool repaired before use.** Many accidents are caused by poorly maintained power tools.

**f) Keep cutting tools sharp and clean.** Properly maintained cutting tools with sharp cutting edges are less likely to bind and are easier to control.

**g) Use the power tool, accessories and tool bits etc. in accordance with these instructions and in the manner intended for the particular type of power tool, taking into account the working conditions and the work to be performed.** Use of the power tool for operations different from those intended could result in a hazardous situation.

**h) Keep handles and grasping surfaces dry, clean and free from oil and grease.** Slippery handles and grasping surfaces do not allow for safe handling and control of the tool in unexpected situations.

### 5) Service

**a) Have your power tool serviced by a qualified repair person using only identical replacement parts.** This will ensure that the safety of the power tool is maintained.

## ADDITIONAL SAFETY WARNINGS FOR BELT SANDERS

 **WARNING! Hold power tool by insulated gripping surfaces, because the sanding pad may contact its own cord.** Cutting a 'live' wire may make exposed metal parts of the power tool 'live' and could give the operator an electric shock.

**Recommendations for the use of a residual current device** with a rated residual current of 30mA or less.

### Safety Warnings Specific for Belt Sanding Operations:

- Do not wet sand with this sander.** Liquids entering the motor housing are an electrical shock hazard.
- Keep fingers and clothing away from the belt.** They could get cut or wedged between the pulley, belt and motor housing.
- Properly adjust tracking of belt to avoid it overhanging the housing.** A running belt overhanging its housing can cause severe lacerations.
- Keep the cord to the side away from pulleys.** The cord can be dragged into the belt housing and become entangled with the pulleys.

### Safety Warnings Common for Sanding Operations:

- Always wear eye protection and a dust mask for dusty applications and when sanding overhead.** Sanding particles can be absorbed by your eyes and inhaled easily and may cause health complications.
- Use special precautions when sanding chemically pressure treated timber, paint that may be lead based, or any other materials that may contain carcinogens.** A suitable breathing respirator and protective clothing must be worn by all persons entering the work area. Work should be sealed by plastic sheeting and persons not protected should be kept out until work area is thoroughly cleaned.
- Unplug the sander before changing accessories.** Accidental start-ups may occur if the sander is plugged in while changing an accessory.
- Disposing of dust.** Be extremely careful of dust disposal, materials in fine particle form may be explosive. Do not throw sanding dust on an open fire. Spontaneous combustion, may in time, result from a mixture of oil or water with dust particles.

**WARNING!** Some dust created by power sanding, sawing, grinding, drilling and other construction activities contain chemicals known to cause cancer, birth defects or other reproductive harm.

Some examples of these chemicals are:

- Lead from lead-based paints;
- Crystalline silica from bricks, cement and other masonry products, and;
- Arsenic and chromium from chemically-treated timber.

The risk from such exposures vary depending on how often you do this type of work. To reduce your exposure to these chemicals; work in a well ventilated area, and work with approved safety equipment,

such as those dust masks that are specifically designed to filter out microscopic particles.

**This appliance is not intended for use by persons (including children) with reduced physical, sensory or mental capabilities, or lack of experience and knowledge,** unless they have been given supervision or instruction concerning use of the appliance by a person responsible for their safety.

**Young children should be supervised** to ensure that they do not play with the appliance.

## DESCRIPTION OF SYMBOLS



Read instruction manual



Wear eye, breathing and hearing protection



R.C.M. Regulatory compliance mark



Do not put in the rubbish



Double insulated

V

Volts

~

Alternating current

Hz

Hertz

W

Watts



Warning

## CARING FOR THE ENVIRONMENT



Power tools that are no longer usable should not be disposed of with household waste but in an environmentally friendly way.

Please recycle where facilities exist. Check with your local council authority for recycling advice.



Recycling packaging reduces the need for landfill and raw materials.

Reuse of recycled material decreases pollution in the environment. Please recycle packaging where facilities exist.

Check with your local council authority for recycling advice.