

ASSEMBLY INSTRUCTION

# MANDALA BENCH 160CM

TOP

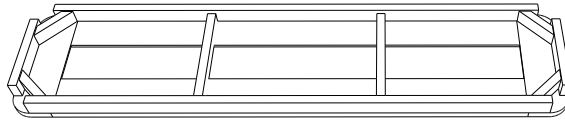

LEG

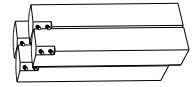

STEP 1

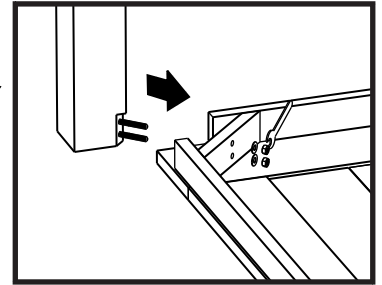
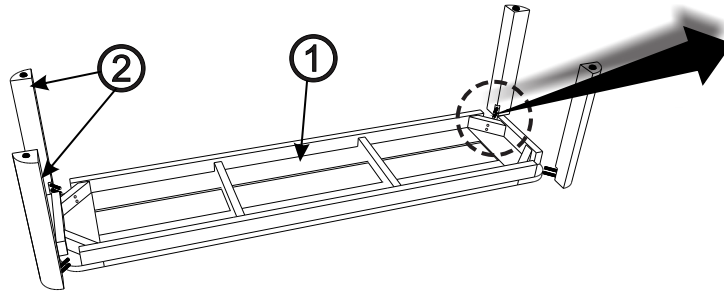

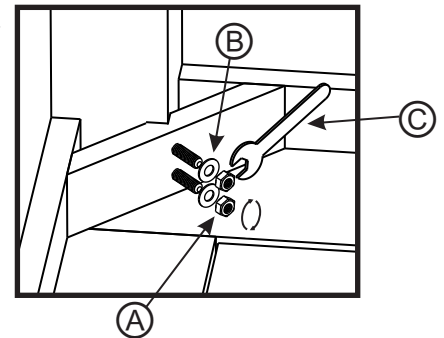
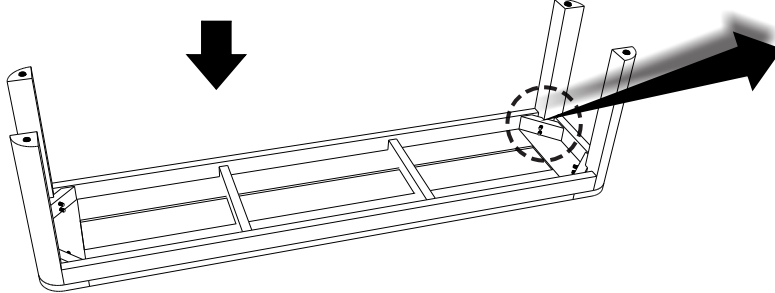

STEP 2



ASSEMBLY PARTS

- ① Top = 1 pc
- ② Leg = 4 pcs

ASSEMBLY TOOLS

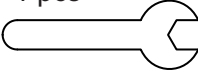
- Ⓐ 8 pcs 
- Ⓑ 8 pcs 
- Ⓒ 1 pcs 

**WARRANTY CONDITIONS**

Any claim under this warranty must be made within 3 years of the date of purchase of the product. To make a claim under the warranty, take the product (with proof of purchase) to any Bunnings store (see [www.bunnings.com.au](http://www.bunnings.com.au) or [bunnings.co.nz](http://bunnings.co.nz) for store locations)

Bunnings Group Ltd bears reasonable, direct, expenses of claiming under the warranty. You may submit details and proof to our store for consideration. The warranty covers manufacturer defects in materials, workmanship and finish under normal use.

This warranty is provided in addition to other rights and remedies you may have under law: our goods come with guarantees which cannot be excluded under the Australian Consumer Law or Consumer Guarantees Act 1993 (NZ). You are entitled to replacement or refund for a major failure and to compensation for other reasonably foreseeable loss or damage. You are also entitled to have the goods repaired or replaced if the goods fail to be of acceptable quality and the failure does not amount to a major failure.

The warranty excludes damage resulting from product misuse or product neglect. The warranty covers domestic use only and does not apply to commercial applications.

This warranty is given by Bunnings Group Limited ABN 26 008 672 179, 16-18 Cato Street, Hawthorn East, Victoria 3123, e-mail: [customer\\_support@bunnings.com.au](mailto:customer_support@bunnings.com.au). Or call our Customer Support Team – Ph.1800 797 586

This warranty is given by Bunnings NZ Limited: Postal address: PO Box 14436, Panmure, Auckland 1741, e-mail: [marketing@bunnings.co.nz](mailto:marketing@bunnings.co.nz) Or call our Customer Support Team – Ph.1800 797 586

**WARRANTY EXCLUSIONS**

Fading due to weather exposure or damage to the frame and timber slats through accident, misuse or negligence. Timber leeching/staining tiles due to leaving furniture outdoors when not in use.

