



**scy**on  
TECHNOLOGY

# Timber Cavity Batten Technical Specification

# Contents

<b>1</b>	<b>APPLICATION AND SCOPE</b>	<b>3</b>	<b>5</b>	<b>STRIA CLADDING INSTALLATION</b>	<b>6</b>
1.1	Application	3	5.1	General	6
1.2	Scope	3	5.2	Fastener durability	7
1.3	Details	3	5.3	Fastener – size and layout	7
1.4	Specific design	3	<b>6</b>	<b>JOINTS</b>	<b>8</b>
<b>2</b>	<b>DESIGN</b>	<b>3</b>	6.1	Vertical joint	7
2.1	Compliance	3	6.2	Horizontal joint	7
2.2	Responsibility	3	6.3	Drainage joint	7
2.3	Site and foundation	3	6.4	Internal corner joint	7
2.4	Clearances	3	6.5	External corner joint	7
2.5	Moisture management	4	<b>7</b>	<b>FINISHES</b>	<b>7</b>
2.6	Structure	4	7.1	Painting	7
2.7	Fire rated walls	4	7.2	Flexible sealant	8
2.8	Structural bracing	4	<b>8</b>	<b>STORAGE AND HANDLING</b>	<b>8</b>
2.9	Energy efficiency	4	<b>9</b>	<b>MAINTENANCE</b>	<b>8</b>
<b>3</b>	<b>FRAMING</b>	<b>5</b>	<b>10</b>	<b>PRODUCT INFORMATION</b>	<b>8</b>
3.1	General	5	10.1	Manufacturing and classification	8
3.2	Timber framing	5	10.2	Product mass	8
3.3	Steel framing	5	10.3	Durability	8
3.4	Special framing requirements	5	<b>11</b>	<b>SAFE WORKING PRACTICES</b>	<b>9</b>
3.5	Tolerances	5	<b>12</b>	<b>PRODUCT AND ACCESSORIES</b>	<b>10</b>
<b>4</b>	<b>PREPARATION</b>	<b>5</b>	<b>13</b>	<b>DETAILS</b>	<b>12</b>
4.1	Building underlay / HomeRAB Pre-Cladding	5		<b>PRODUCT WARRANTY</b>	<b>35</b>
4.2	Rab board	6			
4.3	Cavity closure / vent strip	6			
4.4	Cavity battens	6			
4.5	Intermediate support	6			
4.6	Flashings	6			
4.7	Junctions and penetrations	6			

## WE VALUE YOUR FEEDBACK

To continue with the development of our products and systems, we value your input. Please send any suggestions, including your name, contact details, and relevant sketches to:

**Ask James Hardie™**

Fax 0800 808 988

[literaturefeedback@jameshardie.co.nz](mailto:literaturefeedback@jameshardie.co.nz)



# 1 Application and scope

## 1.1 APPLICATION

---

Stria® Cladding installed as per this specification gives a panelised plastered masonry appearance on building facades. Stria Cladding can be fixed to either timber or lightweight steel-framed external walls. A wide range of colours can be used varying from light to dark. Stria Cladding is available in 405mm wide x 4200mm lengths and is 14mm thick.

### If you are a specifier

Or other responsible party for a project ensure that the information in this document is appropriate for the application you are planning and that you undertake specific design and detailing for areas which fall outside the scope of these specifications.

### If you are an installer

Ensure that you follow the design, moisture management principles, associated figures and material selection provided by the designer and this James Hardie Technical Specification. All the details provided in this document must be read in conjunction with the project specification.

### Make sure your information is up to date

When specifying or installing James Hardie products, ensure that you have the current manual. Additional installation information, warranties and warnings are available at [www.jameshardie.co.nz](http://www.jameshardie.co.nz) or Ask James Hardie™ on 0800 808 868.

## 1.2 SCOPE

---

This specification covers the installation of Stria Cladding fixed over timber cavity battens on buildings that fall within the scope limitation of NZS 3604 and E2/AS1 of the New Zealand Building Code (NZBC).

This specification also covers the installation of Stria Cladding on projects, which are subject to specific engineering design (SED) up to a wind pressure of 2.5kPa (ULS).

Note: Refer to Stria Cladding CLD Structural Cavity Batten technical specification when fixing to CLD Structural Cavity Battens.

## 1.3 DETAILS

---

Various typical Stria Cladding construction details are provided in the Details section of this document. These details are available in CAD, ArchiCAD, MOD and pdf file format and can be downloaded from our website at [www.jameshardie.co.nz](http://www.jameshardie.co.nz).

All dimensions shown are in millimetres unless noted otherwise.

## 1.4 SPECIFIC DESIGN

---

For use of the Stria Cladding on specific design projects, the designer, architect or engineer must ensure that all clauses of NZBC have been considered and a specific design has been undertaken for the areas which fall outside the scope of this literature.

# 2 Design

## 2.1 COMPLIANCE

---

Stria Cladding installed in accordance with this specification has been tested as per E2/VM1 and complies with External Moisture - E2 Clause of NZBC. The cladding has also been tested and complies with the requirements of Structure - B1, Durability - B2, Energy Efficiency - H1 and Hazardous Building Material - F2 Clauses of NZBC.

## 2.2 RESPONSIBILITY

---

The specifier or other party responsible for the project must ensure that the information and details in this specification are appropriate for the intended application and that additional detailing is performed for specific design or any areas that fall outside the scope of this technical specification. For applications outside the scope of this literature and details, which are not provided herein, the architect, designer or engineer must undertake specific design and it should be ensured that the intent of their design meets the requirements of the NZBC.

All New Zealand Standards referenced in this manual are current editions and must be complied with.

James Hardie conducts stringent quality checks to ensure that any product manufactured falls within our quality spectrum. It is the responsibility of the builder to ensure that the product meets aesthetic requirements before installation. James Hardie will not be responsible for rectifying obvious aesthetic surface variations following installation.

## 2.3 SITE AND FOUNDATION

---

The site on which the building is situated must comply with E1/AS1 Surface Water Clause of NZBC.

Foundations design must comply with relevant regulations, standards and meet the requirements of NZBC.

The grade of adjacent finished ground must slope away from the building to avoid any possibility of water accumulation.

## 2.4 CLEARANCES

---

The clearance between the bottom edge and paved/unpaved ground of cladding must comply with section 9.1.3 of E2/AS1. The finished floor must also comply with these requirements. These clearances must be maintained throughout the life of the building.

Stria Cladding must overhang the bottom plate by a minimum of 50mm as required by E2/AS1.

Stria Cladding must maintain a minimum clearance of 100mm from paved ground, and 175mm from unpaved ground. On the roofs and decks, the minimum clearance must be 50mm.

Do not install external cladding such that it may remain in contact with water or ground. Refer Figures 4 and 5.

## 2.5 MOISTURE MANAGEMENT

It is the responsibility of the specifier to identify moisture related risks associated with any particular building design.

Wall construction design must effectively manage moisture, considering both interior and exterior environments of the building, particularly in buildings that have a higher risk of wind driven rain penetration. The buildings should also be ventilated sufficiently to control moisture accumulation due to condensation especially in artificially cooled/heated buildings.

Walls shall include those provisions as required by External Moisture Clause E2/AS1 of NZBC. In addition, all wall openings, penetrations, junctions, connections, window sills, heads and jambs must incorporate appropriate flashings for waterproofing. The other materials, components and installation methods used to manage moisture in external walls, must comply with the requirements of relevant standards and the NZBC. For further guidance on designing for weather tightness, refer to BRANZ Ltd. and the Department of Building and Housing updates on the following websites respectively, [www.branz.co.nz](http://www.branz.co.nz) and [www.dbh.govt.nz](http://www.dbh.govt.nz).

In addition, the following issues must also be considered:

- Sealant must be installed where detailed in this literature.
- Where the walls are higher than two storeys, it is necessary to provide a horizontal flashing at the second floor level to drain the cavity.
- The installation of smoke chimneys, pipe penetrations and other fixtures etc. must not track moisture into the wall or restrict the drainage of moisture to the exterior.

## 2.6 STRUCTURE

### 2.6.1 Timber Framing

Timber-framed buildings must either be in accordance with NZS 3604 (Timber Framed Buildings) or designed as per specific engineering design. For a building requiring a specific engineering design, the framing stiffness must be equivalent to or more than the stiffness requirements of NZS 3604.

For specific design projects, the timber framing must be designed in accordance with the requirements of NZS 3603 and AS/NZS 1170.

For timber frame walls longer than 12m, it is best practice to allow for construction joints to accommodate movements generated due to timber shrinkage or deflections etc.

### 2.6.2 Steel Framing

Steel-framed buildings must comply with the requirements of AS/NZS 3404 'Steel Structures Standard' or specific engineering design requirements. Also refer to NASH 3405 steel framed buildings guidance document published by 'National Association of Steel Housing' (NASH).

### 2.6.3 Wind Pressures

Stria Cladding is suitable for use in all wind zones in New Zealand up to and including EH as defined in NZS 3604.

Stria Cladding is also suitable in specific design projects up to wind pressures of 2.5kPa uls.

## 2.7 FIRE RATED WALLS

Stria Cladding when fixed over timber cavity battens to external walls can achieve fire ratings up to 60/60/60 to comply with Clause C/AS1 of the NZBC when the walls are constructed in accordance with the current James Hardie 'Fire and Acoustic' Design Manual.

Stria Cladding is classified as a 'non-combustible' material suitable for use on walls close to a boundary.

## 2.8 STRUCTURAL BRACING

Stria Cladding installed as per this specification has not been tested and therefore cannot be used to achieve any structural bracing. However, bracing can be achieved by using James Hardie rigid air barrier installed direct to framing instead of a building underlay or by using Villaboard® Lining bracing system on the internal face.

## 2.9 ENERGY EFFICIENCY

External walls constructed using Stria Cladding and bulk insulation, where the area of glazing is 30% or less of the total wall area, constructed as per this technical specification complies with the insulation requirements for walls in NZBC Acceptable Solution H1/AS1 (Energy Efficiency Clause H1), Replacement Table 1. To meet thermal insulation requirements for the construction, the bulk insulation as specified in Table 1 must be used. This insulation may be substituted with insulations having higher R-values. The thermal insulation of a wall changes when the size or spacing of timber framing is increased or decreased. The calculation used in Table 1 is based on a timber framing size 90 x 45mm and using an internal lining material such as James Hardie Villaboard Lining or a 10mm plasterboard.

Table 1

Insulation capability		
Climate Zone*	R-Value Requirement*	Cavity Insulation Infill Requirement
1 and 2	1.9 m <sup>2</sup> °C/W	#R2.0
3	2.0 m <sup>2</sup> °C/W	#R2.2
<p>Total construction R-Value depends on the insulation material used and the framing ratio. The insulation material R-Values specified in this table are for studs spaced at 600mm c/c and nogs spaced at 800mm c/c.</p> <p># To achieve higher R-Values of construction the wall insulation material must be replaced with an insulation material having higher R-Values to suit the requirements.</p> <p>For further guidance on insulation requirement refer to the current edition of 'House Insulation Guide' published by BRANZ.</p>		

# 3 Framing

## 3.1 GENERAL

---

Stria Cladding can be fixed either to a timber-frame or steel-frame.

For fixing into steel frame Ask James Hardie on 0800 808 868 for specific requirements.

- Studs must be provided at 600mm centres maximum.
- Nogs must be provided at 800mm centres maximum.

Note: For fixing Stria Cladding, fastener spacing is provided in Section 5.

## 3.2 TIMBER FRAMING

---

### 3.2.1 Dimensions

A 45 x 90mm minimum framing size is required.

A minimum 70mm wide stud is required at vertical joint flashing joints.

### 3.2.2 Structural Grade

Timber grade used must be in accordance with timber grades specified in NZS 3604.

### 3.2.3 Durability

The external framing timber must be treated to a minimum H1.2 treatment. Higher treatment levels may be used but check for the compatibility of treatment chemicals with other materials. Refer to NZBC Acceptable Solution B2/AS1 Durability for further information about the durability requirements.

For timber treatment and allowable moisture content information refer to NZS 3602 (Timber and Wood-Based Products for use in Buildings) and NZS 3640 (Chemical Preservation of Round Sawn Timber) for minimum timber treatment selection and treatment requirements.

Also refer to framing manufacturer's literature for further guidance on timber selection. Framing must be protected from moisture at sites in accordance with the framing manufacturer recommendations.

*Note: Refer to NZS 3602 for information about the allowable moisture content in timber framing.*

### 3.2.4 Frame Construction

Use of timber framing must be in accordance with NZS 3604 and the framing manufacturer's specifications. The framing must be rigid and not rely on the cladding for stability. Timber framing sizes and its set-out must comply with NZS 3604 and as specified in this technical specification.

The following framing is required:

- Studs must be provided at 600mm centres maximum.
- Nogs must be provided at 800mm centres maximum.
- When studs are spaced at 400mm centres then the nogs / dwangs may be provided at 1200mm centres
- An extra stud is required in internal corners
- For specific design projects exposed to wind speeds higher than 50m/sec, the stud spacing must be closed to 400mm c/c.

## 3.3 STEEL FRAMING

---

### 3.3.1 Dimensions and Gauge

A 38mm minimum wide stud can be used to install Stria Cladding. The thickness of steel frame must be in the range 0.55 to 1.6mm BMT (Base Metal Thickness). Considering the ease of installation, the recommended minimum BMT is 0.75mm.

### 3.3.2 Durability

The steel framing must have the appropriate level of coating to comply with durability requirements of NZBC.

### 3.3.3 Frame Construction

Steel framing must comply with NASH handbook/guidelines. Stud and batten spacing must not be more than what has been specified in this specification. Refer to framing manufacturer's specifications or NASH 3405 for further guidance on steel frame.

## 3.4 SPECIAL FRAMING REQUIREMENTS

---

The following are special framing requirements for both timber and steel framing:

- Double studs are required at internal corners, refer Figure 15.
- Extra packers maybe required at external corners.

## 3.5 TOLERANCES

---

In order to achieve the required performance and an acceptable wall finish, it is imperative that framing is straight and true. Framing tolerances shall comply with Table 2.1 of NZS 3604 and the manufacturer's specifications. All framing shall be made flush.

# 4 Preparation

## 4.1 BUILDING UNDERLAY / HOMERAB PRE-CLADDING

---

Building underlay / HomeRAB® Pre-Cladding must be provided as per the requirements of External Moisture Clause E2 of NZBC. The building underlay selected for use must comply with Table 23 of E2/AS1.

The building underlay must be fixed in accordance with section 9.1.7 E2/AS1 and underlay manufacturer's recommendations.

Walls which are not lined on the inside face e.g. garage walls or gable ends must include a rigid sheathing or an air barrier behind the cladding which complies with Table 23 of E2/AS1. James Hardie HomeRAB Pre-Cladding complies with these requirements and is suitable for use in this situation. It must be installed in accordance with James Hardie Rigid Air Barriers installation manual.



## 4.2 RAB BOARD

---

General building underlay or HomeRAB Pre-Cladding is suitable for use up to very high wind speed zone (50m/sec).

When an EH windzone or for specific design projects where the wind pressure is higher than 1.5kPa, James Hardie RAB Board must be used instead of building underlay.

To achieve the temporary weathertightness using James Hardie rigid air barriers, windows/doors need to be temporarily installed. Refer to James Hardie Rigid Air Barriers installation manual for information regarding its installation.

## 4.3 CAVITY CLOSURE / VENT STRIP

---

The James Hardie Stria Aluminium Cavity Closure or uPVC cavity vent strip must be installed at the bottom of all walls and above all openings constructed using the drained and ventilated cavity construction method. It is important that the openings in the cavity closure/vent strip are kept clear and unobstructed to allow free drainage and ventilation of cavities. James Hardie cavity closure / vent strip has an opening area of 1000mm<sup>2</sup>/m length.

## 4.4 CAVITY BATTENS

---

Stria Cladding to be installed on a cavity. The battens provide ventilation and drainage between the frame and the panel and are considered a "packer" only in this specification.

The timber cavity battens must be minimum H3.1 treated in accordance with NZS 3640 (Chemical preservation of rough and sawn timber) to comply with the durability requirements of B2/AS1.

Cavity battens must comply with E2/AS1 and:

- be minimum 18mm thick
- be as wide as the width of studs
- fixed vertically to studs
- be fixed by the cladding fixings to the main framing over the building underlay. Therefore until claddings are fixed the battens only need to be tacked to framing by 40 x 2.8mm or longer nails at 800mm c/c.

## 4.5 INTERMEDIATE SUPPORT

---

Where studs are at 600mm centres an intermediate means of restraining the building underlay and insulation from bulging into the cavity shall be installed. An acceptable method to achieve this is using one of the following options:

- intermediate cavity batten between the studs
- 75mm galvanised mesh
- polypropylene tape at 300mm centres fixed horizontally and drawn taut

No intermediate supports are required:

- when studs are spaced at 400mm centres
- when rigid air barriers instead of building underlays are used.

## 4.6 FLASHINGS

---

All wall openings, penetrations, intersections, connections, window sills, heads and jambs must be flashed prior to Stria Cladding installation. Refer to moisture management requirements in Clause 2.5. The building underlay/rigid air barrier must be appropriately incorporated with penetration and junction flashings using flashing tapes. Materials must be lapped in such a way that water tracks down to the exterior on the face of building underlay or rigid air barrier. James Hardie will assume no responsibility for water infiltration within the wall due to poor installation of flashings or building underlay.

The selected flashing materials must comply with the durability requirements of NZBC. For information refer to Table 20 of E2/AS1.

When using James Hardie rigid air barriers the entire framing around openings must be sealed with a flashing tape. The tape must be finished over the face of the rigid air barrier. Refer to James Hardie Rigid Air Barriers installation manual for further information.

## 4.7 JUNCTIONS AND PENETRATIONS

---

Refer to Clause 2.5 of this specification for moisture management requirements. All windows and doors must be detailed as per the requirements of this specification. James Hardie has developed the window details for Stria Cladding which meet the requirements of E2 External Moisture, an approved document of the NZBC. Refer to Figures 17 to 19.

# 5 Stria Cladding installation

## 5.1 GENERAL

---

Stria Cladding must be kept under cover whilst in storage or at sites and they must be dry at the time of their installation. All site cut panel edges must be sealed with Dulux Acraprime 501/1, Dulux Primacryl, Resene Quick Dry or similar sealer compatible with the finish coat before installation.

Stria Cladding must be fully supported and fixed into timber cavity battens. Ensure that cladding is hard against the battens to avoid drumminess.

To achieve best aesthetic results it is recommended to position vertical jointer by the corner of openings or coinciding with the centre line of openings. Refer to Figure 3

This technical specification only covers the horizontal installation of Stria Cladding.

Ask James Hardie on 0800 808 868 for vertical installation technical supplement of Stria Cladding.

# 6 Joints

## 5.2 FASTENER DURABILITY

Fasteners must meet the minimum durability requirements of the NZBC. NZS 3604 specifies the requirements for fixing material to be used in relation to exposure conditions and are summarised in Table 2.

Table 2

Exposure conditions and nail selection prescribed by NZS 3604		
NAIL MATERIAL		
Zone D	Zone C outside sea spray zone and Zone B and geothermal hot spots	Bracing - all zones
Grade 316 Stainless	Hot-dipped galvanised or 316 Stainless	Grade 316 Stainless

\*(Zone C areas where local knowledge dictates that increased durability is required, appropriate selection shall be made). Microclimate conditions as detailed in NZS 3604, Paragraph 4.2.4 require SED.

Also refer to the NZBC Acceptable Solution E2/AS1' Table 20 and 21 for information regarding the selection of suitable fixing materials and their compatibility with other materials.

## 5.3 FASTENER – SIZE AND LAYOUT

Stria Cladding must be fixed to framing using the fixings as specified in Table 3 below and follow the edge distance required for nails as shown in the details. Refer to Figure 7.

When using rigid air barrier like HomeRAB Pre-Cladding or RAB Board, the cladding fixing nails must be increased in length equal to the thickness of the rigid air barrier.

Table 3

Panel fixing	
cavity construction	
65x2.87mm D head or 60x2.87mm RounDrive nails	Fix nails at 100mm from top edge and 100mm from bottom edge/per board/per stud. Refer to Figure 12

For other fixing options Ask James Hardie on 0800 808 868.

- When fixing the panels using nail guns, refer to the nail gun manufacturer for information about nails and the type of nail gun to be used.
- Stud width of 70mm min required when using a vertical joint flashing. Refer Figure 9.
- D head nails - finish nails 2mm below panel surface.
- RounDrive nails - finish nails flush with panel surface.

## 6.1 VERTICAL JOINT

Stria Cladding can be jointed using vertical joint flashing, trimline joint flashing or a butt joint. Refer to Figures 7 to 11.

A single stud is required when using trimline joint flashing. Refer to Figure 7. Double studs are required when using vertical joint flashing. Refer Figure 9.

## 6.2 HORIZONTAL JOINT

Stria Cladding panels are lapped over each other as per Figure 12. There is a minimum 25mm lap between the two panels. Ensure that Stria Cladding panels are securely interlocked before nailing. Stria Cladding can run continuous over floor joists without any horizontal joint when LVL timber floor joists are used. Refer to Figure 28.

When an engineered joist or LVL joist is not used, a horizontal joint or a movement joint must be formed at floor joist, refer to Figures 25 and 26.

## 6.3 DRAINAGE JOINT

After every two floors a horizontal drainage joint flashing is required, refer to Figure 26.

## 6.4 EXTERNAL CORNER JOINT

An external box corner flashing is used to fix the external corners, refer to Figure 13 and 14.

## 6.5 INTERNAL CORNER JOINT

An internal corner flashing is to be used to form an internal corner joint, refer to Figure 15. Alternatively an internal mitre corner, refer to Figure 16.

An extra stud is required in internal corners.

*Note: All joint mouldings to be fixed at 400mm centres both sides.*

# 7 Finishes

## 7.1 PREPARATION

The D head nail heads must be finished 2mm below the panel surface. The nail holes must be filled with an exterior grade two part builders fill, ie. CRC Builders Fill or similar two part external grade filler. The RounDrive nail heads must finish flush with panel surface.

## 7.2 PAINTING

Stria Cladding is pre-primed and is suitable for site applied acrylic paints.

In order to seal cut edges or sanded patches, Dulux Primacryl, Acroprime 501/1 Resene Quick Dry or a similar product should be applied. The primer should be compatible with the paint to be used.

Painting of Stria Cladding is mandatory to meet the durability requirements of NZBC and 15 year James Hardie product warranty. Stria Cladding must be dry and free of any dust or grime before painting. The panels must be painted within 90 days of their installation. There is no restriction on the LRV of paint to be applied on the Stria Cladding.

# 10 Product information

James Hardie recommends a minimum of two coats of exterior grade acrylic paint. Follow the paint manufacturer's recommendations to prepare the surface and to adequately cover and conceal the panel fixings.

## 7.3 FLEXIBLE SEALANT

Sealant used must comply with the relevant requirements of the NZBC. Their application and usage must be in accordance with the manufacturer's instructions. Check with the sealant manufacturer prior to coating over sealant. Some sealant manufacturers do not recommend coating over their product.

## 8 Storage and handling

Stria Cladding must be laid flat on a smooth level surface. Edges and corners must be protected from chipping.

To ensure optimum performance, store panels under cover and keep dry prior to fixing. If the panels become wet, allow them to dry thoroughly before fixing.

Do not carry panels on the flat, carry in the vertical position to avoid excessive bending.

## 9 Maintenance

It is the responsibility of the specifier to determine normal maintenance requirements to maintain the effectiveness of the cladding. The extent and nature of maintenance required will depend on the geographical location and exposure of the building.

As a guide, it is recommended that the basic normal maintenance tasks shall include, but not be limited to:

- Washing down exterior surfaces every 6-12 months\*
- Re-coating exterior protective finishes\*\*
- Regular inspection and repair if necessary of the cladding, sealants, etc.
- Cleaning out gutters, down pipes and overflow pipes as required.
- Pruning back vegetation which is close to or touching the building as well as ensuring the NZBC ground clearance requirements are maintained especially where gardens are concerned.
- The clearance between the bottom edge of the Stria Cladding and the finished/unfinished ground must always be maintained.

*\*Do not use a water blaster to wash down the cladding.*

*\*In extreme coastal conditions or sea spray zones, wash every 3-4 months.*

*\*\*Refer to your paint manufacturer for washing down and recoating requirements related to paint performance.*

## 10.1 MANUFACTURING AND CLASSIFICATION

Stria Cladding is an advanced lightweight cement composite cladding manufactured using James Hardie formulation. Basic composition is Portland cement, ground sand, cellulose fibre and water.

Stria Cladding is manufactured to Australian / New Zealand Standard AS/NZS 2908.2 'Cellulose-Cement Products' (ISO 8336 'Fibre-Cement Flat Sheet' ).

Stria Cladding is classified Type A, Category 2 in accordance with AS/NZS 2908.2 "Cellulose-Cement Products".

For Safety Data Sheets (SDS) visit [www.jameshardie.co.nz](http://www.jameshardie.co.nz) or Ask James Hardie on 0800 808 868.

## 10.2 PRODUCT MASS

Stria Cladding is manufactured in 14.0mm thickness and has a mass of 13.8kg/m<sup>2</sup> at EMC.

Stria Cladding is defined as a Light Weight Wall Cladding (not exceeding 30kg/m<sup>2</sup>) as per NZS 3604.

## 10.3 DURABILITY

Stria Cladding and James Hardie rigid air barrier installed and maintained as per this technical specification will meet the durability requirement for cladding as per Durability B2 clause of NZBC.

### 10.3.1 Resistance to Moisture/Rotting

Stria Cladding has tested to check its resistance to permanent moisture induced deterioration (rotting) by passing the following tests in accordance with AS/NZS 2908.2:

- Water Permeability (Clause 8.2.2)
- Warm Water (Clause 8.2.4)
- Heat Rain (Clause 6.5)
- Soak Dry (Clause 8.2.5)

### 10.3.2 Resistance to fire

Stria Cladding is classified as 'Non-Combustible Material' which is suitable for use as external wall cladding and complies with Performance C3.7 of the NZBC Clause C3 Fire Affecting Areas Beyond the Fire Source.

### 11.3.3 Alpine Regions

In regions subject to freeze/thaw conditions, Stria Cladding and James Hardie rigid air barrier must not be in direct contact with snow or ice build up for extended periods, e.g. external walls in alpine regions must be protected where snowdrifts over winter is expected.

These products have been tested in accordance with AS/NZS 2908.2 Clause 8.2.3.



# 11 Safe working practices

## DO NOT BREATHE DUST AND CUT ONLY IN WELL VENTILATED AREA

James Hardie products contain respirable crystalline silica which is considered by some international authorities to be a cause of cancer from some occupational sources. Breathing excessive amounts of respirable silica dust can also cause a disabling and potentially fatal lung disease called silicosis, and has been linked with other diseases. Some studies suggest smoking may increase these risks. During installation or handling: (1) work in outdoor areas with ample ventilation; (2) minimise dust when cutting by using either 'Score and Snap' knife, fibre cement shears or, where not feasible, use a HardieBlade™ Saw Blade and dust-reducing circular saw attached to a HEPA vacuum; (3) warn others in the immediate area to avoid breathing dust; (4) wear a properly-fitted, approved dust mask or respirator (e.g. P1 or P2) in accordance with applicable government regulations and manufacturer instructions to further limit respirable silica exposures. During clean-up, use HEPA vacuums or wet cleanup methods - never dry sweep. For further information, refer to our installation instructions and Safety Data Sheets available at [www.jameshardie.co.nz](http://www.jameshardie.co.nz).

### FAILURE TO ADHERE TO OUR WARNINGS, SAFETY DATA SHEETS, AND INSTALLATION INSTRUCTIONS MAY LEAD TO SERIOUS PERSONAL INJURY OR DEATH.

James Hardie recommended safe working practices
<p><b>CUTTING OUTDOORS</b></p> <ol style="list-style-type: none"> <li>1. Position cutting station so wind will blow dust away from the user or others in working area.</li> <li>2. Use one of the following methods based on the required cutting rate:</li> </ol> <p><b>BEST</b></p> <ul style="list-style-type: none"> <li>• Dust reducing circular saw equipped with HardieBlade™ Saw Blade and HEPA vacuum extraction.</li> </ul> <p><b>GOOD</b></p> <ul style="list-style-type: none"> <li>• Dust reducing circular saw with HardieBlade™ Saw Blade.</li> </ul>
<p><b>SANDING/REBATING/DRILLING/OTHER MACHINING</b></p> <p>When sanding, rebating, drilling or machining you should always wear a P1 or P2 dust mask and warn others in the immediate area.</p>
<p><b>IMPORTANT NOTES</b></p> <ol style="list-style-type: none"> <li>1. For maximum protection (lowest respirable dust production), James Hardie recommends always using "Best" — level cutting methods where feasible.</li> <li>2. NEVER use a power saw indoors.</li> <li>3. NEVER use a circular saw blade that does not carry the HardieBlade™ logo.</li> <li>4. NEVER dry sweep — Use wet suppression or HEPA vacuum.</li> <li>5. NEVER use grinders.</li> <li>6. ALWAYS follow tool manufacturers' safety recommendations.</li> </ol> <p>P1 or P2 respirators should be used in conjunction with above cutting practices to further reduce dust exposures. Additional exposure information is available at <a href="http://www.jameshardie.co.nz">www.jameshardie.co.nz</a> to help you determine the most appropriate cutting method for your job requirements. If concern still exists about exposure levels or you do not comply with the above practices, you should always consult a qualified industrial hygienist or contact James Hardie for further information.</p>

### Working Instructions

- Refer to Recommended Safe Working Practices before starting any cutting or machining of product.

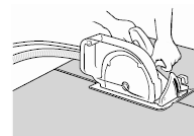

### HardieBlade™ Saw Blade

The HardieBlade™ Saw Blade used with a dust-reducing saw is ideal for fast, clean cutting of James Hardie fibre cement products. A dust-reducing saw uses a dust deflector or a dust collector connected to a vacuum system. When sawing, clamp a straight-edge to the sheet as a guide and run the saw base plate along the straight edge when making the cut.

### Hole-Forming

#### For smooth clean cut circular holes:

- Mark the centre of the hole on the sheet.
- Pre-drill a 'pilot' hole.
- Using the pilot hole as a guide, cut the hole to the appropriate diameter with a hole saw fitted to a heavy duty electric drill.

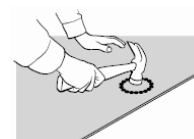

#### For irregular holes:

- Small rectangular or circular holes can be cut by drilling a series of small holes around the perimeter of the hole then tapping out the waste piece from the sheet face.
- Tap carefully to avoid damage to sheets, ensuring that the sheet edges are properly supported.

### Handling and Storage

All materials should be stored to avoid damage, with edges and corners of the Stria Cladding protected from chipping.

Stria Cladding must be protected from rain during transport and storage. Stria Cladding must be laid flat undercover on a smooth level surface clear of the ground to avoid exposure to water or moisture etc. Stria Cladding and James Hardie rigid air barrier is resistant to permanent water damage when installed as directed, and must only be installed in a dry state.

When handling Stria Cladding, carry panels on the edge taking care not to chip edges and corners.

Refer to the current installation manual for recommended Safe Working Practices.







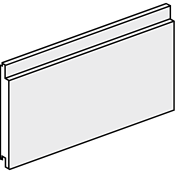
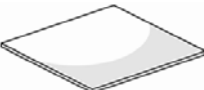
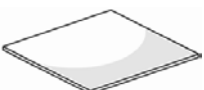

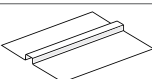

### Quality

James Hardie conducts stringent quality checks to ensure that any product manufactured falls within our quality spectrum. It is the responsibility of the builder to ensure that the product meets aesthetic requirements before installation. James Hardie will not be responsible for rectifying obvious aesthetic surface variations following installation.

# 12 Product and accessories





Stria Cladding information					
Product	Description	Size (mm)			Code
		Thickness	Length	Width	
	<b>Stria Cladding</b> A 14mm profiled panel for expressed jointed residential facades. Factory sealed on all six sides. Each panel has a manila white colour primer applied on its face, which accepts a wide range of paint finishes.	14	4200	405	404263
	<b>James Hardie rigid air barrier</b> Used as a rigid air barrier. It has green colour sealer applied over one face. Installed with green side facing out.	6	2450	1200	402980
		6	3000	1200	402981
	<b>HomeRAB Pre-Cladding</b> Used as a rigid air barrier. It has green colour sealer applied over one face. Installed with green side facing out.	4.5	2450	1200	404766
		4.5	2750	1200	404768

Note: All dimensions and masses provided are approximate only and subject to manufacturing tolerances.

Accessories/tools supplied by James Hardie			
Accessories	Description	Size/Quantity	Code
	<b>Vertical Joint Flashing</b> Aluminium extrusion used behind cladding at vertical joints.	3000mm long	305507
	<b>Stria Trimline Joint Flashing</b> Aluminium extrusion used behind cladding at vertical joints.	3000mm long	305827
	<b>Internal Corner Flashing</b> Anodised aluminium extrusion used to create internal corners.	3000mm long	304871
	<b>Stria External Box Corner</b> Anodised aluminium extrusion used to create external corners.	2700mm long	305824
		4000mm long	305823
	<b>Aluminium Window Jamb Flashing</b> Aluminium moulding used beside window opening to end butt the Stria Cladding.	3000mm long	305430
	<b>Stria Aluminium Cavity Closure</b> Aluminium moulding used as vermin proofing.	3000mm long	305431
	<b>JH 9mm Panel Aluminium External Box Corner</b> A box corner mould to form the external joints. 9mm etch primed.	2450mm long	304509
		2750mm long	304510
		3000mm long	305150
		4000mm long	305808
	<b>uPVC Vent Strip</b> PVC moulding used as vermin proofing.	3000mm long	302490
<b>Tools</b>			
	<b>HardieBlade™ Saw Blade</b> Diamond tip 184mm diameter fibre cement circular saw blade. Spacers not included.	Each	300660
	<b>HardieFlex™ Stainless Steel 316 Nails</b> For fixing panels through cavity battens. 60 x 3.15mm	Jar	302782
	<b>HardieFlex™ Hot Dip Galv. Nails</b> For fixing panels through cavity battens. 60 x 3.15mm	Jar	302784

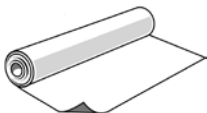
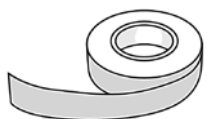
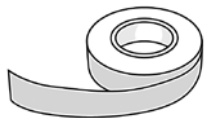
## Accessories/tools not supplied by James Hardie

James Hardie recommends the following products for use in conjunction with Stria Cladding and James Hardie rigid air barrier. James Hardie does not supply these products and does not provide a warranty for their use. Please contact component manufacturer for information on their warranties and further information on their products.

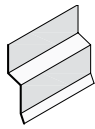
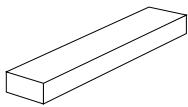
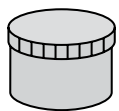
Product	Description
	<b>Building underlay</b> Must comply with Table 23 of E2/AS1.
	<b>Flexible Window Opening Flashing Tape</b> A flexible self-adhesive tape used in preparation of a window. Refer to the window installation section in this manual for more information.  e.g. Protecto or Super Stick by Protecto Wrap or 3M™ All Weather Flashing Tape 8067 by 3M™ Protecto: 0800 776 9727 3M™ 0800 474 787
	<b>James Hardie rigid air barrier Vertical Joint Sealing Tape</b> The tape to be used to seal James Hardie rigid air barrier vertical joints.  Super Stick by Protecto Wrap or 3M™ All Weather Flashing Tape 8067 by 3M™ Protecto: 0800 776 9727 3M™ 0800 474 787
	<b>Flexible Sealant</b> Required to seal the vertical joints. Bostik Seal N Flex-1, Sikaflex AT Facade, Sikaflex MS or similar.
	65 x 2.87mm 'D' head nail or 60 x 2.87 RounDrive nail (hot dipped galvanised/stainless steel) For fixing Stria Cladding.
	40 x 2.8mm or longer HardieFlex™ nail. For fixing timber cavity battens and aluminium flashings.
	<b>Meter Box</b> Refer Electrical Suppliers.
	<b>Head flashing</b> Required over window heads to be supplied by window installer. Material must comply with Table 20 and 21 of E2/AS1.
	<b>Timber cavity batten</b> H3.1 minimum treated Timber cavity batten the cladding is fixed over.
	<b>Exterior grade filler</b> CRC Builders Fill or similar two part filler to fill over nail holes

# 13 Details

The following generic details have been provided in this document for cavity construction methods.

Table 5

Details		
Description	Cavity Construction	
	Figure No.	Page No.
Framing set out	Figure 1	13
Batten fixing set out	Figure 2	14
Stria Cladding layout	Figure 3	15
Foundation detail – option 1	Figure 4	15
Foundation detail – option 2	Figure 5	16
Soffit detail	Figure 6	16
Vertical trimline joint flashing option	Figure 7	17
Vertical trimline joint flashing option	Figure 8	18
Vertical joint flashing option	Figure 9	19
Vertical joint flashing option	Figure 10	20
Vertical butt joint option	Figure 11	21
Fixing detail	Figure 12	22
External aluminium box corner	Figure 13	23
External aluminium box corner (Alternative)	Figure 14	23
Internal aluminium corner	Figure 15	24
Internal mitred corner	Figure 16	24
Window sill	Figure 17	25
Window jamb	Figure 18	25
Window head	Figure 19	26
Stria cutting around sill	Figure 20	27
Stria cutting around head	Figure 21	27
Window head	Figure 22	28
Window head to Stria Cladding cut board	Figure 23	28
Window head	Figure 24	29
Trimline Horizontal joint at floor joist	Figure 25	30
Drained flashing joint at floor level	Figure 26	31
Drained flashing joint at floor joist	Figure 27	32
Engineered floor joist	Figure 28	33
Apron flashing detail	Figure 29	33
Parapet flashing	Figure 30	34
Roof to wall junction detail	Figure 31	34
Meter box at sill	Figure 32	35
Meter box at jamb	Figure 33	35
Meter box at head	Figure 34	36
Enclosed deck	Figure 35	36

Figure 1: Framing set out

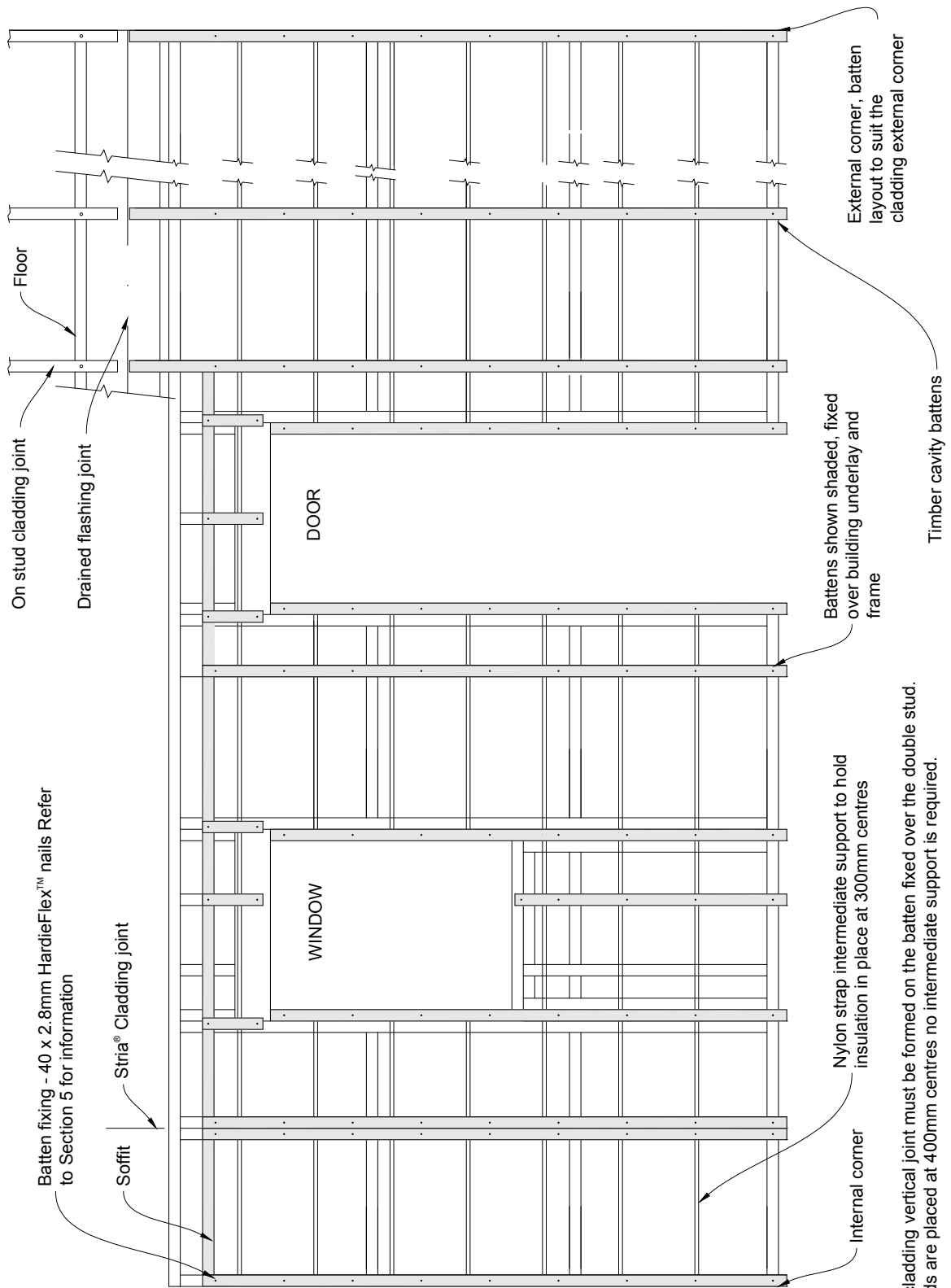

Batten fixing - 40 x 2.8mm HardieFlex™ nails Refer to Section 5 for information

Stria® Cladding joint

Soffit

- The cladding vertical joint must be formed on the batten fixed over the double stud.
- If studs are placed at 400mm centres no intermediate support is required.



Figure 2: Batten fixing set out

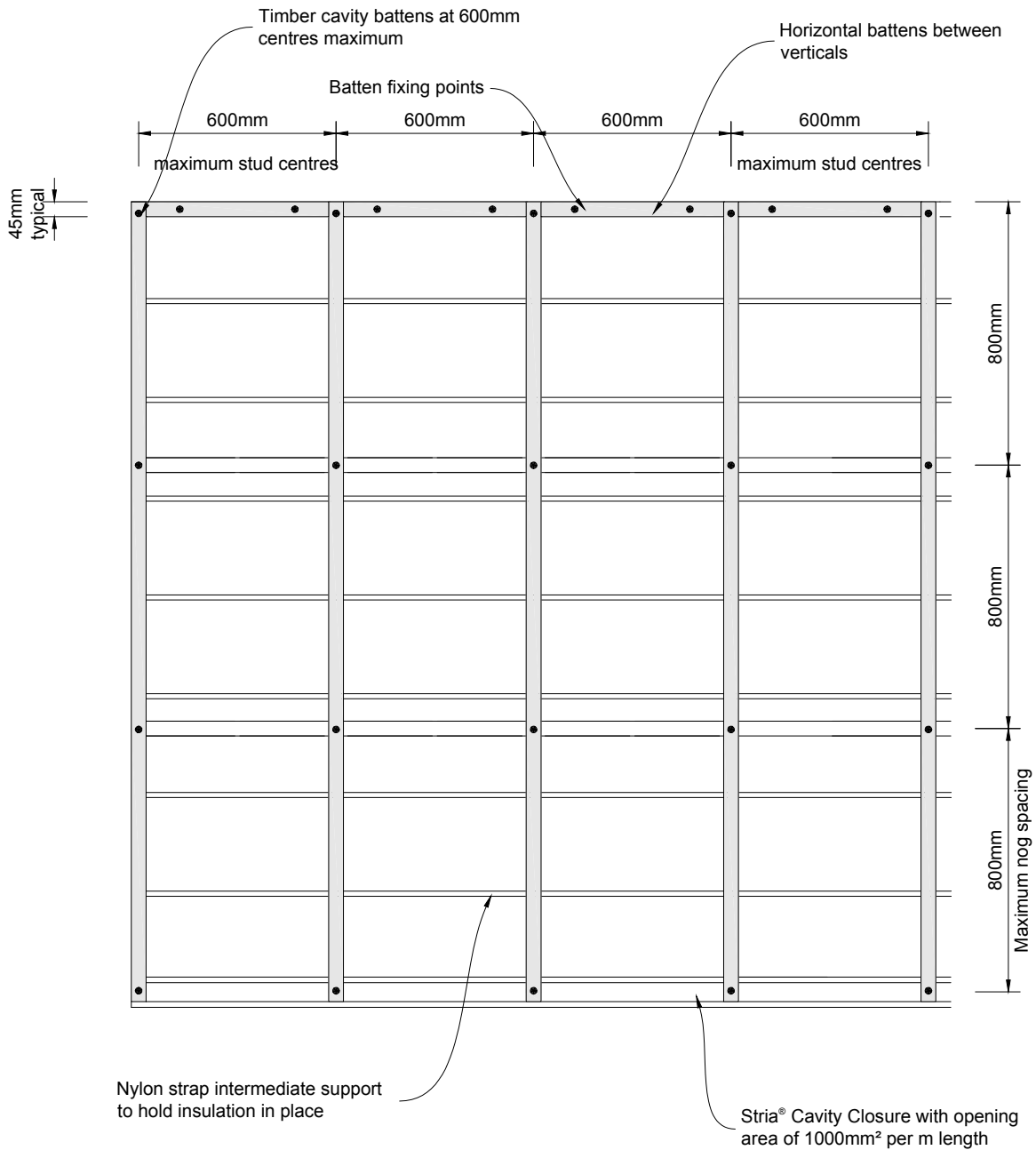
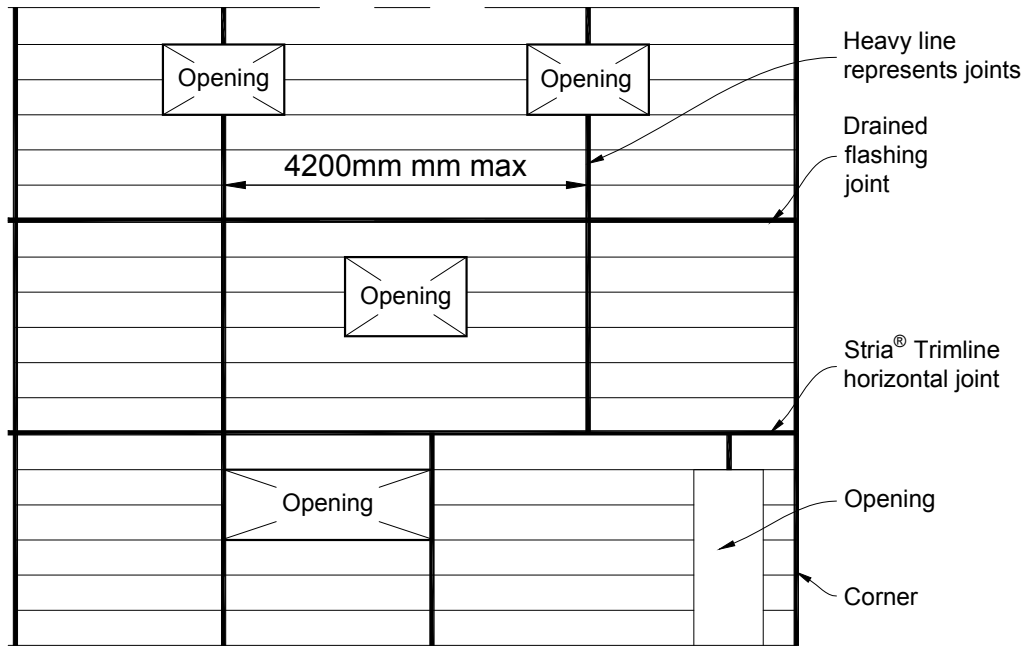

Figure 3: Stria Cladding layout



Typical Storey Layout

Figure 4: Foundation detail – option 1

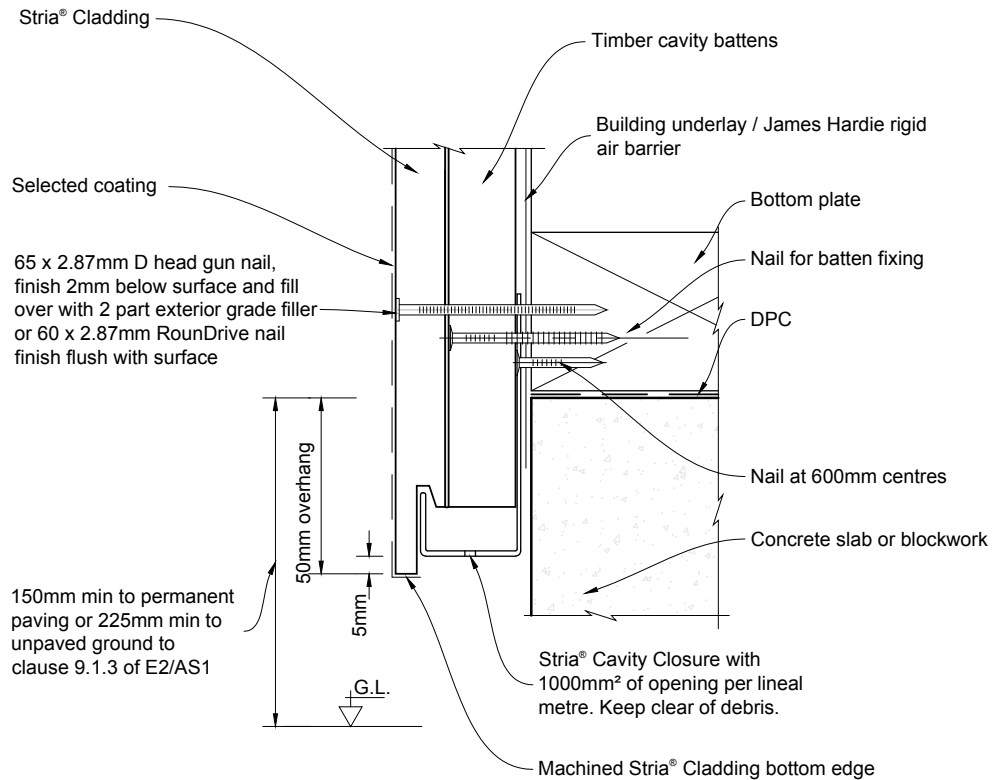

Figure 5: Foundation detail – option 2

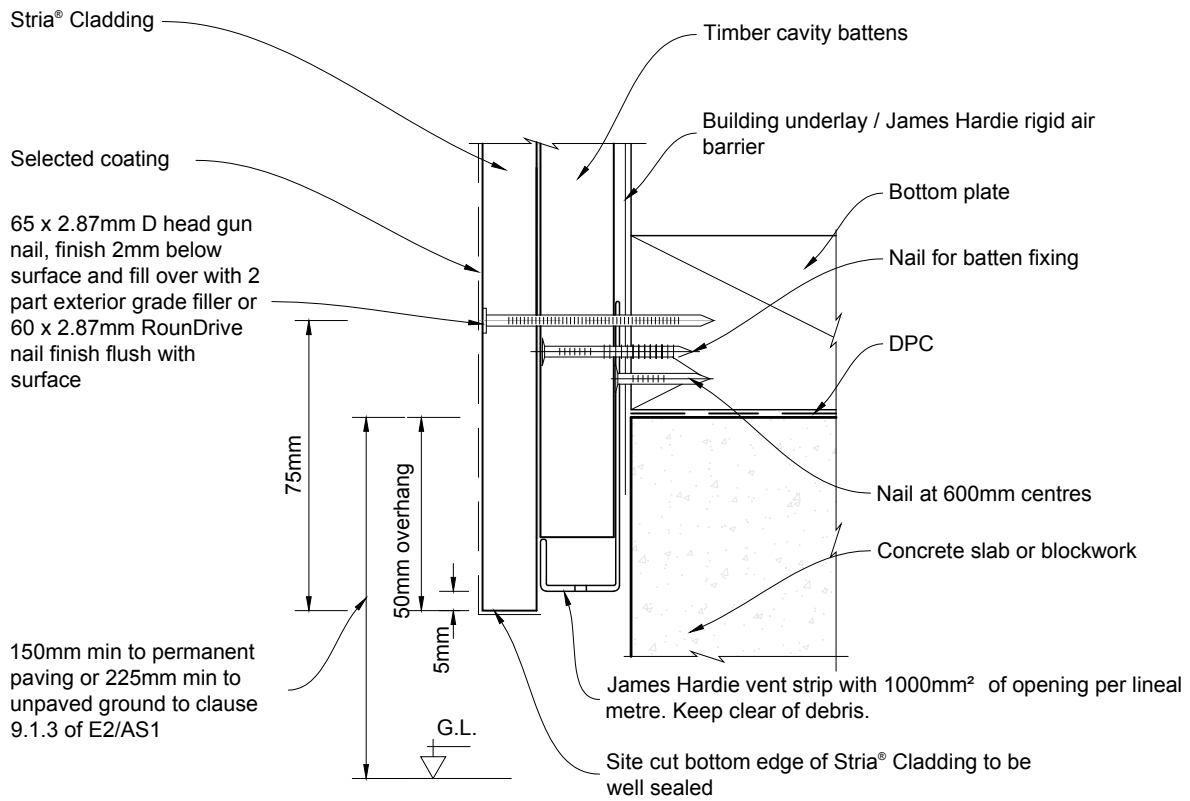

Figure 6: Soffit detail

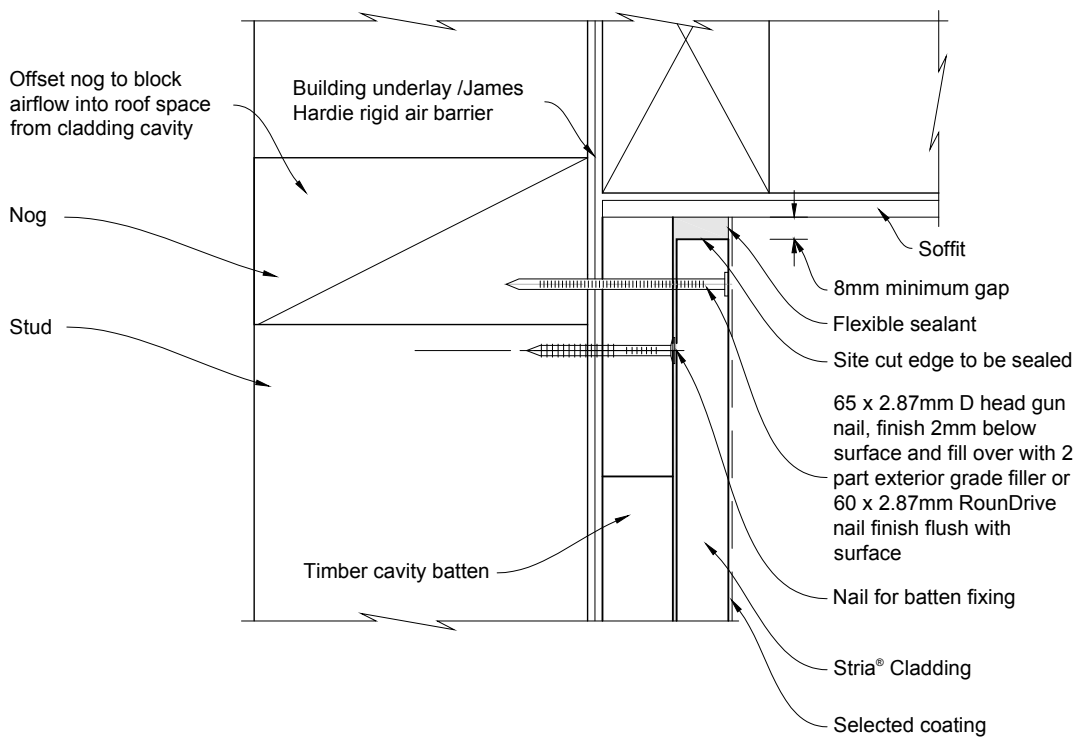
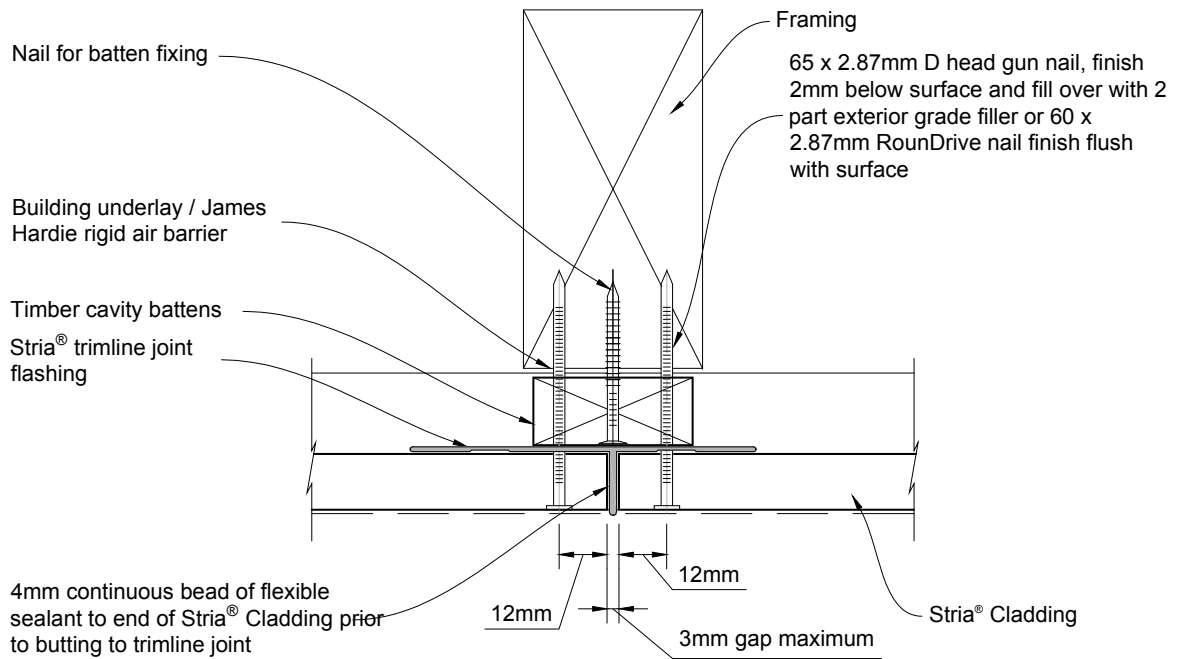

Figure 7: Vertical trimline joint flashing option



**Note:** All site cut edges to be sealed

Figure 8: Vertical trimline joint flashing option

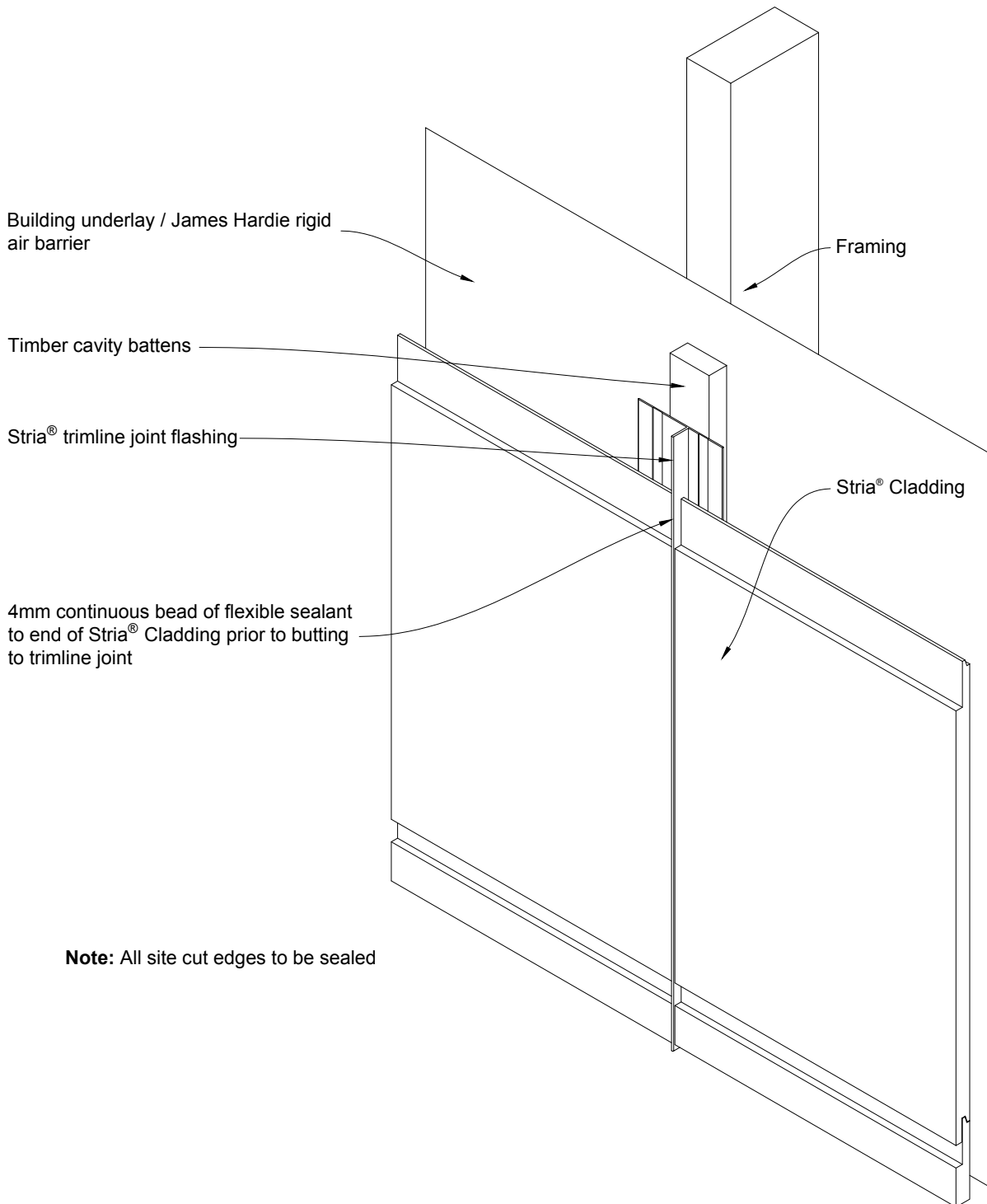



Figure 9: Vertical joint flashing option

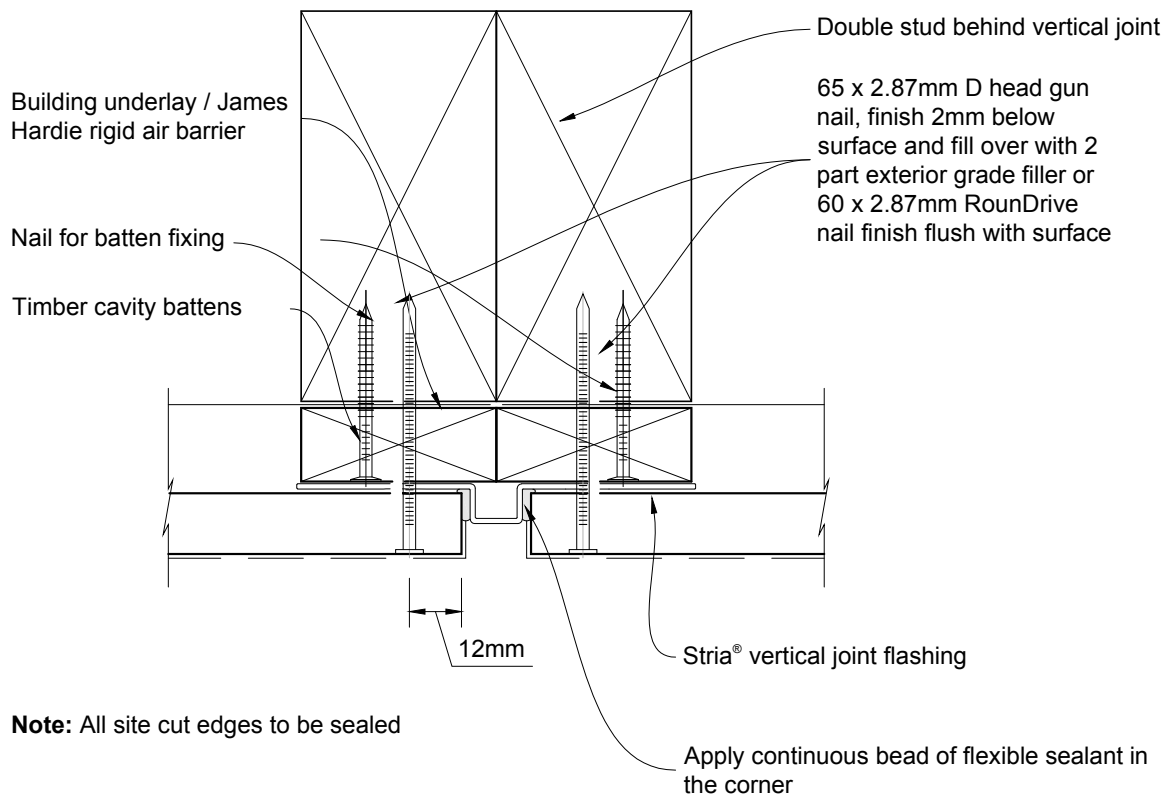
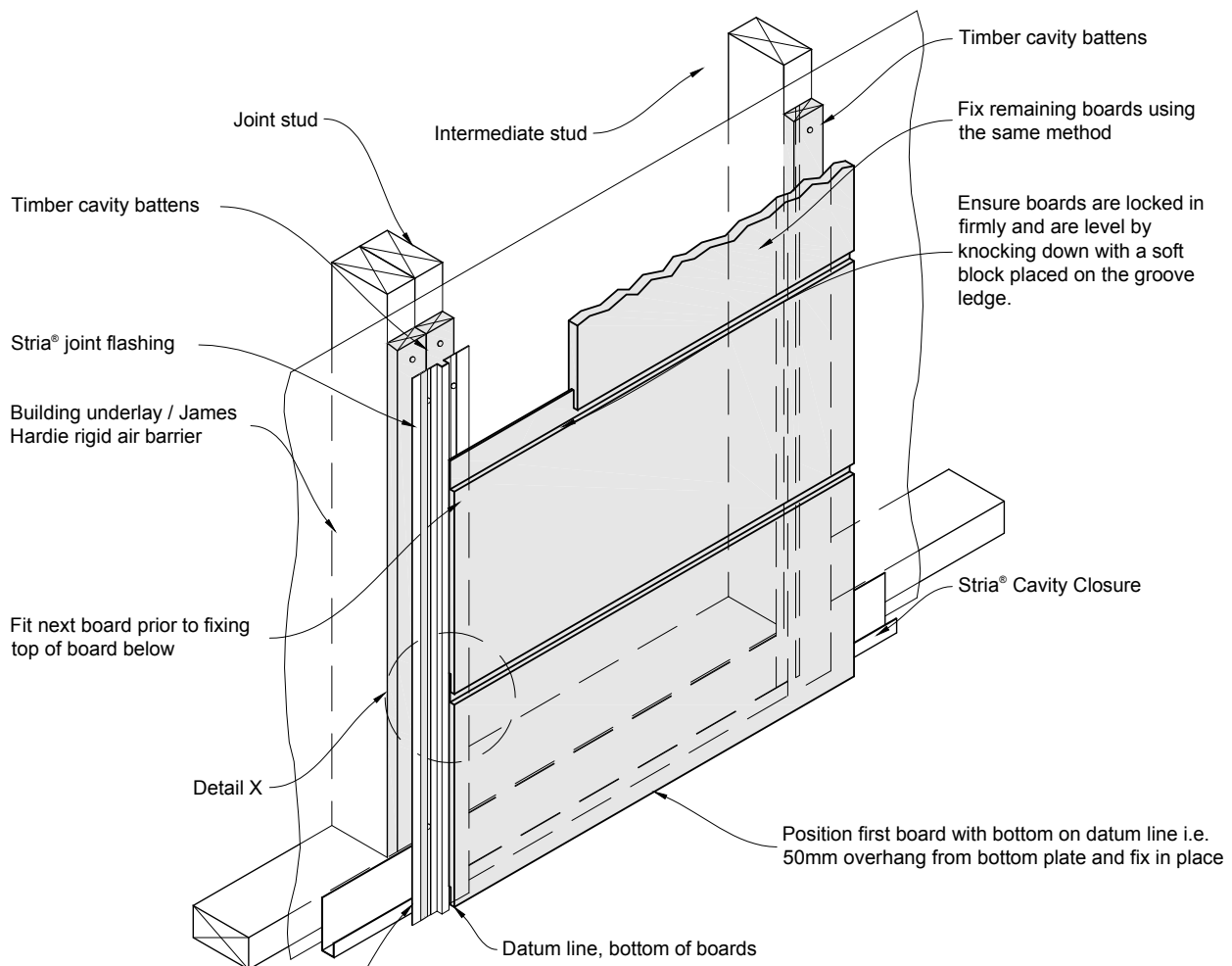
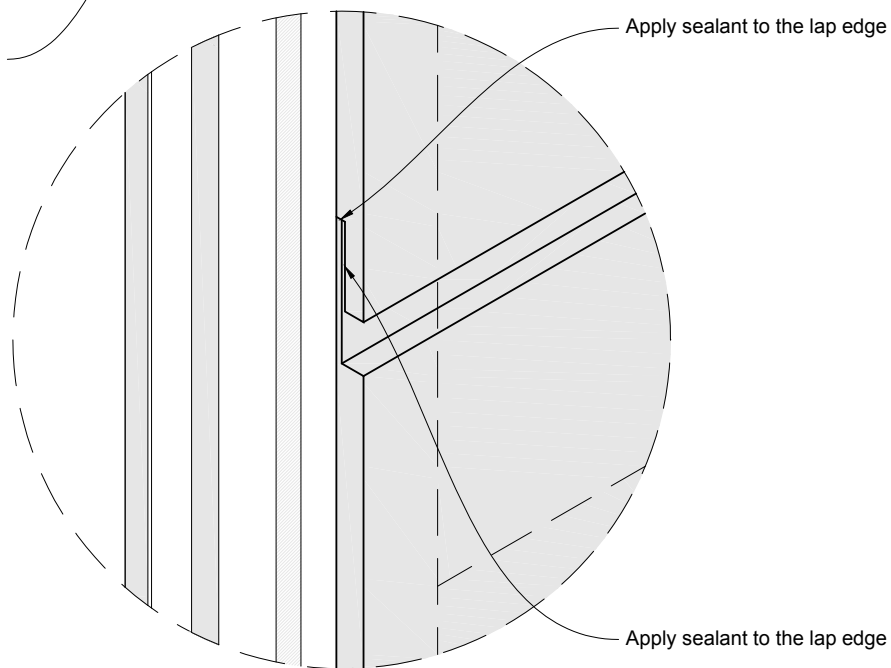

Figure 10: Vertical joint flashing option



Remove face of cavity closure only behind Stria joint flashing



**Note:** All site cut edges to be sealed

Figure 11: Vertical butt joint option

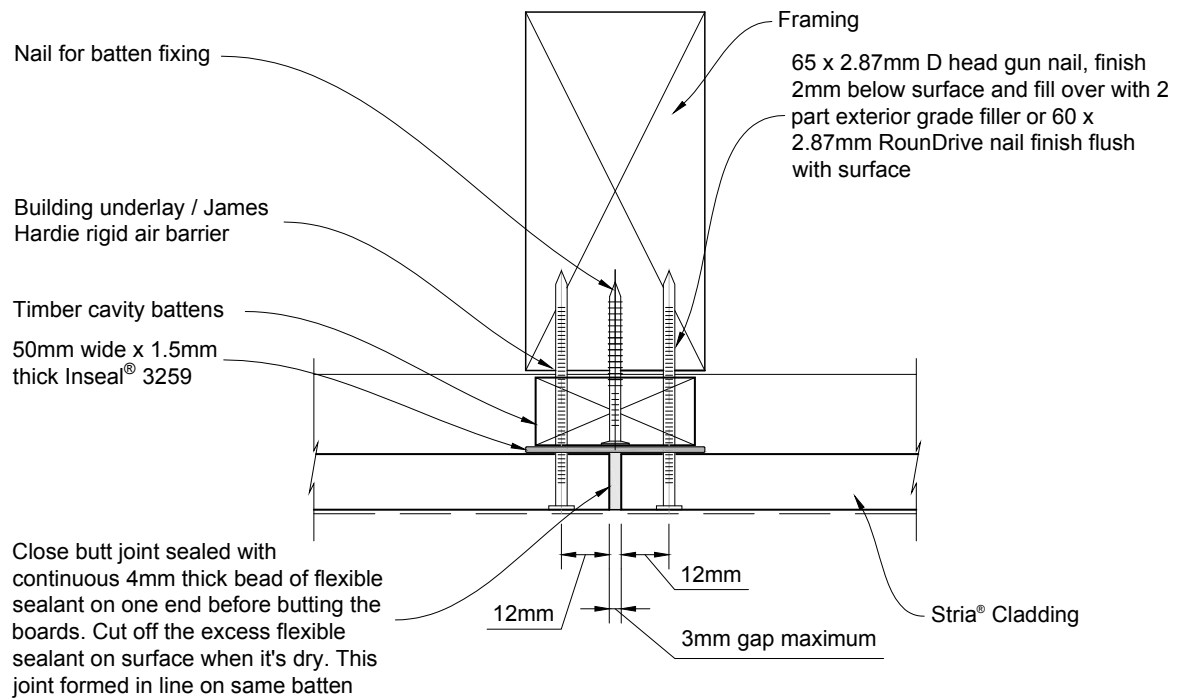

**Note:** All site cut edges to be sealed

Figure 12: Fixing detail

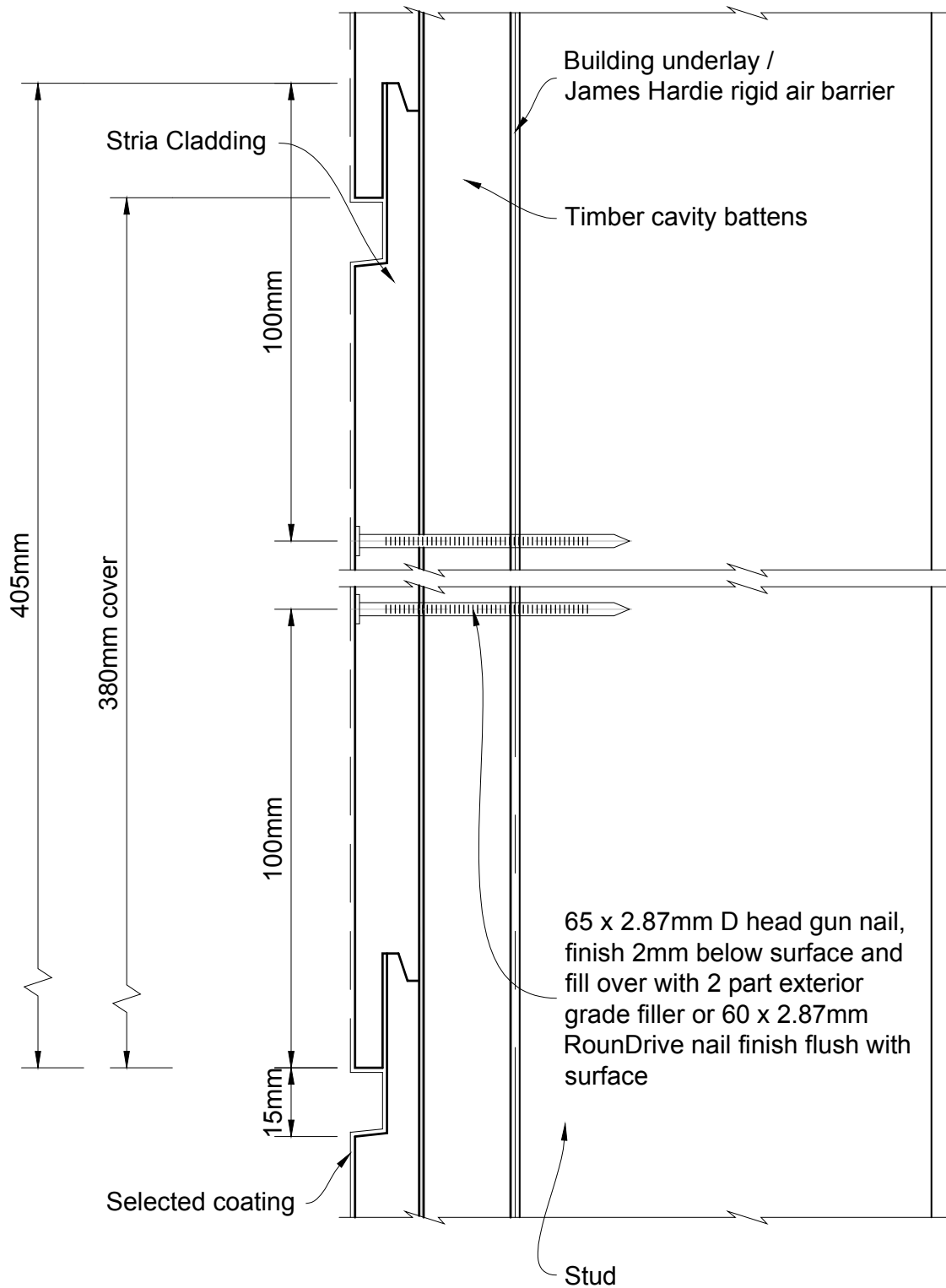

Figure 13: External aluminium box corner

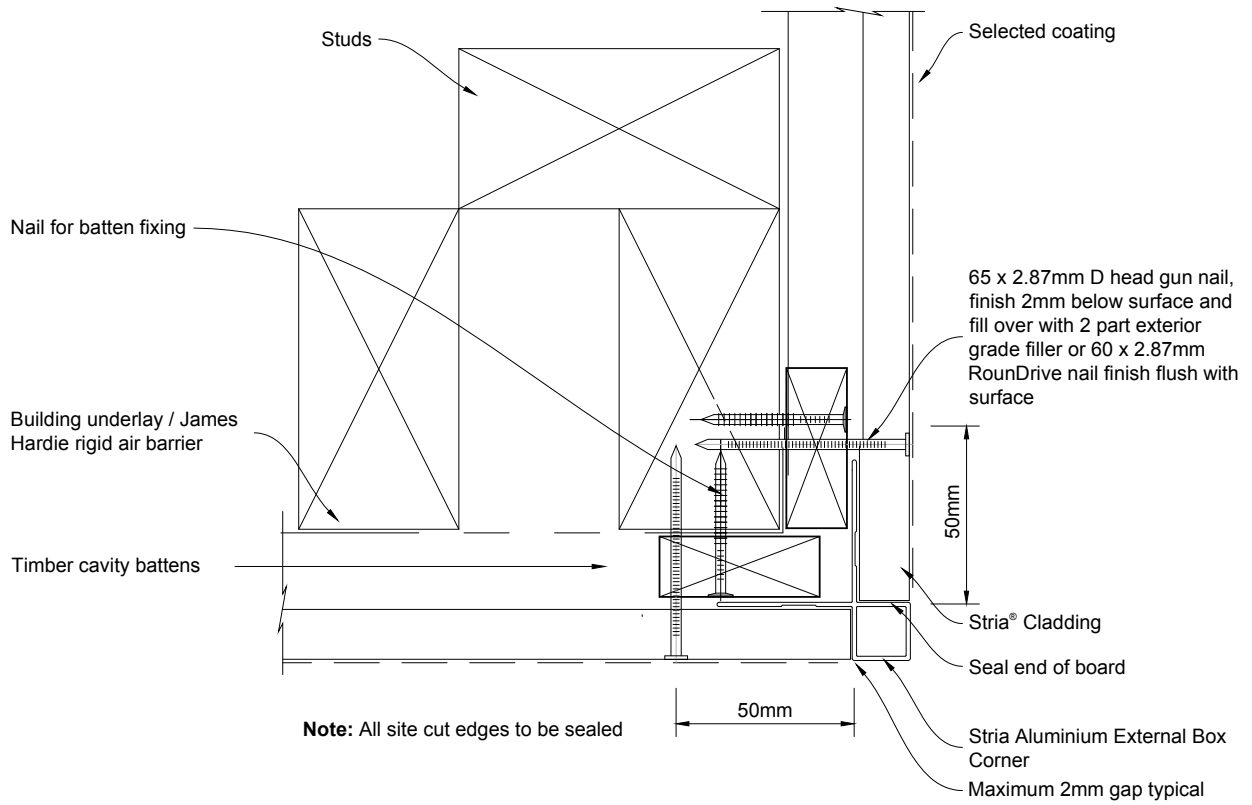

Figure 14: External aluminium box corner (Alternative)

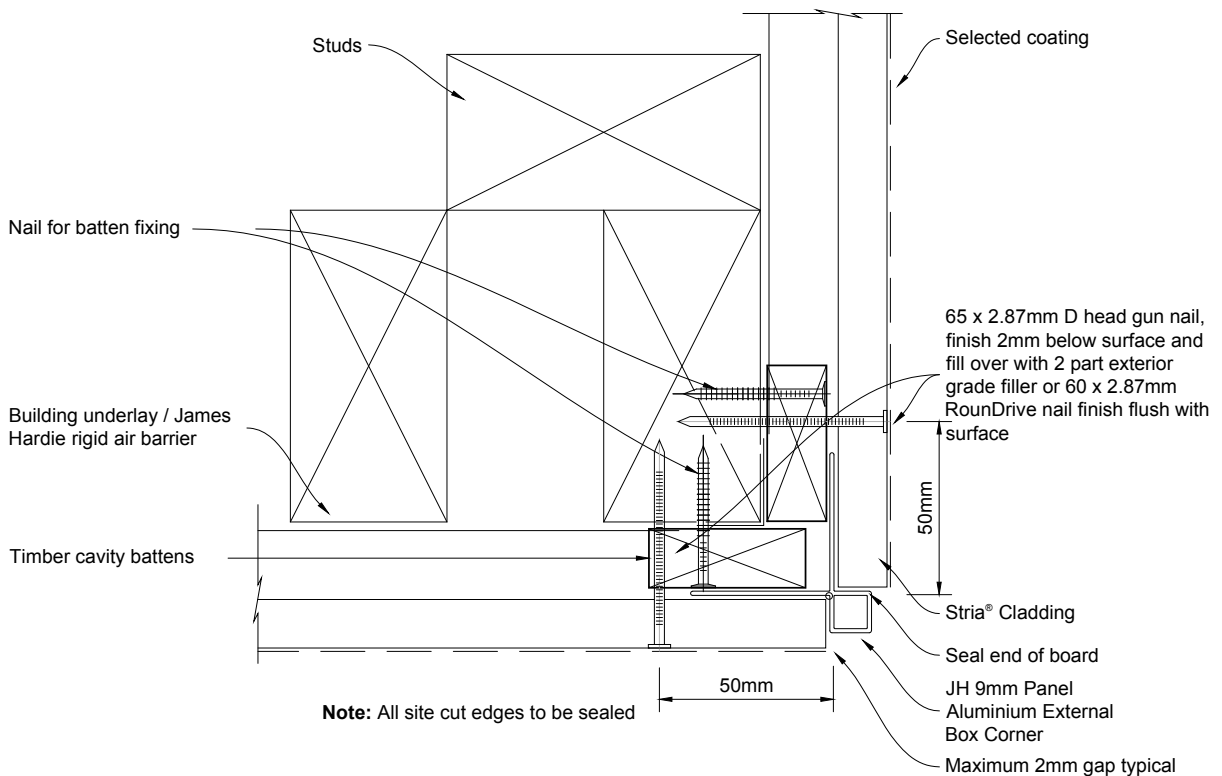



Figure 15: Internal aluminium corner

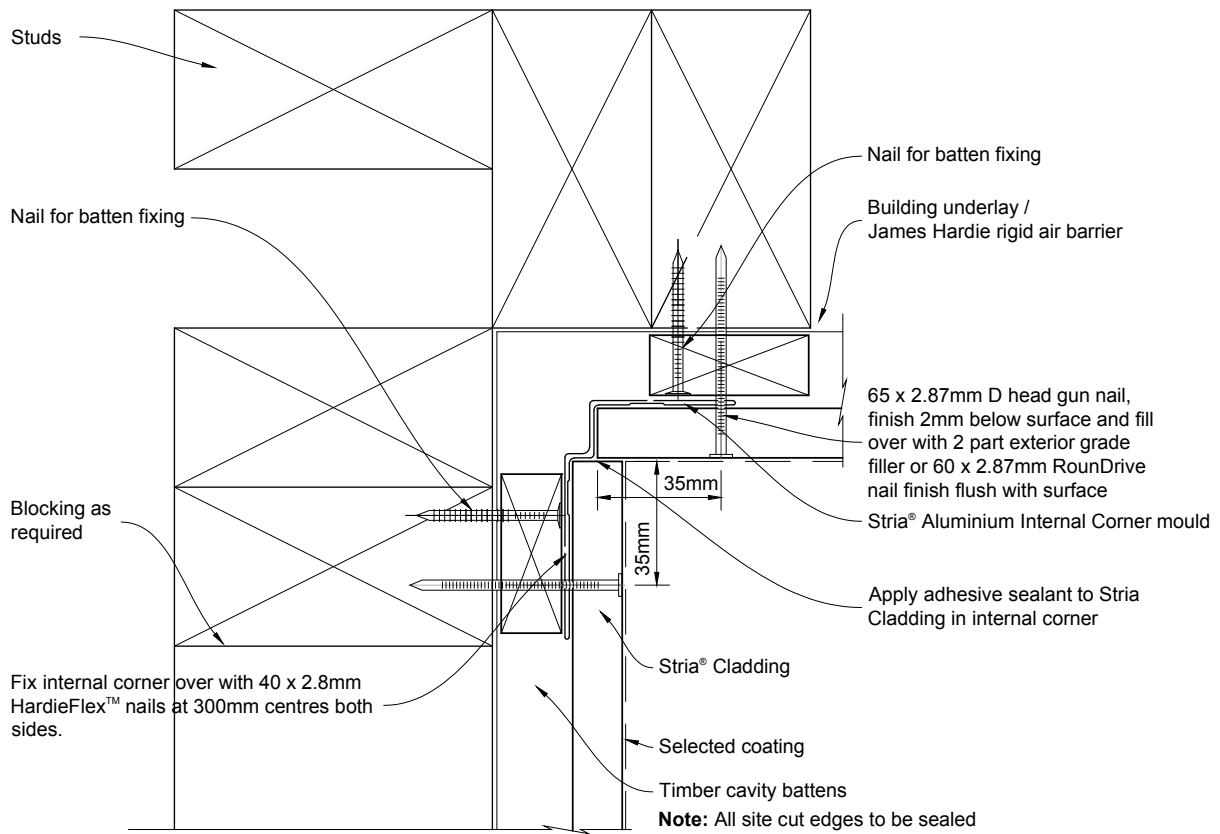

Figure 16: Internal mitred corner

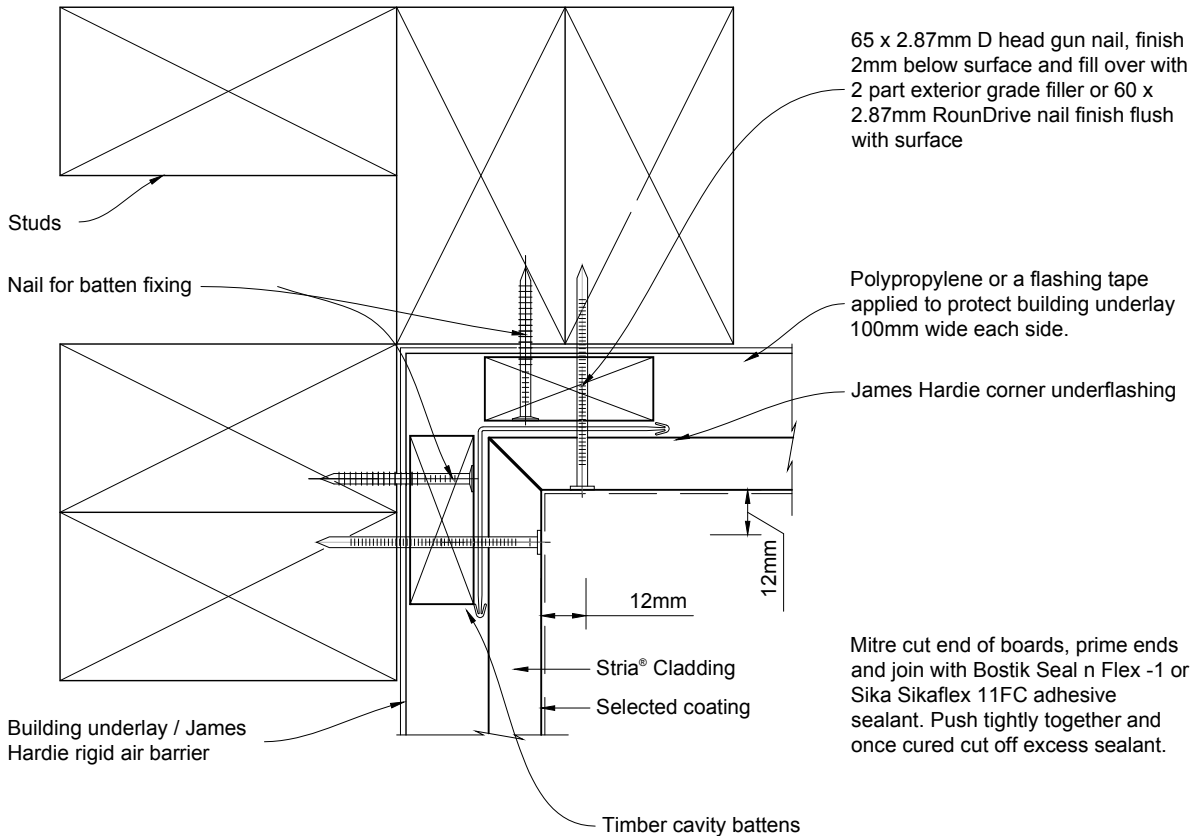
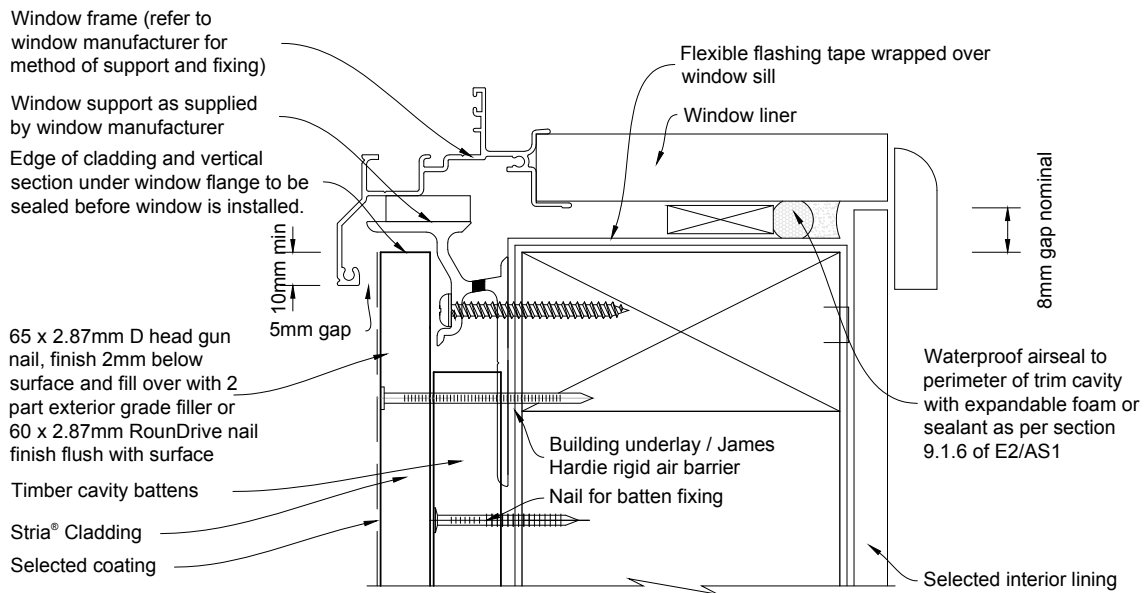

Figure 17: Window sill



General notes for materials selection

1. Flashing materials must be selected based on environmental exposure, refer to NZS 3604 and Table 20 of NZBC E2/AS1.
  2. Building underlay must comply with acceptable solution E2/AS1 and NZS 3604
  3. Flashing tape must have proven compatibility with the selected building underlay and other materials with which it comes into contact as per Table 21 of E2/AS1.
  4. When James Hardie rigid air barriers are used flashing tape to be applied to the entire opening.
- Refer to the manufacturer or supplier for technical information for these materials.

Figure 18: Window jamb

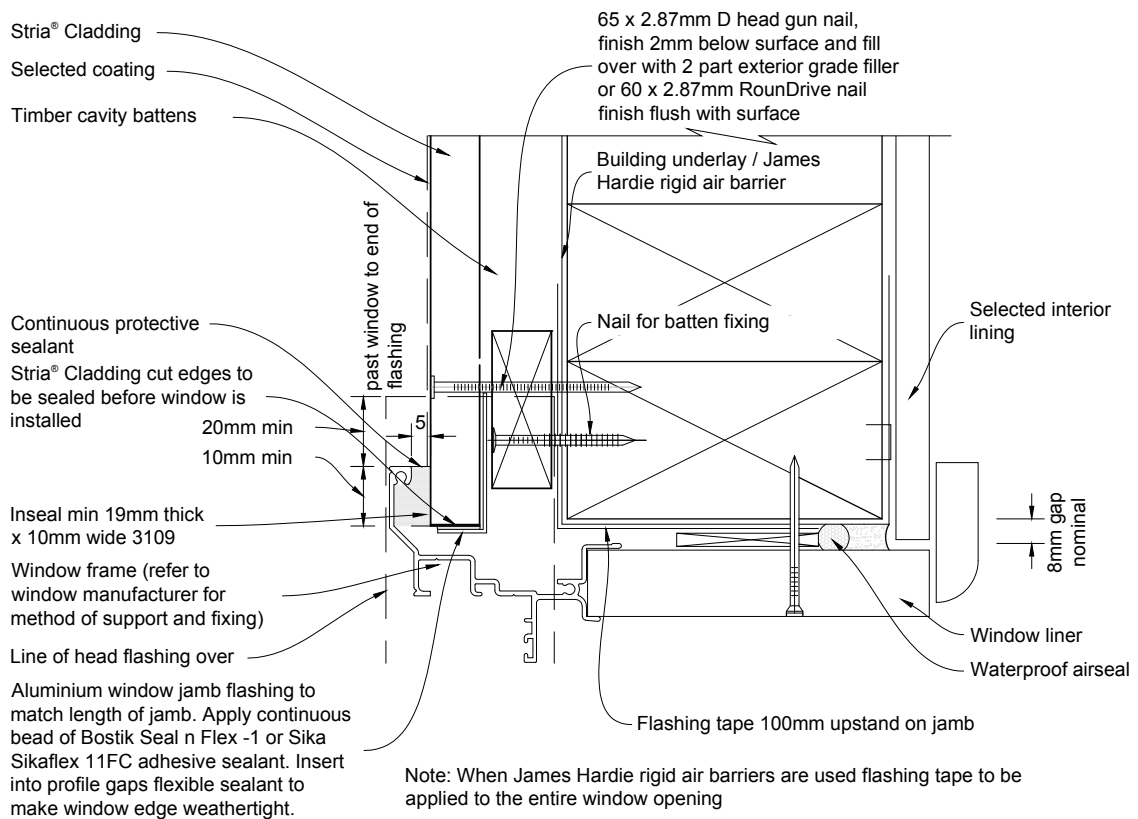

Note: When James Hardie rigid air barriers are used flashing tape to be applied to the entire window opening

Figure 19: Window head

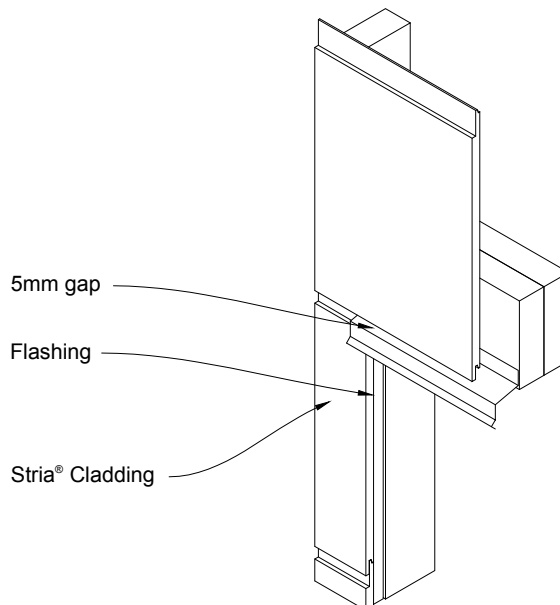
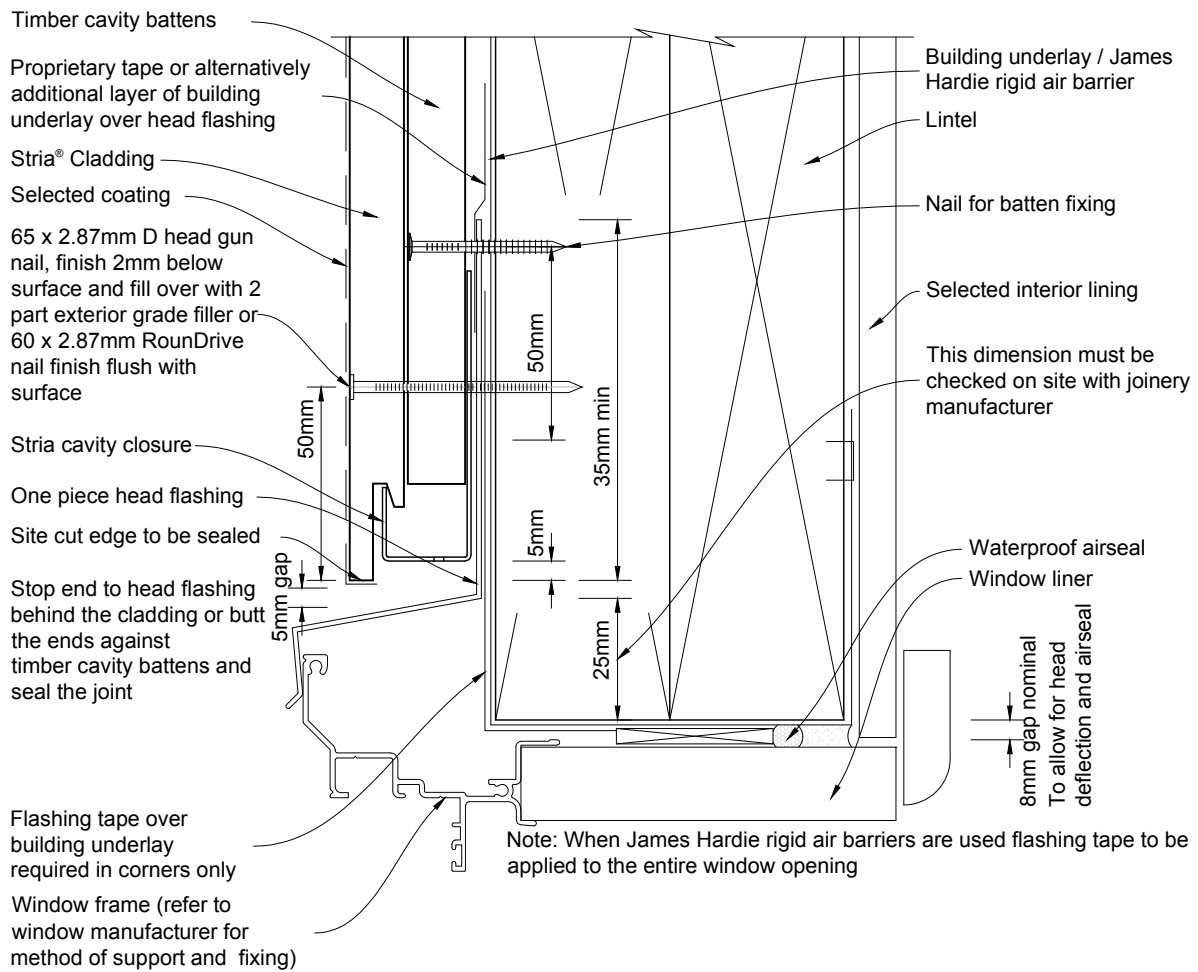

Figure 20: Stria cutting around sill

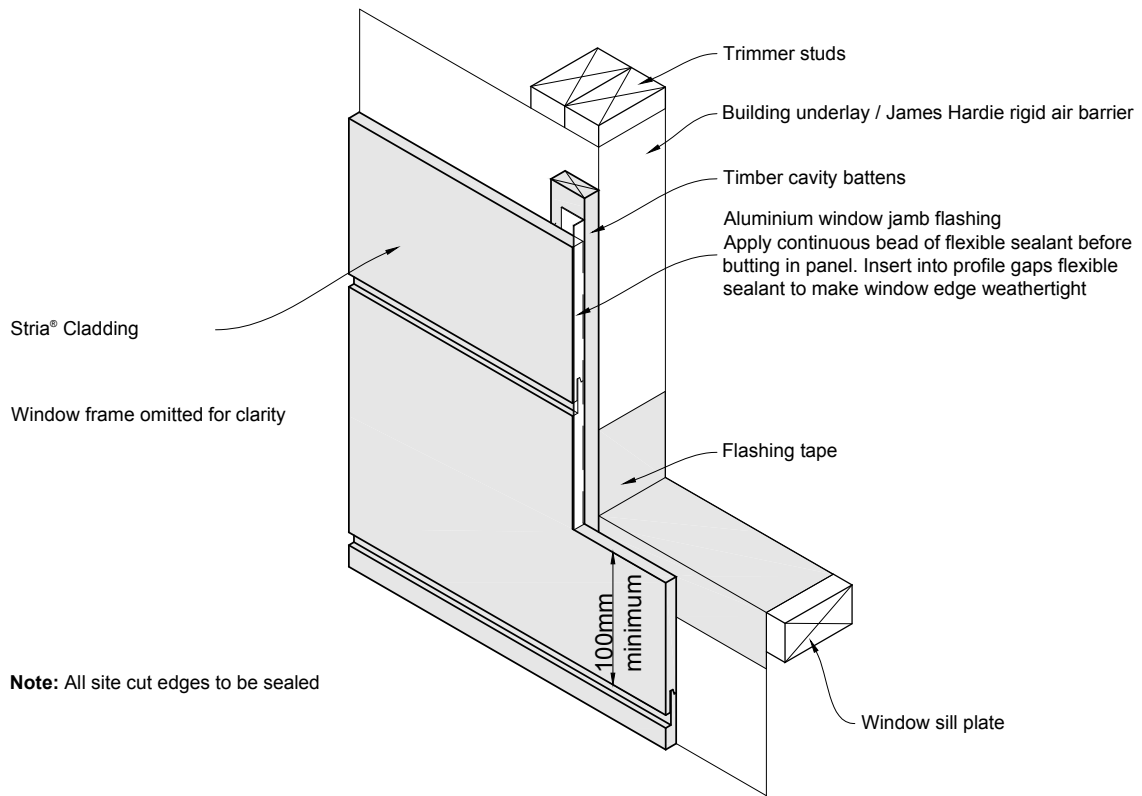

Figure 21: Stria cutting around head

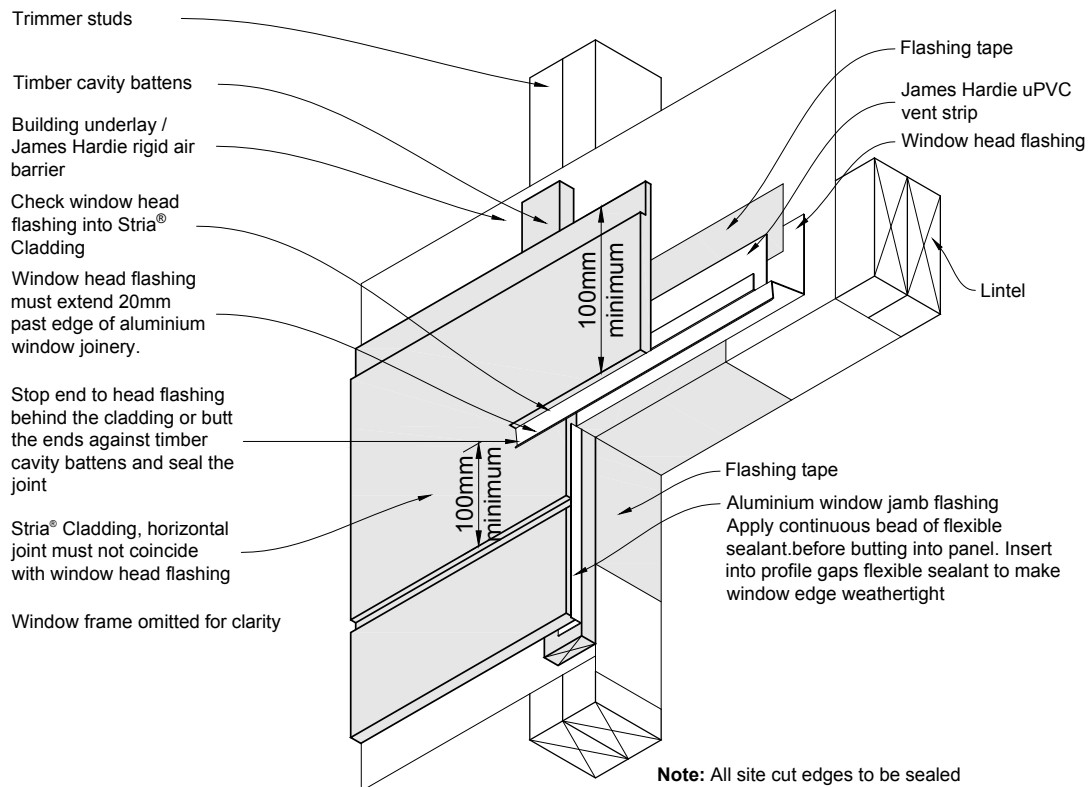

Figure 22: Window head

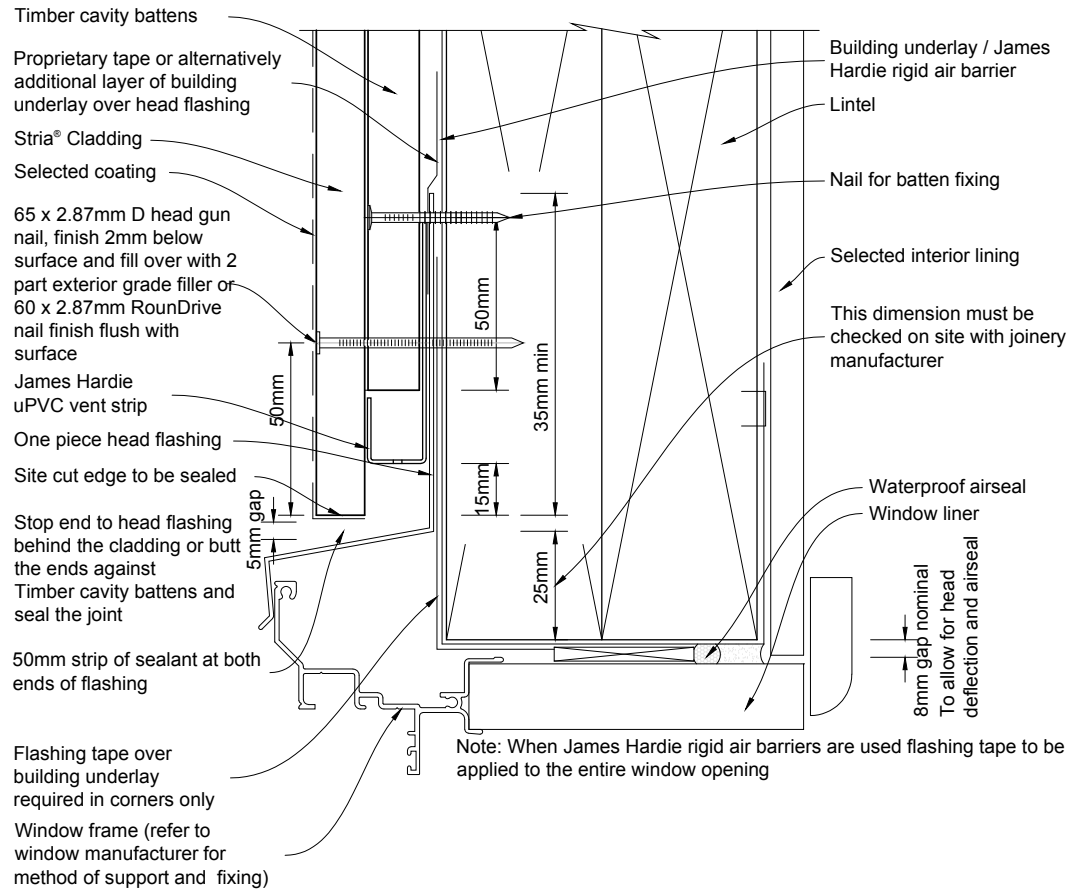

Figure 23: Window head to Stria Cladding cut board

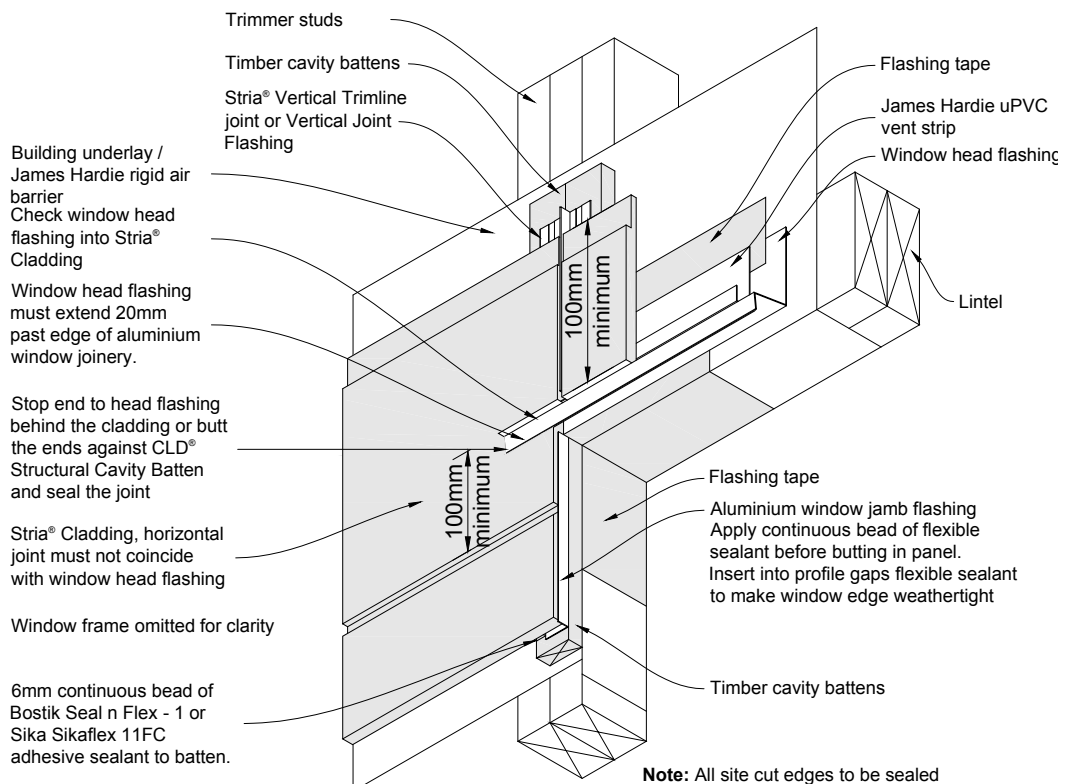

Figure 24: Window head

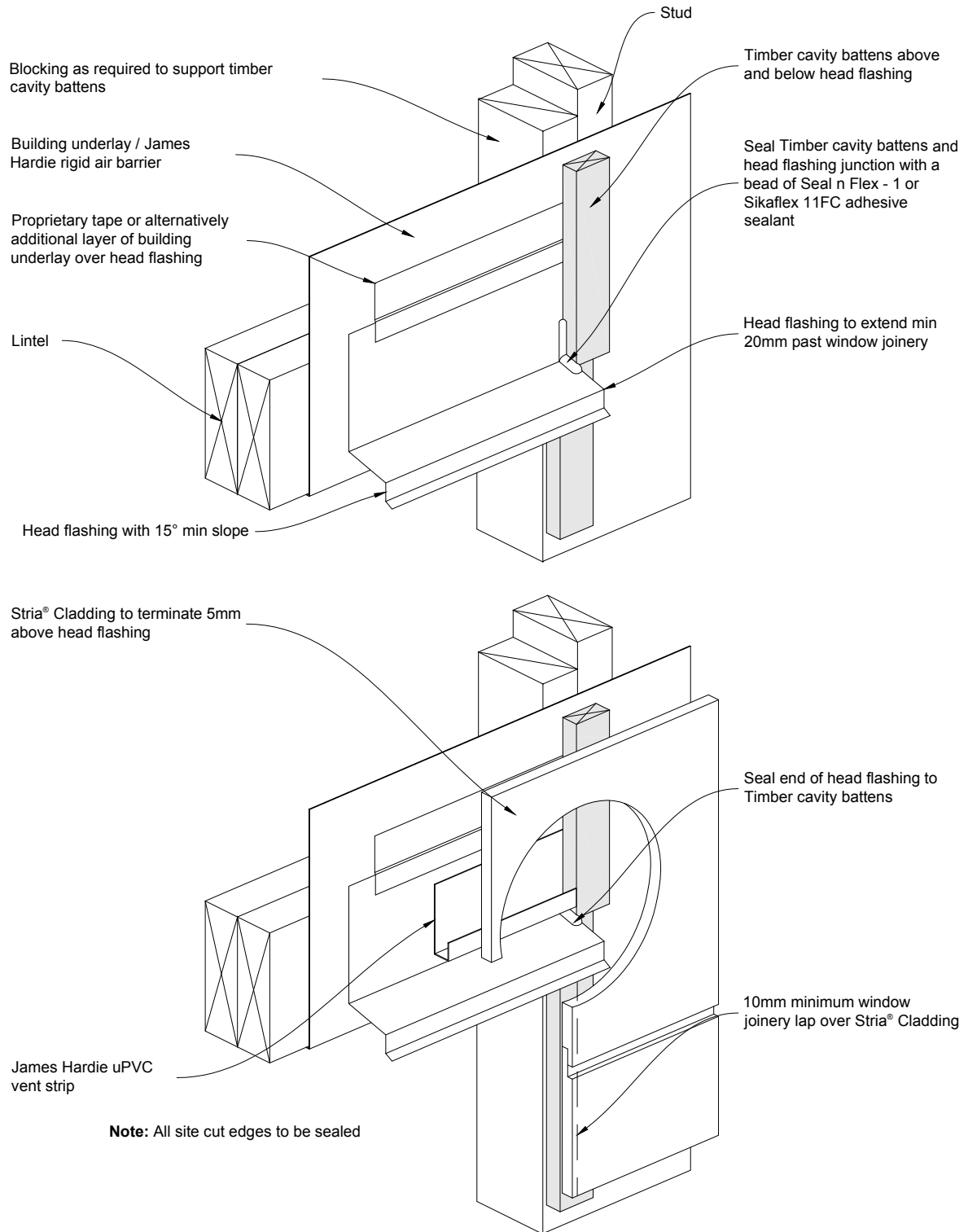
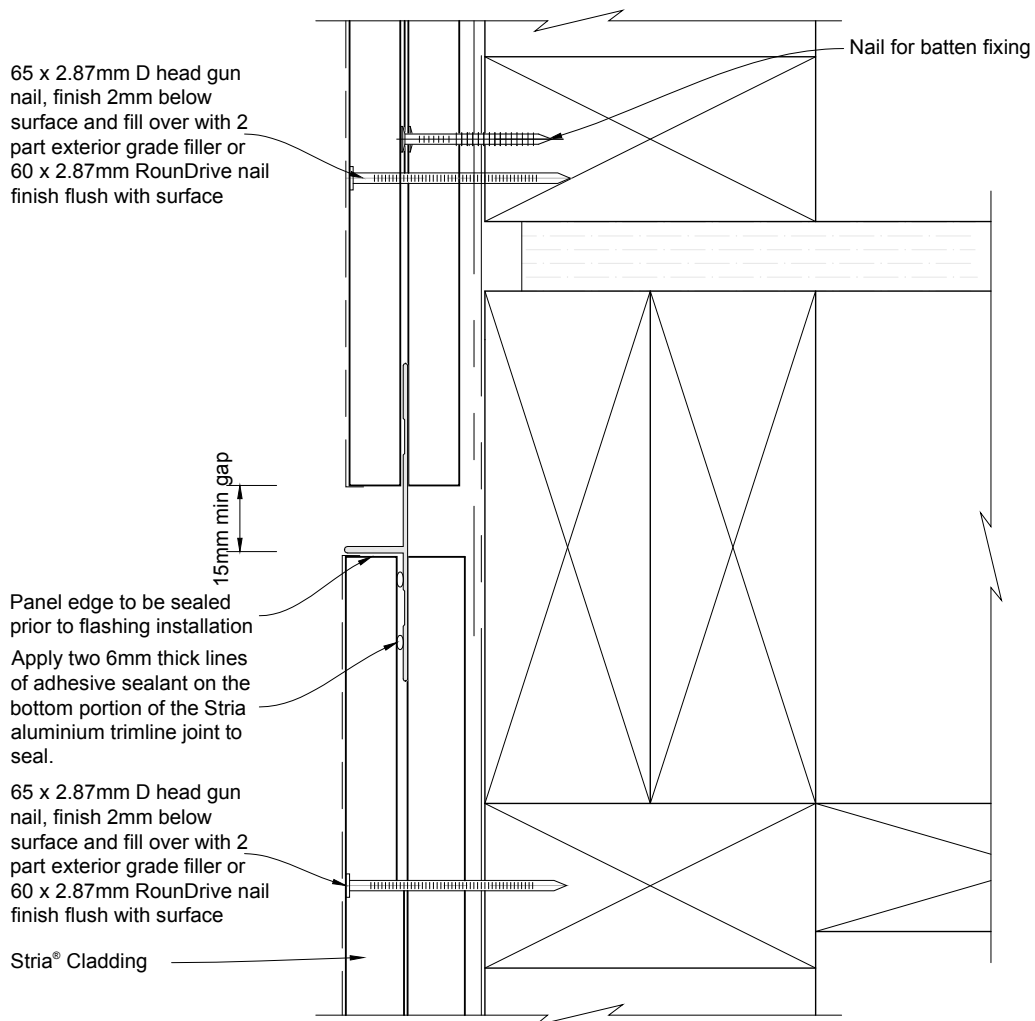

Figure 25: Trimline horizontal joint at floor joists



**STEP 1**

- Check architects plans for the type of flashing to be used.

**STEP 2**

- Check fixing centres and edge distances.

**STEP 3**

- When 50 year durability is required refer Table 20 E2/AS1.

**STEP 4**

- The flashing to be placed in the centre of the floor joists. Do not fix timber cavity battens or cladding into floor joists.

**Notes:**

- Stria aluminium trimline joint, take care to ensure continuous seal is formed between panel and the trimline joint.
- A purpose made 100mm long x 16mm deep x 0.7mm thick 'L' shaped flashing will be required over the butt joint of the Stria aluminium trimline joint.

Figure 26: Drained flashing joint at floor level

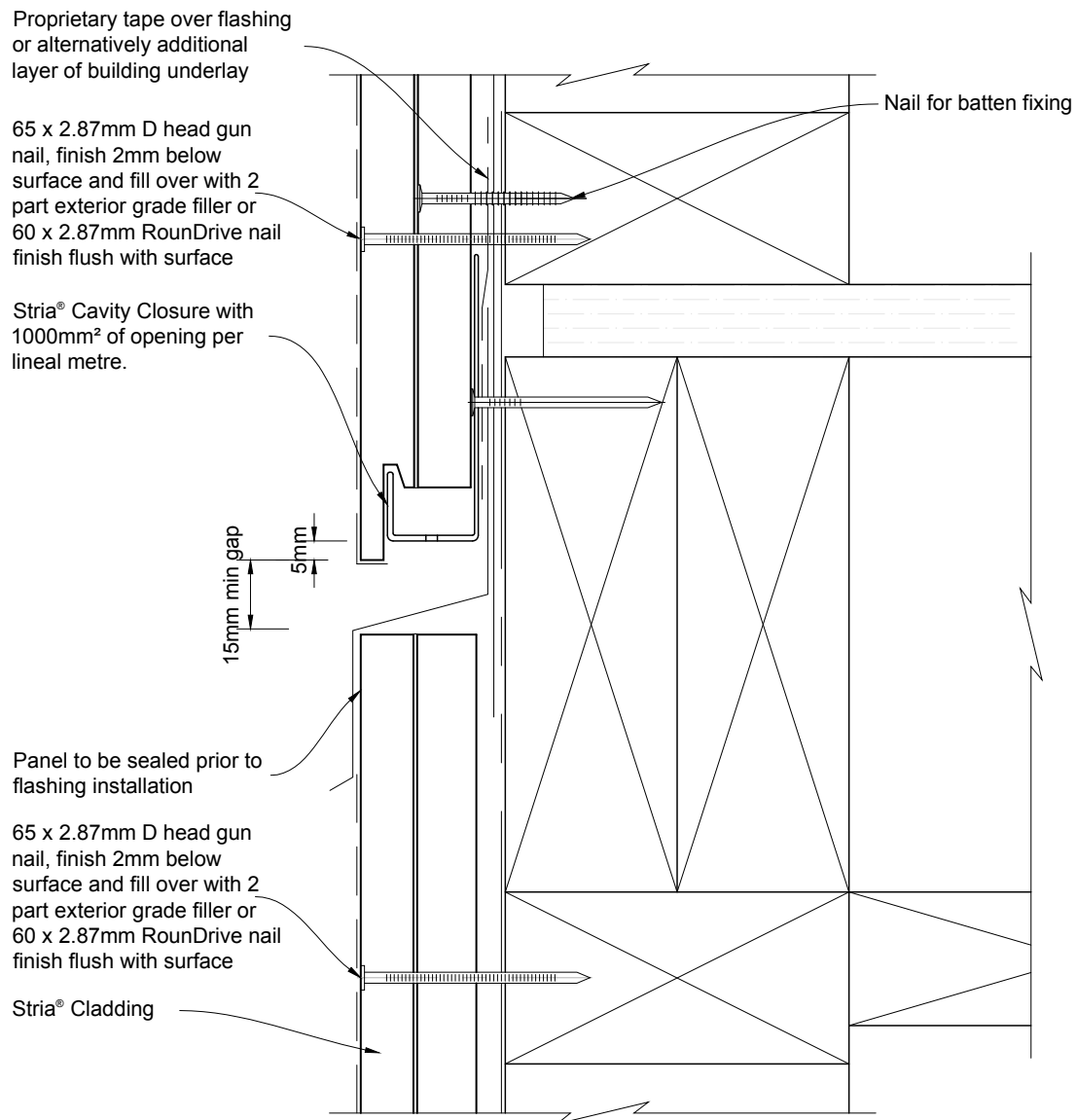

STEP 1

- Check architects plans for the type of flashing to be used.

STEP 2

- Check fixing centres and edge distances.
- If top fixings are to be hidden by the Z flashing they will need to be fixed and sealed before the Z flashing is installed.

STEP 3

- When 50 year durability is required refer Table 20 E2/AS1.

STEP 4

- The flashing to be placed in the centre of the floor joists. Do not fix timber cavity battens or cladding into floor joists.

*Note: This detail is required to limit cavities to a maximum of 2 stories or 7 metres. Refer to E2/AS1 clause 9.1.9.4*



Figure 27: Drained flashing joint at floor joist

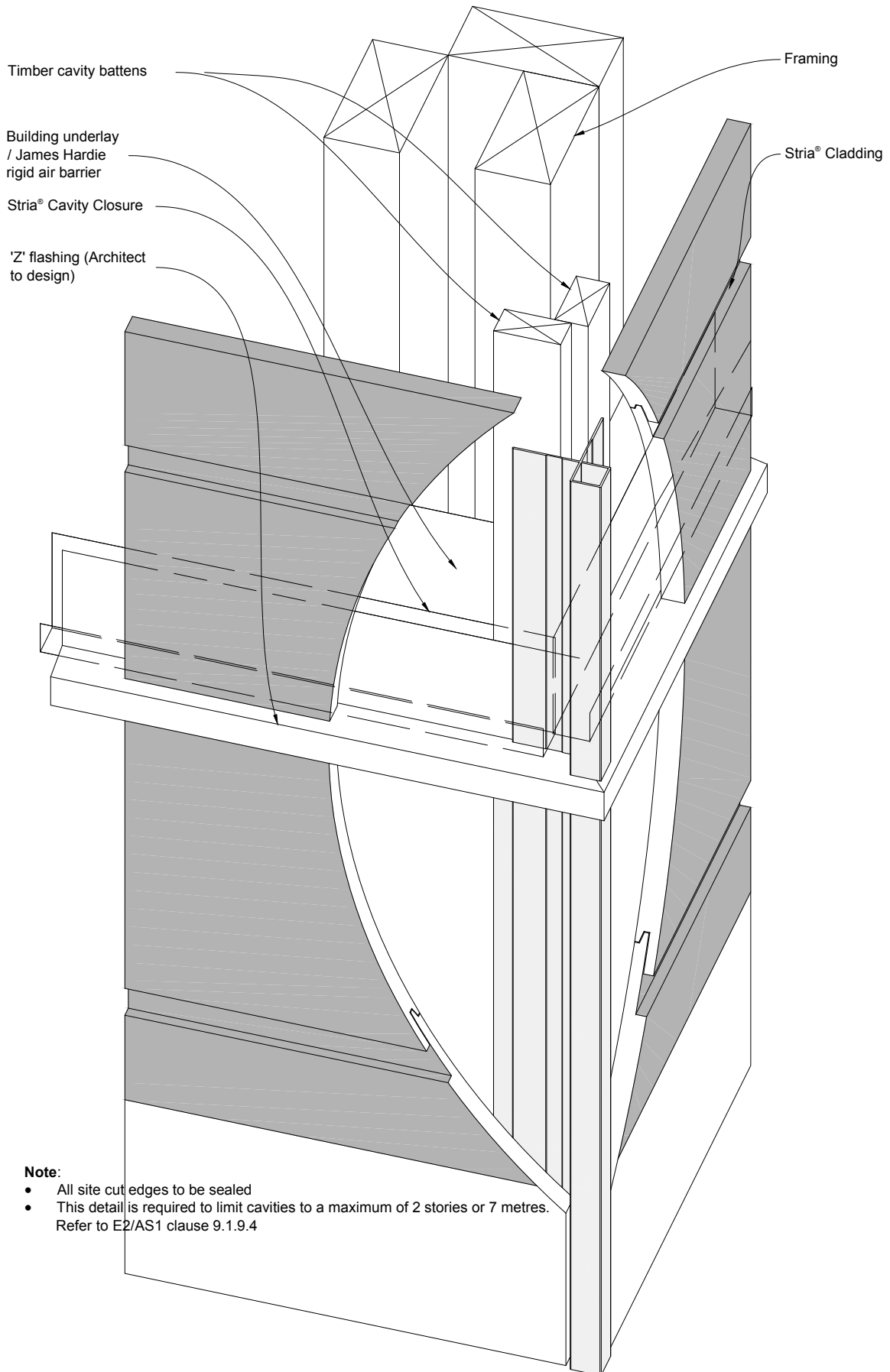

**Note:**

- All site cut edges to be sealed
- This detail is required to limit cavities to a maximum of 2 stories or 7 metres. Refer to E2/AS1 clause 9.1.9.4

Figure 28: Engineered floor joist

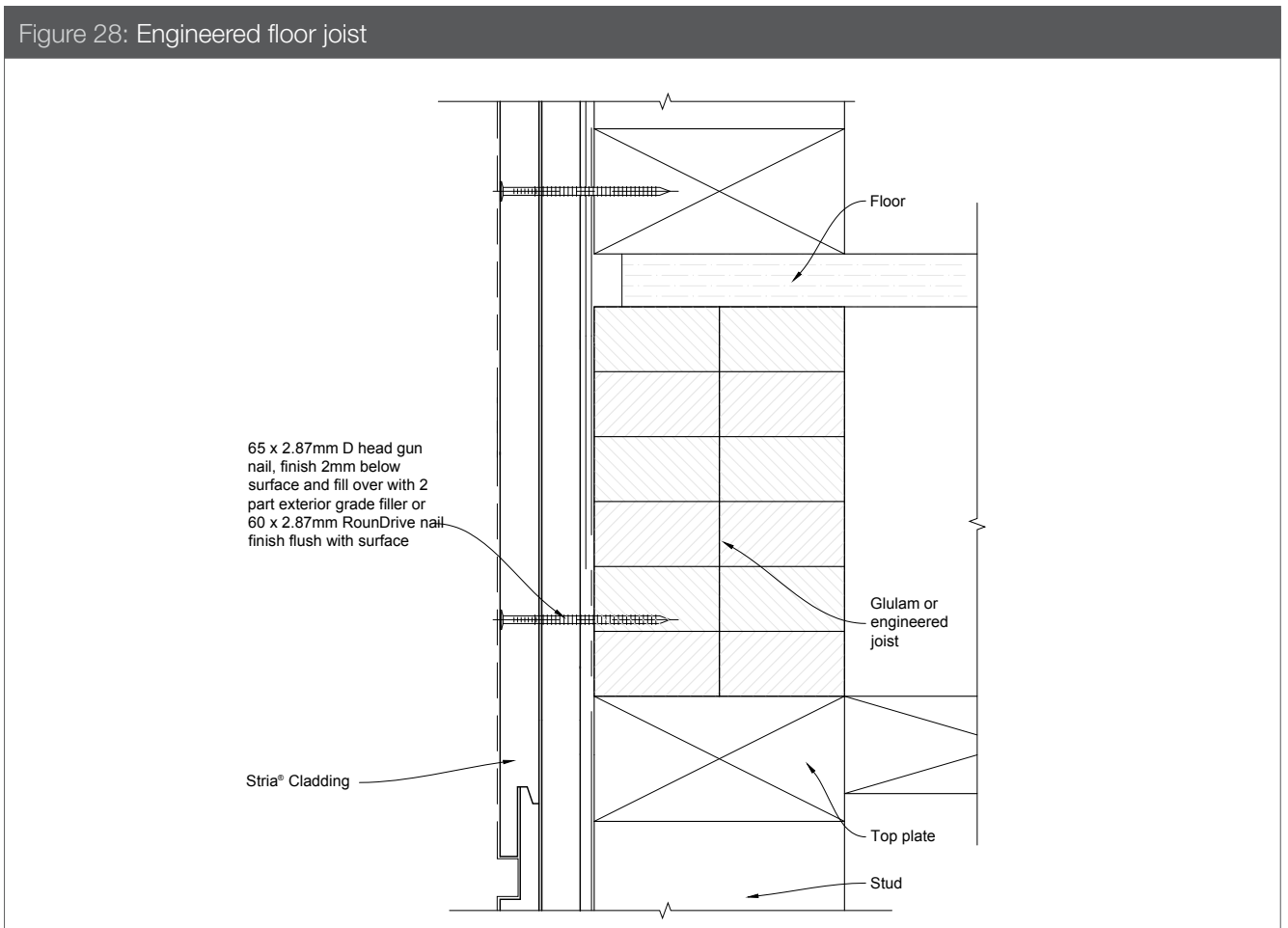

Figure 29: Apron flashing detail

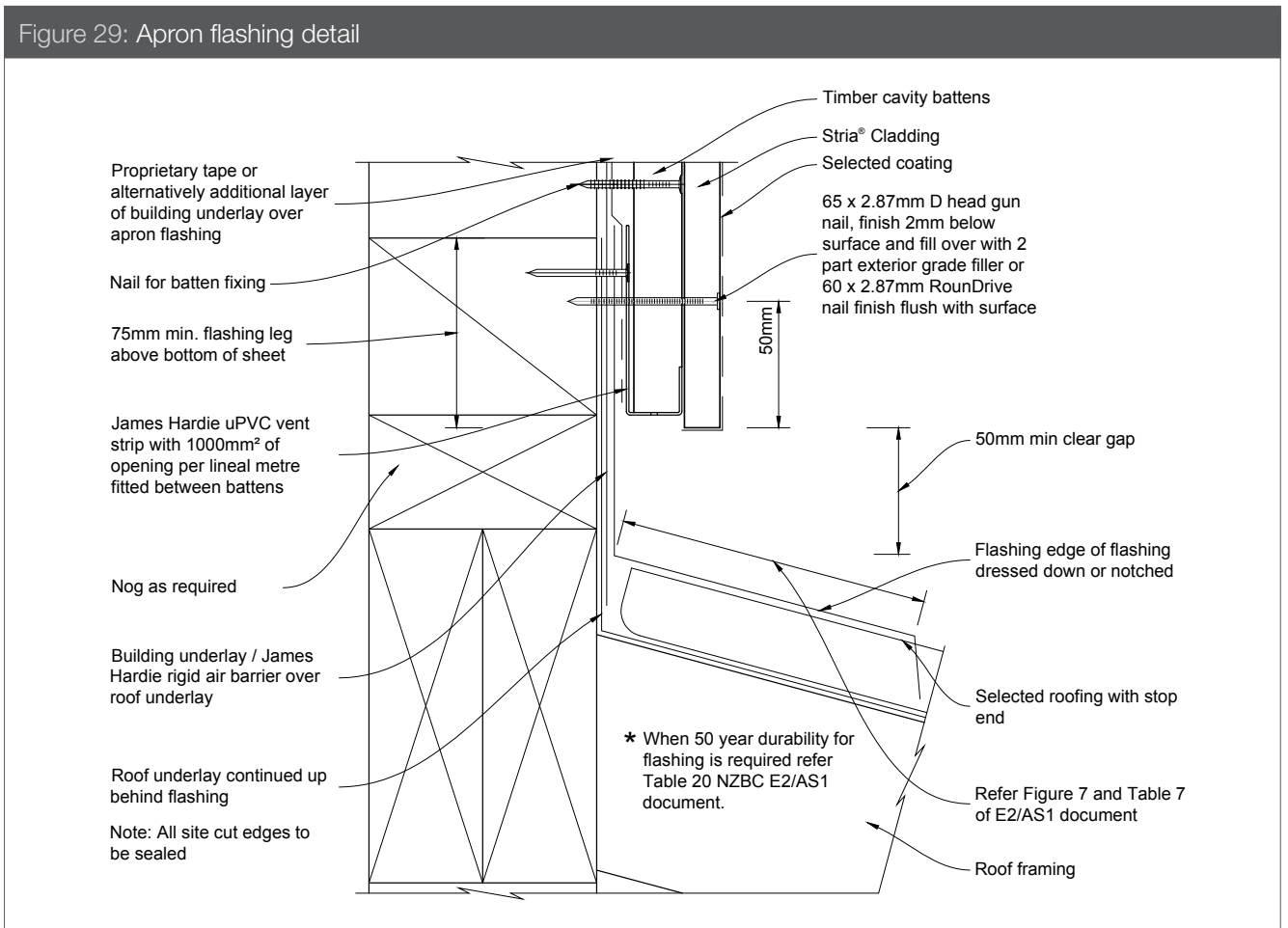

Figure 30: Parapet flashing

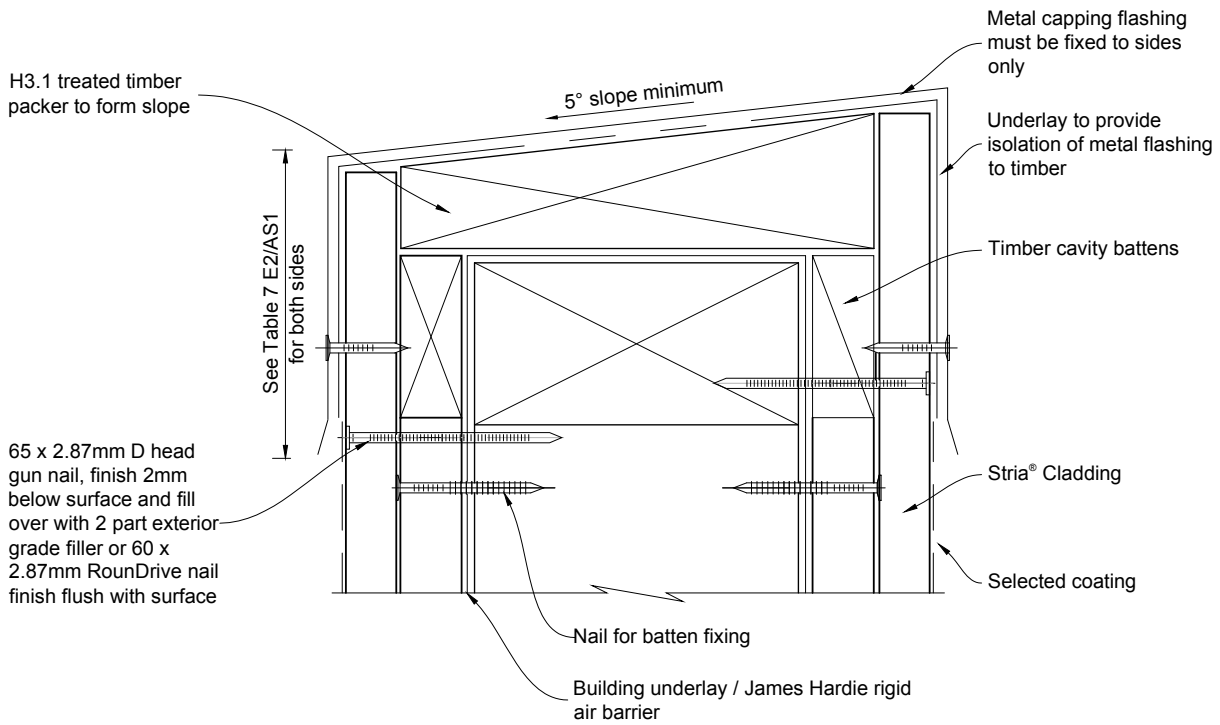

Figure 31: Roof to wall junction detail

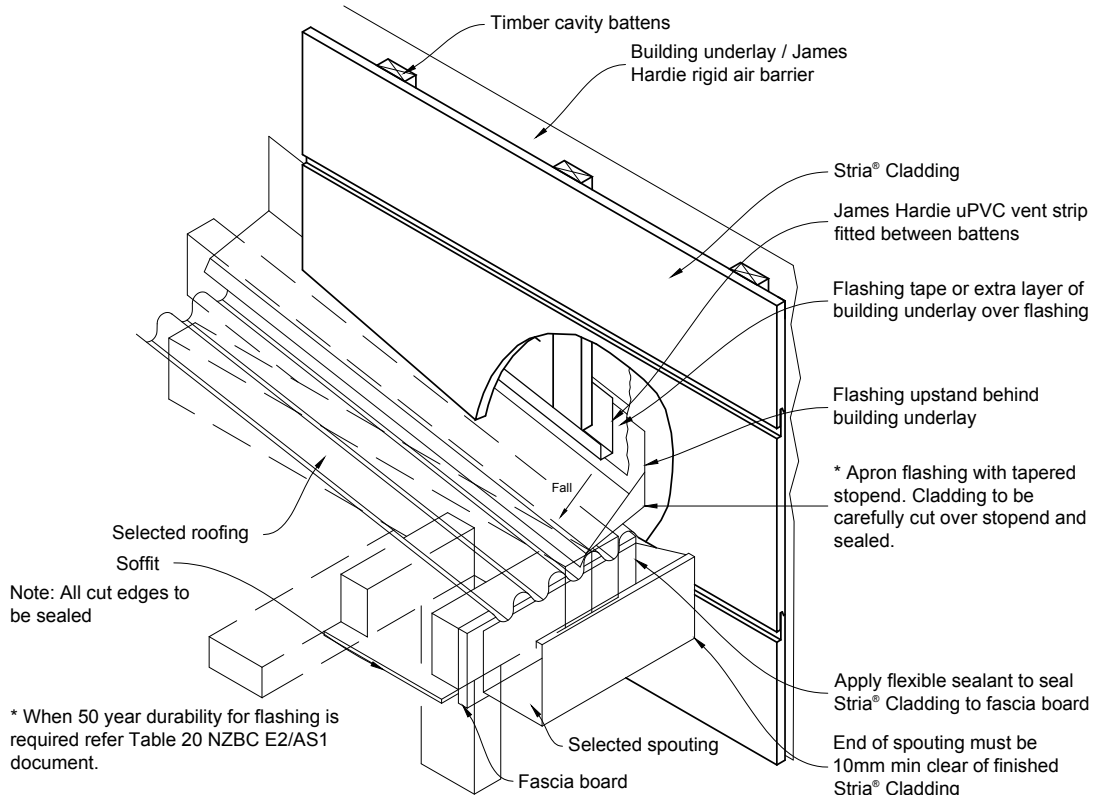

Figure 32: Meter box at sill

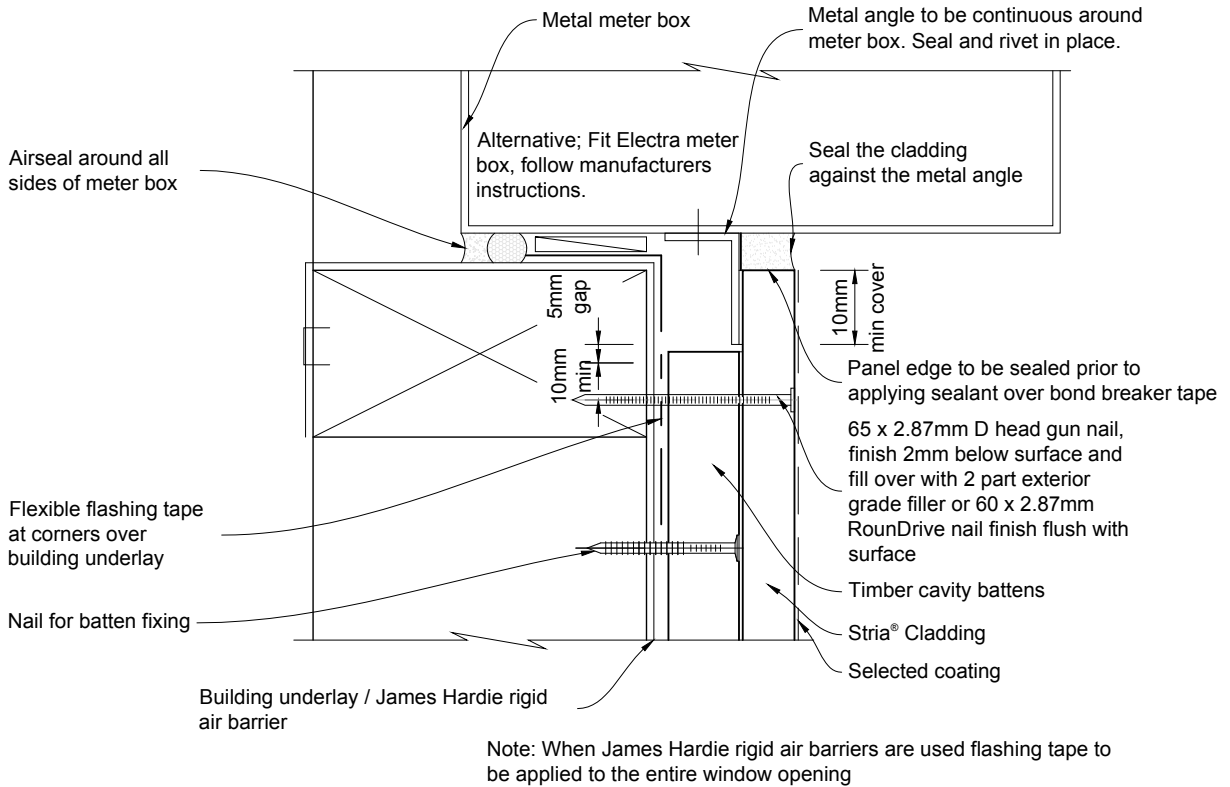
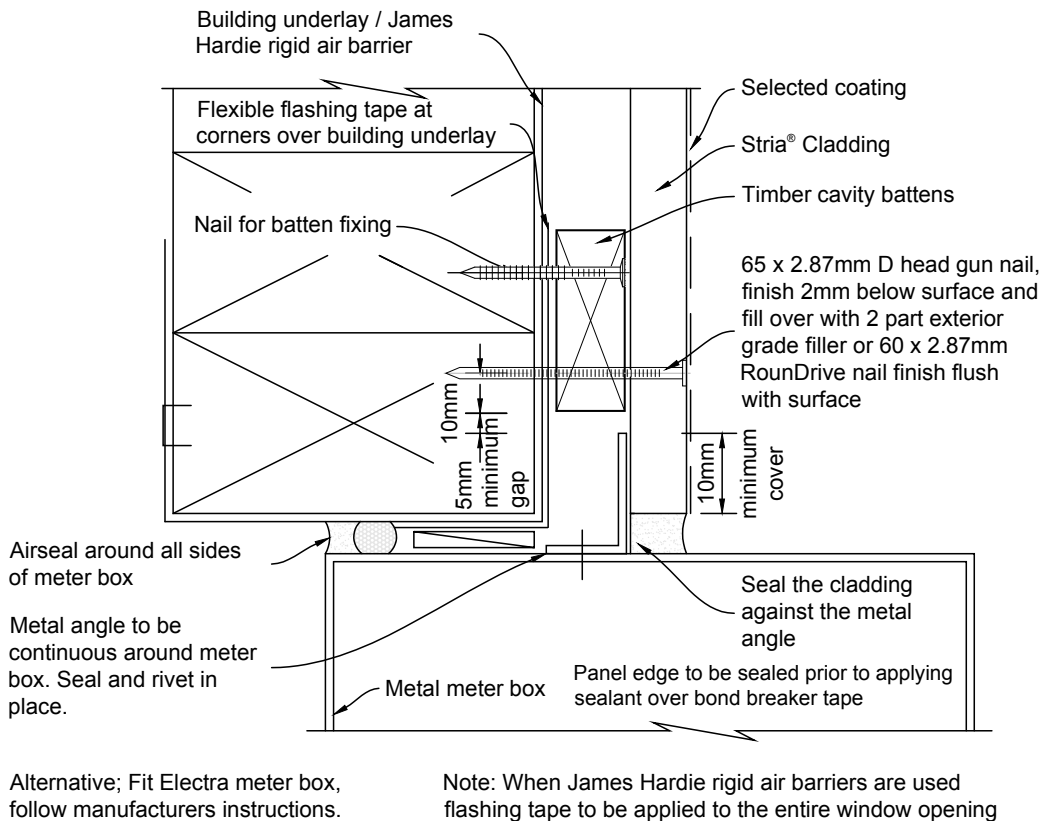

Figure 33: Meter box at jamb









# Product Warranty

**Stria**<sup>®</sup>  
CLADDING

## February 2015

James Hardie New Zealand (“James Hardie”) warrants for a period of 15 years from the date of purchase that the Stria<sup>®</sup> Cladding (the “Product”), will be free from defects due to defective factory workmanship or materials and, subject to compliance with the conditions below, will be resistant to cracking, rotting, fire and damage from termite attacks to the extent set out in James Hardie’s relevant published literature current at the time of installation. James Hardie warrants for a period of 15 years from the date of purchase that the accessories supplied by James Hardie will be free from defects due to defective factory workmanship or materials.

Nothing in this document shall exclude or modify any legal rights a customer may have under the Consumer Guarantees Act or otherwise which cannot be excluded or modified at law.

## CONDITIONS OF WARRANTY:

The warranty is strictly subject to the following conditions:

- a) James Hardie will not be liable for breach of warranty unless the claimant provides proof of purchase and makes a written claim either within 30 days after the defect would have become reasonably apparent or, if the defect was reasonably apparent prior to installation, then the claim must be made prior to installation;
- b) this warranty is not transferable;
- c) the Product must be installed and maintained strictly in accordance with the relevant James Hardie literature current at the time of installation and must be installed in conjunction with the components or products specified in the literature. Further, all other products, including coating and jointing systems, applied to or used in conjunction with the Product must be applied or installed and maintained strictly in accordance with the relevant manufacturer’s instructions and good trade practice;
- d) the project must be designed and constructed in strict compliance with all relevant provisions of the current New Zealand Building Code (“NZBC”), regulations and standards;
- e) the claimant’s sole remedy for breach of warranty is (at James Hardie’s option) that James Hardie will either supply replacement product, rectify the affected product or pay for the cost of the replacement or rectification of the affected product;
- f) James Hardie will not be liable for any losses or damages (whether direct or indirect) including property damage or personal injury, consequential loss, economic loss or loss of profits, arising in contract or negligence or howsoever arising. Without limiting the foregoing James Hardie will not be liable for any claims, damages or defects arising from or in any way attributable to poor workmanship, poor design or detailing, settlement or structural movement and/or movement of materials to which the Product is attached, incorrect design of the structure, acts of God including but not limited to earthquakes, cyclones, floods or other severe weather conditions or unusual climatic conditions, efflorescence or performance of paint/coatings applied to the Product, normal wear and tear, growth of mould, mildew, fungi, bacteria, or any organism on any Product surface or Product (whether on the exposed or unexposed surfaces);
- g) all warranties, conditions, liabilities and obligations other than those specified in this warranty are excluded to the fullest extent allowed by law;
- h) if meeting a claim under this warranty involves re-coating of Products, there may be slight colour differences between the original and replacement Products due to the effects of weathering and variations in materials over time.

Disclaimer: The recommendations in James Hardie’s literature are based on good building practice, but are not an exhaustive statement of all relevant information and are subject to conditions (c), (d), (f) and (g) above. James Hardie has tested the performance of the Stria<sup>®</sup> Cladding when installed in accordance with the Stria<sup>®</sup> Cladding Timber Cavity Batten technical specification, in accordance with the standards and verification methods required by the NZBC and those test results demonstrate the product complies with the performance criteria established by the NZBC. However, as the successful performance of the relevant system depends on numerous factors outside the control of James Hardie (e.g. quality of workmanship and design) James Hardie shall not be liable for the recommendations made in its literature and the performance of the relevant system, including its suitability for any purpose or ability to satisfy the relevant provisions of the NZBC, regulations and standards, as it is the responsibility of the building designer to ensure that the details and recommendations provided in the relevant James Hardie installation manual are suitable for the intended project and that specific design is conducted where appropriate.

Copyright February 2015. © James Hardie New Zealand. TM and <sup>®</sup> denotes a Trademark or Registered Mark owned by James Hardie Technology Limited.

**Ask James Hardie**<sup>™</sup>  
Call 0800 808 868  
[www.jameshardie.co.nz](http://www.jameshardie.co.nz)





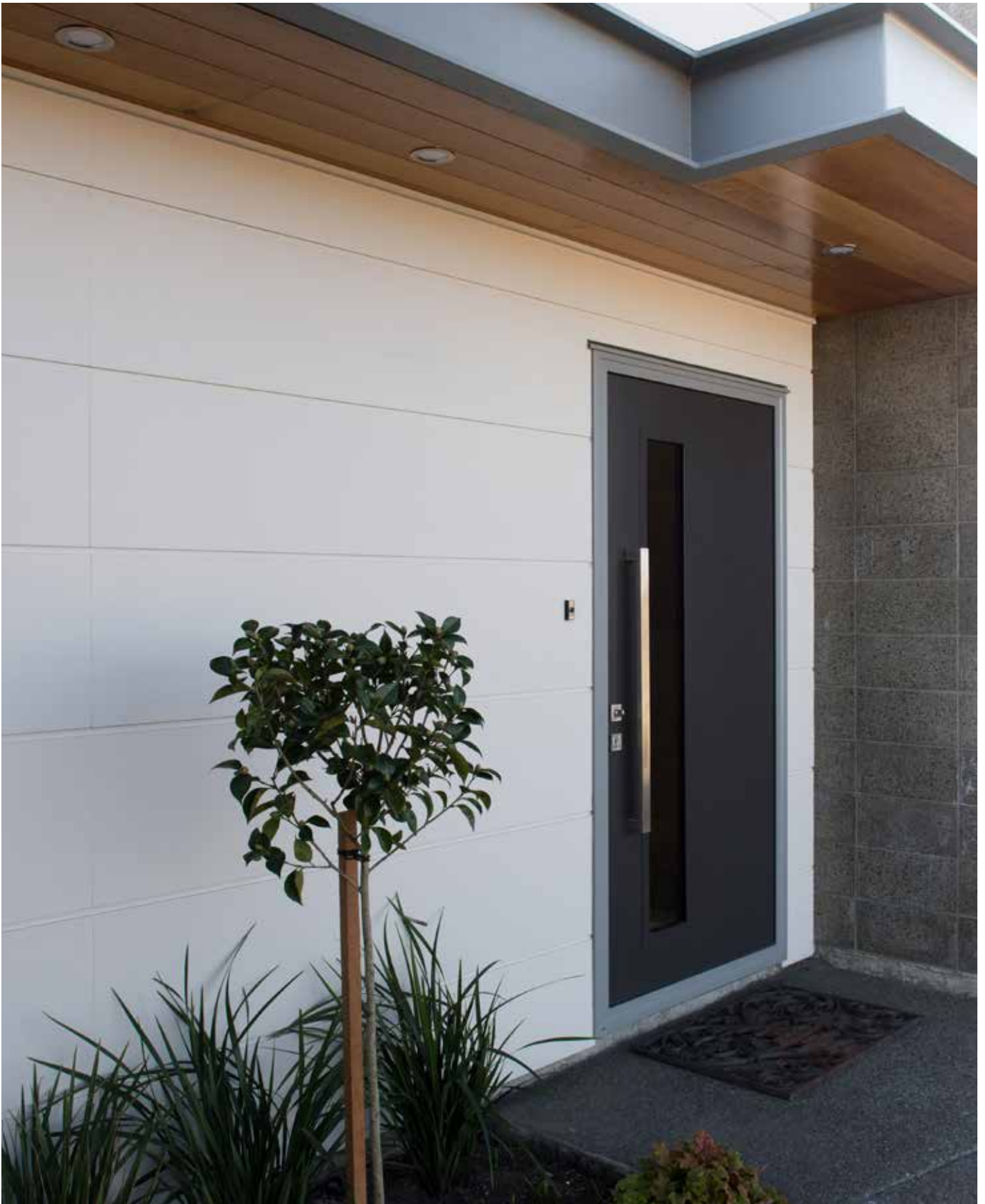

Ask James Hardie™ | Call 0800 808 868 | [jameshardie.co.nz](http://jameshardie.co.nz)