



Technical Specification

Contents

1	APPLICATION AND SCOPE	3	4	PREPARATION	6
1.1	Application	3	4.1	Building Underlay or HomeRAB Pre-Cladding	6
1.2	Scope	3	4.2	Rigid Air Barrier	6
1.3	Details	3	4.3	Flashing	6
1.4	Specific Design	3	4.4	Vent Strip	6
2	DESIGN	3	4.5	Cavity Battens	6
2.1	Compliance	3	4.6	Intermediate Support	6
2.2	Responsibility	3	4.7	Corners	6
2.3	Site and Foundation	3	4.8	Junctions and Penetrations	6
2.4	Ground Clearances	4	5	FIXING LINEA® WEATHERBOARD	7
2.5	Moisture Management	4	5.1	General	7
2.6	Structure	4	5.2	Fastener Durability	7
2.7	Wind Loading	4	5.3	Nail Sizes and Fixing Method	7
2.8	Structural Bracing	4	5.4	Gun Nailing	8
2.9	Fire Rated Walls	4	6	JOINTING	8
2.10	Energy Efficiency	4	7	FINISHING	8
3	FRAMING	5	7.1	Preparation and Priming	8
3.1	General	5	7.2	Sealants	8
3.2	Timber Grade	5	7.3	Painting	8
3.3	Durability	5	8	STORAGE AND HANDLING	8
3.4	Frame Construction	5	9	MAINTENANCE	8
3.5	Tolerances	5	10	PRODUCT INFORMATION	9
			10.1	Manufacturing and Classification	9
			10.2	Trim	9
			10.3	Durability	9
			10.4	Product Sizes and Mass	9
			10.5	Size and Weight	9
			11	SAFE WORKING PRACTICES	10
			12	PRODUCT SIZES	11
			13	ACCESSORIES	12
			14	DETAILS	14
				PRODUCT WARRANTY	47

WE VALUE YOUR FEEDBACK

To continue with the development of our products and systems, we value your input. Please send any suggestions, including your name, contact details, and relevant sketches to:

Ask James Hardie™
Fax 0800 808 988
literaturefeedback@jameshardie.co.nz



1 Application and scope

1.1 APPLICATION

Linea® Weathrboard is a 16mm thick, pre-primed bevel back fibre cement weatherboard and is classified as lightweight wall cladding suitable for residential and light commercial construction using timber framed external walls. Linea Weatherboard is available in 135mm, 150mm and 180mm widths.

James Hardie also has available:

- Axent™ Fascia in two widths. Axent Fascia is a 16mm thick, pre-primed fibre cement product designed to accommodate James Hardie soffit linings.
- Axent™ Trim comes in a variety of widths for use as decorative trims around openings and external corners. Axent Trim is a 16mm thick, pre-primed fibre cement product.

If you are a specifier

Or other responsible party for a project ensure that the information in this document is appropriate for the application you are planning and that you undertake specific design and detailing for areas which fall outside the scope of these specifications.

If you are an installer

Ensure that you follow the design, moisture management principles, associated figures and material selection provided by the designer and this James Hardie Technical Specification.

All the details provided in this document must be read in conjunction with the specifiers specification.

Make sure your information is up to date

When specifying or installing James Hardie products, ensure you have the current manual. If you're not sure you do, or, if you need more information, visit www.jameshardie.co.nz or Ask James Hardie on 0800 808 868.

1.2 SCOPE

This specification covers the use of Linea Weatherboard on buildings that fall within the scope limitations of the New Zealand Building Code (NZBC) Acceptable Solution E2/AS1, Paragraph 1.1.

This specification includes the use of Linea Weatherboard in both direct to stud and cavity construction method and must be read in conjunction with the current BRANZ Appraisals for Linea Weatherboard.

This specification also covers the use of Linea Weatherboard in cavity construction for specific design projects (SED) subject to a wind pressure of 2.5kPa (ULS) maximum. This document is intended for use by architects, designers, specifiers or builders who are involved in specifying Linea Weatherboard. The document also serves the purpose of an installation manual for this product.

1.3 DETAILS

Various Linea Weatherboard details are provided in the Details section of this document. This specification and details in CAD file are also available to download from our website at www.jameshardie.co.nz.

1.4 SPECIFIC DESIGN

For use of Linea Weatherboard outside this published scope, the architect, designer or engineer must undertake specific design.

For advice on designs outside the scope of this specification, Ask James Hardie on 0800 808 868.

2 Design



2.1 COMPLIANCE

Linea Weatherboard direct fixed and cavity cladding has been issued a CodeMark certificate number GM-10-30018 which confirms Linea Weatherboard is deemed to comply with the requirements of NZBC. Please refer to our website www.jameshardie.co.nz for a copy of the CodeMark certificate. Linea Weatherboard also has a BRANZ Appraisal number 446 (2010) and 447 (2010) at www.branz.co.nz or www.jameshardie.co.nz.

2.2 RESPONSIBILITY

The specifier or other party responsible for the project must ensure that the information and details in this specification are appropriate for the intended application and that additional detailing is performed for specific design or any areas that fall outside the scope of this technical specification. For applications outside the scope of this literature and figures which are not provided herein, the architect, designer or engineer must undertake specific design and it should be ensured that the intent of their design meets the requirements of the NZBC.

All dimensions shown are in millimetres unless noted otherwise. All New Zealand Standards referenced in this manual are current edition and must be complied with.

James Hardie conducts stringent quality checks to ensure that any product manufactured falls within our quality spectrum. It is the responsibility of the builder to ensure that the product meets aesthetic requirements before installation. James Hardie will not be responsible for rectifying obvious aesthetic surface variations following installation.

2.3 SITE AND FOUNDATION

The site on which the building is situated must comply with the NZBC Acceptable Solution E1/AS1 'Surface Water'. Foundation design must comply with the requirements of NZS 3604 'Timber Framed Buildings' or be as per specific engineering design. The grade of adjacent finished ground must slope away from the building to avoid any possibility of water accumulation in accordance with the NZBC requirements.

2.4 GROUND CLEARANCES

The clearance between the bottom edge of cladding and paved/unpaved ground must comply with section 9.1.3 of E2/AS1. The finished floor level must also comply with these requirements. These clearances must be maintained throughout the life of the building.

Linea Weatherboards must overhang the bottom plate on a concrete slab by a minimum of 50mm as required by the NZBC Acceptable Solution, E2/AS1 Table 18.

On the roofs and decks the minimum clearance must be 50mm.

Do not install external cladding such that it may remain in contact with water or ground.

2.5 MOISTURE MANAGEMENT

It is the responsibility of the specifier to identify moisture related risks associated with any particular building design.

Wall construction design must effectively manage moisture, considering both the interior and exterior environments of the building, particularly in buildings that have a higher risk of wind driven rain penetration or that are artificially heated or cooled. Walls shall include those provisions as required by the NZBC Acceptable Solution E2/AS1 'External Moisture'. In addition, all wall openings, penetrations, junctions, connections, window sills, heads and jambs must incorporate appropriate flashings for waterproofing. The other materials, components and installation methods used to manage moisture in the walls, must comply with the requirements of relevant standards and the NZBC. For information in relation to designing for weathertightness, refer to BRANZ and the Ministry of Business Innovation & Employment (MBIE) updates on the following websites, respectively www.branz.co.nz and www.dbh.govt.nz.

2.6 STRUCTURE

Timber framing must comply with NZS 3604 for buildings or parts of buildings within the scope limitations of NZS 3604. Buildings or parts of buildings outside the scope of NZS 3604 must be to a specific engineering design in accordance with NZS 3603 and AS/NZS 1170. Where specific engineering design is required, the framing stiffness must be equivalent to or more than the framing provisions of NZS 3604. In all cases stud spacing must not exceed 600mm centres maximum for buildings designed to NZS 3604 and 400mm centres maximum for specific engineering design buildings subject to design wind pressures higher than 1.5kPa.

For timber frame walls longer than 12m, it is best practice to allow for construction joints to accommodate movements generated due to timber shrinkage or deflection etc

2.7 WIND LOADING

Linea Weatherboard cladding is suitable for use in all wind zones as defined in NZS 3604 and is also suitable for use in SED wind pressures up to 2.5kPa (ULS).

For wind pressures higher than those mentioned above, contact James Hardie at 0800 808 868 for assistance.

2.8 STRUCTURAL BRACING

Linea Weatherboard direct fixed installed as per Linea Weatherboard specific bracing details will provide bracing for buildings designed and constructed in accordance with NZS 3604. The Linea Weatherboard bracing systems have been independently tested by SCION using direct fixed construction. The following range of bracings can be achieved

- Wind 75 – 130 BU'S/m
- Earthquake 67 – 101 BU'S/m

Refer to the James Hardie Bracing Design Manual for details.

2.9 FIRE RATED WALLS

Walls clad with Linea Weatherboard using a direct fix or cavity construction method can achieve fire ratings of up to 90/90/90 when constructed in accordance with the James Hardie 'Fire and Acoustic' Design Manual. Linea Weatherboard must be face fixed for Fire Rated applications.

Refer to Fire and Acoustic Design Manual for further information about fire rated systems.

2.10 ENERGY EFFICIENCY

External walls constructed using Linea Weatherboard as per this technical specification, using bulk insulation, where the area of glazing is 30% or less of the total wall area, complies with the minimum R-value requirements for walls as per the NZBC Acceptable Solution H1/AS1 (NZBC Clause H1 Energy Efficiency), Replacement Table 1. To meet the minimum thermal insulation requirements for the construction, the bulk insulation as specified in Table 1 must be used. This insulation may be substituted with insulation material having higher R-values. The thermal insulation of a wall is affected when the depth of the timber framing is increased or decreased or stud spacing is decreased. The calculation used in Table 1 is based on a timber framing size 90 x 45mm and an internal lining material such as James Hardie Villaboard® Lining or a 10mm plasterboard.

Table 1

Insulation capability		
Climate Zone	Construction R-Value Requirement	Minimum R-Value of Insulation Required
1 and 2	1.9 m ² °C/W	#R2.0
3	2.0 m ² °C/W	#R2.2

Total construction R-Value depends on the insulation material used and the framing ratio. The insulation material R-Values specified in this table are for studs spaced at 600mm c/c and nogs spaced at 800mm c/c.

To achieve higher construction R-Values the wall insulation material must be replaced with an insulation material having higher R-Values to suit the requirements.

For further guidance on insulation requirement refer to current edition of 'House Insulation Guide' published by BRANZ.

3 Framing

3.1 GENERAL

This Linea Weatherboard technical specification is only suitable for timber-framed buildings. Other framing materials are outside the scope of this specification.

For Steel Framing refer to James Hardie Claddings Installation to Steel Framing Technical Supplement.

3.2 TIMBER GRADE

Timber must be graded in accordance with NZS 3631 'New Zealand Timber Grading Rules'. The timber grade to be used must be in accordance with NZS 3604 requirements.

3.3 DURABILITY

To comply with the NZBC requirements the external framing must be treated to a minimum H1.2 treatment. Refer to the NZBC Acceptable Solution B2/AS1 Durability for further information about the durability requirements. For timber treatment information refer to NZS 3602 (Timber and Wood-Based Products for use in Buildings) and NZS 3640 (Chemical Preservation of Round and Sawn Timber) for minimum timber treatment selection and treatment requirements. Also refer to framing manufacturer's literature for further guidance on timber selection.

Framing must be protected from moisture at sites in accordance with the recommendations of framing manufacturers.

Note: refer to NZS 3602 for information about the allowable moisture content in timber.

3.4 FRAME CONSTRUCTION

For buildings within the scope of NZS 3604 the framing sizes and set-out must comply with NZS 3604 with stud, nog/dwang centres as required by this specification.

In case of gable end trusses sitting on top plates of external wall frame, the frame size must comply with the minimum timber sizes stipulated for wall frames in section 8 of the NZS 3604.

3.4.1 Direct fixed construction method

The following framing must be provided for direct fixed construction method:

- Studs must be provided at 600mm centres maximum.
- Nogs must be provided at 1200mm centres maximum.
- Double studs are required at internal corners.
- Extra packers may be required at external corners.
- Extra studs are required for aluminium internal corner sections.

3.4.2 Cavity construction method

The following framing must be provided for cavity construction method:

- When studs are at 600mm centres the nogs must be provided at 800mm centres maximum.
- When studs are at 400mm centres the nogs may be provided at 1200mm centres maximum.
- Double studs are required at internal corners.
- Extra packers may be required at external corners.
- Extra studs are required for aluminium internal corner sections.

3.4.3 Specific Engineering Design (SED)

For EH wind zone and specific engineering design projects the timber framing is required to be designed in accordance with NZS 3603 and AS/NZS 1170. The minimum framing sizes and layout must comply with this specification.

- Stud spacing 400mm centres maximum
- Nog spacing 1200mm centres maximum
- Other requirements as per 3.5.2 above

3.5 TOLERANCES

In order to achieve an acceptable wall finish, it is imperative that framing is straight and true. Framing tolerances must comply with the requirements of NZS 3604. All framing must be made flush.

4 Preparation

4.1 BUILDING UNDERLAY OR HOMERAB PRE-CLADDING

Building underlay must be provided as per the requirements of the NZBC Acceptable Solution E2/AS1 'External Moisture' Table 23. The building underlay must be fixed in accordance with E2/AS1 and the underlay manufacturer's recommendations. Walls which are not lined on the inside face e.g. garage walls or gable ends must include a rigid sheathing or an air barrier behind the cladding which complies with the requirements of the NZBC Acceptable Solution E2/AS1 Table 23. HomeRAB Pre-Cladding is suitable for use in these applications. It must be installed in accordance with James Hardie Rigid Air Barriers installation manual.

4.2 RIGID AIR BARRIER

For EH wind zone or Specific Engineering Design (SED) projects where the design wind pressures are between 1.5kPa (ULS) and 2.5kPa (ULS), RAB Board (6mm) must be used. Refer to James Hardie Rigid Air Barriers installation manual for information regarding its installation.

4.3 FLASHING

All wall openings, penetrations, intersections, connections, window sills, heads and jambs must be flashed prior to weatherboard installation. Please refer to moisture management requirements in Clause 2.5. The building underlay must be appropriately incorporated with penetration and junction flashings. Materials must be lapped in such a way that water tracks down to the exterior on the face of building underlay. James Hardie will assume no responsibility for water infiltration within the wall due to poor installation of flashings or building underlays. The selected flashing materials must comply with the durability requirements of Table 20 of the NZBC Acceptable Solution E2/AS1.

4.4 VENT STRIP

The James Hardie uPVC cavity vent strip must be installed at the bottom of all walls constructed using the drained and ventilated cavity construction method. James Hardie uPVC vent strip has an opening area of 1000mm²/m length. It is important that the openings in the vent strip are kept clear and unobstructed to allow free drainage and ventilation of cavities.

4.5 CAVITY BATTENS

Buildings with a risk score of 13-20 calculated in accordance with the NZBC Acceptable Solution E2/AS1 Table 3 require Linea Weatherboards to be installed on a cavity.

The cavity battens provide airspace between the frame and cladding and are considered a "packer" only in this specification.

The timber battens must be minimum H3.1 treated in accordance with NZS 3640 (Chemical Preservation of Round and Sawn Timber) to comply with the durability requirements of B2/AS1.

Cavity battens must comply with E2/AS1 and:

- be minimum 18mm thick.
- be minimum as wide as the width of studs.
- be fixed by the cladding fixings to the main framing through the building underlay.
- fix cavity battens to studs at maximum 600mm centres.
- until claddings are fixed the battens need only to be tacked to framing with 40 x 2.8mm nails at 800mm centres maximum.

(Batten fixing is required temporarily to keep them straight on the wall during construction.)

4.6 INTERMEDIATE SUPPORT

Where studs are at 600mm centres an intermediate means of restraining the building underlay and insulation from bulging into the cavity shall be installed. An acceptable method to achieve this is using one of the following:

- intermediate cavity batten between the studs.
- 75mm galvanised mesh.
- polypropylene tape at 300mm centres fixed horizontally and drawn taut.

No intermediate supports are required:

- where studs are at maximum 400mm centres; or,
- when rigid sheathings instead of building underlays are used.

4.7 CORNERS

Anticipated joist shrinkage must be allowed for in the design process. Do not run trims or aluminium extrusions continuously across solid floor joists. There are a number of options to select from when detailing external corners:

- 90° corner soaker in aluminium, copper or stainless steel. Refer to Figures 7 and 33.
- 135° corner soaker 180mm aluminium, contact James Hardie
- Box corners using Axent Trim. Refer to Figures 3, 4 and 30.
- Mitred corners to weatherboards. Refer to Figures 5 and 31.
- Aluminium boxed corners. Refer to Figures 6 and 32.

There are a number of options to select from when detailing internal corners:

- Scribed corner. Refer to Figures 8 and 34.
- 90° or 135° Aluminium W-mould. Refer to Figures 9, 10, 35 and 36.

4.8 JUNCTIONS AND PENETRATIONS

Refer to Clause 2.5 of this specification for moisture management requirements. All windows and doors must be detailed as per the requirements of this specification. James Hardie has developed the window details for Linea Weatherboards which meet the requirements of E2 'External Moisture', an approved document of the NZBC. Refer to Figures 11 to 22 and 38 to 51.

5 Fixing Linea Weatherboard

5.1 GENERAL

The horizontal lap of Linea Weatherboards must be 30mm minimum. In certain scenarios you may require to creep up the lap. This must not exceed 33mm. Linea Weatherboards must be kept dry whilst in storage prior to and during fixing. Cut ends which are exposed after installation or where sealant is applied to the boards such as slimline box corners, internal corners, mitred external corners etc, must be primed prior to installation. Dust and loose material must be removed before priming.

A minimum H3.1 treated timber cant strip must be provided to support the bottom board on the wall. Refer to Figure 1 and Figure 26.

5.2 FASTENER DURABILITY

Fasteners must meet the minimum durability requirements of the NZBC. NZS 3604 specifies the requirements for fixing's material to be used in relation to the exposure conditions and are summarised in Table 2.

Table 2

Exposure conditions and nail selection prescribed by NZS 3604

NAIL MATERIAL

Zone D *	Zone C outside sea spray zone and Zone B and Geothermal hot spots	Bracing — All zones
Grade 316 Stainless	Hot-dipped galvanised or 316 stainless	Grade 316 stainless

* (Zone C areas where local knowledge dictates that increased durability is required, appropriate selection shall be made) Microclimate conditions as detailed in NZS 3604, Paragraph 4.2.4 require SED.

Also refer to the NZBC Acceptable Solution 'E2/AS1' Table 20 and 21 for information regarding the selection of suitable fixing materials and their compatibility with other materials.

5.3 NAIL SIZE AND FIXING METHOD

Linea Weatherboards and Axent Trim must be fixed to timber with the types of nails specified in Tables 3 and 4, in accordance with the following requirements:

- Linea Weatherboard can either be face/exposed fixed or concealed fixed.
- Linea Weatherboard must be fixed into studs at maximum 600mm centres. Fixing centres to coincide with stud spacing. Refer to Figure 2 and 28.
- All concealed nails must be driven flush with the board surface.
- When concealed fixing Linea Weatherboards, nails must be driven under the lap of boards, except at all corners and vertical edges of openings where Linea Weatherboards must be face fixed. Refer to Figure 2 and Figure 29.
- Nails must be fixed 25mm from the end of the board when hand nailing. For gun nailing refer to Section 5.4.
- When using concealed fixing method, any gaps that may appear under the lap due to site conditions can be minimised

by fixing a jolt head nail through the lap as per the exposed nailing method. Refer to Figure 2 and 29.

- When using concealed fixing method, Linea Weatherboard can also be tied together by face fixing through the lap using 32mm brad nails if desired.
- When using a rigid air barrier like HomeRAB Pre-Cladding or RAB Board, the cladding fixing nails must be increased in length equal to the thickness of the rigid air barrier.
- When face fixing Linea Weatherboard, the upper board must be pre-drilled before fixing with a jolt head nail.

Table 3

Nail requirements for Linea Weatherboards

DIRECT TO STUD FIXING

Concealed Nailing	
40 x 2.8mm HardieFlex™ nails	Finish flush with the board surface.
Face Nailing	
60 x 3.15mm jolt head nails	Hot-dipped galvanised jolt head nail with pre-drilling* through the top weatherboard.
	Stainless steel jolt head nail with pre-drilling* through the top weatherboard.

CAVITY FIXING

Concealed Nailing	
60 x 3.15mm HardieFlex™ nails	Finish flush with the board surface.
Face Nailing	
75 x 3.15mm jolt head nails	Hot-dipped galvanised jolt head nail with pre-drilling* through the top weatherboard.
	Stainless steel jolt head nail with pre-drilling* through the top weatherboard.

EH Wind Zone and SED Projects (1.5kPa - 2.5kPa Wind Pressure)

Face Nailing	
90 x 4.0mm jolt head nail	Hot-dipped galvanised jolt head nail with pre-drilling** through the top weatherboard.
	Stainless steel shank jolt head nail with pre-drilling** through the top weatherboard.

Table 4

Nail requirements for trim

Single Thickness	60mm jolt head nails. If fixing over Linea Weatherboard use predrilled* 75 x 3.15mm jolt head nails.
Double Thickness	60mm jolt head nails.
Single plus packer	If fixing over Linea Weatherboard use 75 x 3.15mm jolt head nails through a pre-drilled* hole. When fixing to timber support use 60mm jolt head nails.

* Use a 3.0mm drill bit. ** Use a 3.5mm drill bit

Note: Special fixing arrangements are required for bracing and fire-resistance rated wall systems. For more information Ask James Hardie on 0800 808 868.

5.4 GUN NAILING

Linea Weatherboard can also be gun-nailed with a D head or RounDrive nail when concealed fixing method is used.

- Gun-nailing must not be used when Linea Weatherboard is used for bracing.
- Nails must be no closer than 50mm from the ends of boards when gun nailing is used — double studs will be required.
- Be minimum length and gauge as per Table 3.
- Be finished flush with surface of board.

6 Jointing

The ends of Linea Weatherboards are jointed off-stud by means of a tongue and groove joint. Tongue and groove joints may be located centrally between studs but no closer than 100mm from the edge of a stud. The joints must be staggered by 600mm minimum. Sealant must be provided in the tongue and groove joint.

7 Finishing

Note: Protective coating of Linea Weatherboard and Axent Trim is required in order to meet the durability requirements of the NZBC.

7.1 PREPARATION AND PRIMING

The Linea Weatherboard and Axent Trim must be dry before painting. Punch and fill all exposed nails a maximum of 2mm below the surface. Fill the hole with an exterior grade builders fill, allow to cure and sand smooth ready for priming. Prime the filled holes in accordance with paint manufacturer's specifications.

It is not recommended to seal under the lap of weatherboards as it helps circulation of air behind the weatherboard cladding.

7.2 SEALANTS

All sealants must demonstrate the ability to meet the relevant requirements of the NZBC and hold a current BRANZ Appraisal. Application and use of sealants must comply with manufacturer's instructions. Sealants, if coated, must be compatible with the paint system.

7.3 PAINTING

All Linea Weatherboards are pre-primed on their face and bottom edge with a factory applied acrylic base coat.

Linea Weatherboard must be painted within 90 days of installation. There is no restriction on the LRV of paint to be applied on the Linea Weatherboard. All exposed faces, including the top edges under the sills and bottom edges of Linea Weatherboard, Axent Trim and accessories must be finished with latex exterior paint system complying with any of parts 7, 8, 9, and 10 of AS 3730.

Dark coloured paints can be used on Linea Weatherboard and Trim. The dark colours in certain environments may fade over a period of time. Special paints/coatings are required in certain harsh environments.

Stainless steel soakers are generally left natural. For painting over stainless steel soakers, refer to paint manufacturer as special preparation and paints are required.

8 Storage and handling

Paint selection and the preparation required is dependant on paint chosen. Refer to the paint manufacturer for information before starting painting.

Linea Weatherboards and Axent Trim must be laid flat on a smooth level surface. To ensure optimum performance, store weatherboards under cover and keep dry prior to fixing. If the weatherboards should become wet, allow to dry thoroughly before fixing. Do not carry weatherboards on the flat, carry in the vertical position to avoid excessive bending.

9 Maintenance

The extent and nature of maintenance will depend on the geographical location and exposure of the building. It is the responsibility of the specifier to determine normal maintenance requirements to comply with NZBC Acceptable Solution B2/AS1. As a guide, it is recommended that basic normal maintenance tasks shall include but not be limited to:

- Washing down exterior surfaces every 6-12 months*,
- Re-applying exterior protective finishes**,
- Maintaining the exterior envelope and connections including joints, penetrations, flashings and sealants,
- Cleaning out gutters, blocked pipes and overflows as required,
- Pruning back vegetation close to or touching the building,
- The clearances between the bottom edge of Linea Weatherboard and the finished/unfinished ground must always be maintained.
- Stainless steel soakers used in extreme coastal conditions or in sea spray zones may show some signs of 'tea staining'. It is an aesthetic issue and to minimise staining soaker must be washed/polished frequently.

*Do not use a water blaster to wash down the cladding.

**In extreme coastal conditions or sea spray zones, wash every 3-4 months.

**Refer to your paint manufacturer for washing down and recoating requirements related to paint performance.

10 Product information

10.1 MANUFACTURING AND CLASSIFICATION

James Hardie New Zealand is an ISO 9001 Telarc certified manufacturer. Linea Weatherboard and Axent Trim are manufactured to meet the requirements of AS/NZS 2908.2: 2000 'Cellulose-Cement Products', Linea Weatherboard has a classification of Type A Category 3 in accordance with this Standard. Linea Weatherboard is an advanced lightweight cement composite building product incorporating James Hardie proprietary Scyon technology.

Linea Weatherboard has a bevel back and tongue and groove at the ends for jointing. The bottom front edge of Linea Weatherboard is chamfered. The weatherboards are supplied pre-primed on their face and bottom edge with an acrylic primer.

Linea Weatherboards and Axent Trim are identified by the printing at regular intervals of the name Linea on the back face.

10.2 JAMES HARDIE TRIM

The Axent Trim, used for box corners, around windows and doors as well as special architectural features, is also made with the CLD technology and is supplied pre-primed with an acrylic primer.

10.3 DURABILITY

Linea Weatherboard and Axent Trim, when installed and maintained as per the technical specification, will meet the durability requirements for claddings as required in the NZBC Approved Document B2 'Durability'.

10.3.1 Resistance to moisture/rotting

Linea Weatherboard and Axent Trim have demonstrated resistance to permanent moisture-induced deterioration (rotting) and has passed the following tests in accordance with AS/NZS 2908.2:

- Water Permeability (Clause 8.2.2)
- Warm Water (Clause 8.2.4)
- Heat Rain (Clause 6.5)
- Soak Dry (Clause 8.2.5).

10.3.2 Control of External Fire Spread

Linea Weatherboard is tested as per Appendix C C7.1.1 and is classified as 'Non-Combustible Material' which is suitable for use as external wall cladding and complies with requirements of paragraph 5.8.1 of Clause C2 to C6 of the NZBC.

10.3.3 Alpine regions

In regions subject to freeze/thaw conditions, Linea Weatherboard must not be in direct contact with snow or ice build up for extended periods, e.g. external walls in alpine regions subject to snow drifts over winter.

The Linea Weatherboard has been tested in accordance with AS/NZS 2908.2 Clause 8.2.3.

10.4 PRODUCT SIZES AND MASS

Available sizes of Linea Weatherboard and Axent Trim and its weight are given in Table 6.

10.5 SIZE AND WEIGHT

Linea Weatherboard is categorised as a Light Weight Wall Cladding as described in NZS 3604. Physical properties of Linea Weatherboard and Axent Trim are provided in Table 6.

11 Safe working practices

WARNING – DO NOT BREATHE DUST AND CUT ONLY IN WELL VENTILATED AREA

James Hardie products contain respirable crystalline silica which is considered by some international authorities to be a cause of cancer from some occupational sources. Breathing excessive amounts of respirable silica dust can also cause a disabling and potentially fatal lung disease called silicosis, and has been linked with other diseases. Some studies suggest smoking may increase these risks. During installation or handling: (1) work in outdoor areas with ample ventilation; (2) minimise dust when cutting by using either 'Score and Snap' knife, fibre cement shears or, where not feasible, use a HardieBlade™ Saw Blade and dust-reducing circular saw attached to a HEPA vacuum; (3) warn others in the immediate area to avoid breathing dust; (4) wear a properly-fitted, approved dust mask or respirator (e.g. P1 or P2) in accordance with applicable government regulations and manufacturer instructions to further limit respirable silica exposures. During clean-up, use HEPA vacuums or wet cleanup methods — never dry sweep. For further information, refer to our installation instructions and Safety Data Sheets available at www.jameshardie.co.nz.

FAILURE TO ADHERE TO OUR WARNINGS, SAFETY DATA SHEETS, AND INSTALLATION INSTRUCTIONS MAY LEAD TO SERIOUS PERSONAL INJURY OR DEATH.

James Hardie recommended safe working practices

CUTTING OUTDOORS

1. Position cutting station so wind will blow dust away from the user or others in working area.
2. Use one of the following methods based on the required cutting rate:

BEST

- Dust reducing circular saw equipped with HardieBlade™ Saw Blade and HEPA vacuum extraction.

GOOD

- Dust reducing circular saw with HardieBlade™ Saw Blade.

SANDING/REBATING/DRILLING/OTHER MACHINING

When sanding, rebating, drilling or machining you should always wear a P1 or P2 dust mask and warn others in the immediate area.

IMPORTANT NOTES

1. For maximum protection (lowest respirable dust production), James Hardie recommends always using "Best" — level cutting methods where feasible.
2. NEVER use a power saw indoors.
3. NEVER use a circular saw blade that does not carry the HardieBlade™ logo.
4. NEVER dry sweep — Use wet suppression or HEPA vacuum.
5. NEVER use grinders.
6. ALWAYS follow tool manufacturers' safety recommendations.

P1 or P2 respirators should be used in conjunction with above cutting practices to further reduce dust exposures. Additional exposure information is available at www.jameshardie.co.nz to help you determine the most appropriate cutting method for your job requirements. If concern still exists about exposure levels or you do not comply with the above practices, you should always consult a qualified industrial hygienist or contact James Hardie for further information.

Working instructions

Refer to recommended Safe Working Practices before starting any cutting or machining of product.

HardieBlade™ Saw Blade

The HardieBlade™ Saw Blade used with a dust-reducing saw connected to a HEPA vacuum is ideal for fast, clean cutting of James Hardie fibre cement products. A dust-reducing saw uses a dust deflector or a dust collector connected to a vacuum system. When sawing, clamp a straight-edge to the sheet as a guide and run the saw base plate along the straight edge when making the cut.



Hole-forming

For smooth clean cut circular holes:

Mark the centre of the hole on the sheet.

Pre-drill a pilot hole.

Using the pilot hole as a guide, cut the hole to the appropriate diameter with a hole saw fitted to a heavy duty electric drill.

For irregular holes:

Small rectangular or circular holes can be cut by drilling a series of small holes around the perimeter of the hole then tapping out the waste piece from the sheet face.



Tap carefully to avoid damage to sheets, ensuring that the sheet edges are properly supported.

Storage and handling

All James Hardie building products should be stored to avoid damage, with edges and corners of the sheets protected from chipping.

James Hardie building products must be installed in a dry state and be protected from rain during transport and storage. The product must be laid flat under cover on a smooth level surface clear of the ground to avoid exposure to water or moisture, etc.

Quality

James Hardie conducts stringent quality checks to ensure that any product manufactured falls within our quality spectrum. It is the responsibility of the builder to ensure that the product meets aesthetic requirements before installation. James Hardie will not be responsible for rectifying obvious aesthetic surface variations following installation.

12 Product sizes

Table 6

Linea Weatherboard and Axent Trim sizes						Coverage Information			
Product	Length (mm)	Width (mm)	Thickness (mm)	End Details	Effective Cover (mm)	No. of planks/ metre height (approx.)	Mass kg/lineal m (approx. at EMC)	Mass kg/m ² (approx. at EMC)	Weight/ packs (60 units/ pack)
Linea Weatherboard 135	4200*	135	16	T & G	105	9.5	2.62	25.70	660.00
Linea Weatherboard 150	4200*	150	16	T & G	120	8.3	3.1	24.93	781.00
Linea Weatherboard 180	4200*	180	16	T & G	150	6.7	3.57	23.92	899.00
Axent Trim 84mm	2600	84	16	Square	N/A	N/A	1.6	N/A	N/A
Axent Trim 100mm	2600	100	16	Square	N/A	N/A	1.9	N/A	N/A

*Length is 4200mm plus 5mm for the tongue and groove making overall length 4205mm

*The effective thickness of finished Linea Weatherboard on the wall at the lap is approximately 33 to 35mm

13 Accessories

Table 7











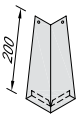
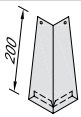
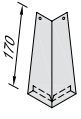
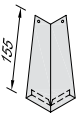

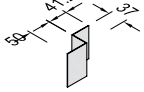
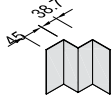
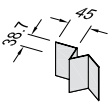

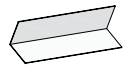
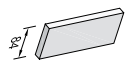
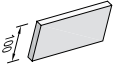
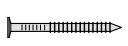



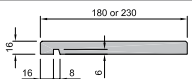

Accessories/Tools supplied by James Hardie			
Accessories	Material number	Size (mm)	Code
	External corner soaker 90° for Linea Weatherboards 180mm <ul style="list-style-type: none"> Aluminium Copper Stainless Steel 	200 long	301186 301188 301197
	External corner soaker 135° for Linea Weatherboards 180mm <ul style="list-style-type: none"> Aluminium 	200 long	301178
	External corner soaker 90° for Linea Weatherboards 150mm <ul style="list-style-type: none"> Aluminium Stainless Steel 	170 long	302820 302821
	External corner soaker 90° for Linea Weatherboards 135mm <ul style="list-style-type: none"> Aluminium Stainless Steel 	155 long	301185 301196
	External Slimline Box Corner Mould	2700 long 4000 long	301195 305809
	Box Corner 'Z' Flashing	2700 long	301203
	Internal 'W' Mould 90°	2700 long 4000 long	301184 305807
	Internal 'W' Mould 135°	2700 long	301183
	Vent Strip	3000 long	302490
	JH Corner Under Flashing 50 x 50mm	3000 long	303745
	Axent Trim 84mm	84 x 2600 long	401943
	Axent Trim 100mm	100 x 2600 long	401930
	HardieFlex™ nail - 5kg	60 x 3.15mm	302782
	HardieFlex™ nail - 5kg	60 x 3.15mm	302784
	HardieBlade™ Saw Blade	4 tooth - 184mm	300660
	HardieBlade™ Saw Blade	6 tooth - 254mm	303375
	Axent Fascia - 180mm - 230mm	4200 long	401843 402230

Table 8

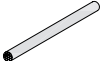
Accessories not supplied by James Hardie

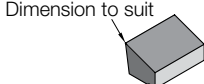
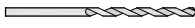
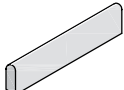
James Hardie recommends the following products for use in conjunction with its Linea Weatherboard and Axent Trim. James Hardie does not supply these products. There may also be some other accessories required depending upon the application. Please contact component manufacturer for information on their warranties and further information on their products.

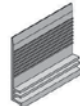
Accessories	Description	Size (MM)	Material/appearance
	Head flashing Required over window heads to be supplied by window installer. Material must comply with Table 20 and 21 of E2/AS1.	To suit	Etch Primed Aluminium/Powder Coated
	D head or RounDrive Nail Gun nail for concealed fixing Linea Weatherboard	50 x 2.87 60 x 3.15	Hot Dip Galvanised Stainless Steel
	HardieFlex™ Hot Dip Galv. Nails For fixing cavity battens.	40 x 2.8mm	Hot Dip Galvanised
	Jolt Head Nail for face fixing to Linea Weatherboard Hot Dip Galvanised or 316 Stainless Steel	50 x 2.8mm 60 x 3.15mm 75 x 3.15mm 90 x 4.0mm	Self colour
	Joint sealant Paintable flexible sealants are recommended for filling the joints. Refer to Section 7.2 for information.	Tube	Sika, Holdfast
	PEF Rod	Polyethylene foam	Sika or similar
	Flexible tape A flexible self-adhesive tape used in preparation of a window. Refer to the Window installation section in this manual for more information. e.g. Tyvek®, Marshall Innovations or similar.	Proprietary tape to adhere to building underlay	Tyvek, Marshall Innovations or similar
	Flashing Material as per Table 20, 'E2/AS1'		Flashing Fabricator
	Planted Sill		H3.1 minimum Treated Timber Timber Merchant or cut on site
	Titanium Coated High Speed Drill Bit. For pre-drilling prior to face fixing with jolt head	3.0mm 3.5mm	
	Timber Scriber To scribe beside window site cut to suit	As required	H3.1 minimum Treated Timber Timber Merchant or cut on site
	Fibre Cement Cutting Blade Diamond tip 305mm diameter circular saw blade to fit drop saw	305mm	Diamond Tipped
	Meter Box Refer Electrical Suppliers		
	Cant Strip Redway Developments 03 358 5775 Predrill the weatherboards when fixing using Redway Development Cant/Vent Strips	To suit	uPVC
	Inseal 3109 Sealing Strip	5 x 3mm x 25mm	Black Compressible Foam
	CRC Builders Fill Two part exterior grade fill to finish over jolt head nails		

14 Details

Various details outlined in the following table are available on Pages 15 to 42.

Table 9

Details				
Description	Direct fixed		Timber Cavity Batten Construction	
	Figure	Page	Figure	Page
Foundation detail and soffit detail	Figure 1	15		
Weatherboard fixing	Figure 2	15	Figure 29	27
Boxed corner	Figure 3 & 4	16	Figure 30	28
Mitre corner	Figure 5	17	Figure 31	28
Aluminium box corner	Figure 6	17	Figure 32	28
External corner soaker	Figure 7	18	Figure 33	29
Internal corner	Figure 8	18	Figure 34	29
Internal 90° aluminium 'W' mould corner	Figure 9	19	Figure 35	30
Internal 135° aluminium 'W' mould corner	Figure 10	19	Figure 36	30
Window sill with facings			Figure 38	31
Window sill with sill tray and facings	Figure 11	20		
Window door and head with facings	Figure 12	20	Figure 39	32
Window door and jamb with facings	Figure 13	20	Figure 40	32
Window door and sill without facings	Figure 14	21	Figure 41	32
Window door and head without facings	Figure 15	21	Figure 42	33
Window door and jamb without facings	Figure 16	21	Figure 43	33
Head flashing termination	Figure 17	22	Figure 44	34
One piece apron flashing joint	Figure 18	22	Figure 45	35
Pipe penetration	Figure 19	23	Figure 47	36
Meter box at head	Figure 20	23	Figure 48	37
Meter box at sill	Figure 21	23	Figure 49	37
Meter box at jamb	Figure 22	24	Figure 50	37
Timber cavity fix meter box			Figure 51	38
Deck junction	Figure 23	24	Figure 58	43
Cantilevered timber deck junction	Figure 24	25	Figure 59	43
Sloping soffit to weatherboard junction	Figure 25	25	Figure 57	42
Timber cavity batten fixing			Figure 26	26
Foundation detail			Figure 27	26
Soffit detail			Figure 28	27
Batten layout at window opening			Figure 37	31
One piece gutter/wall junction			Figure 46	36
Drainage joint			Figure 52	39
Enclosed deck balustrade to wall			Figure 53	40
Enclosed balustrade to wall			Figure 54	40
Enclosed deck	Figure 55	41	Figure 55	41
Parapet flashing			Figure 56	42
Timber deck junction			Figure 60	44
Door sill support detail			Figure 61	44
Junction between Linea® Weatherboard and fascia board			Figure 62	45
Enclosed roof to wall intersection			Figure 63	46

Figure 1: Direct fix foundation detail and soffit detail

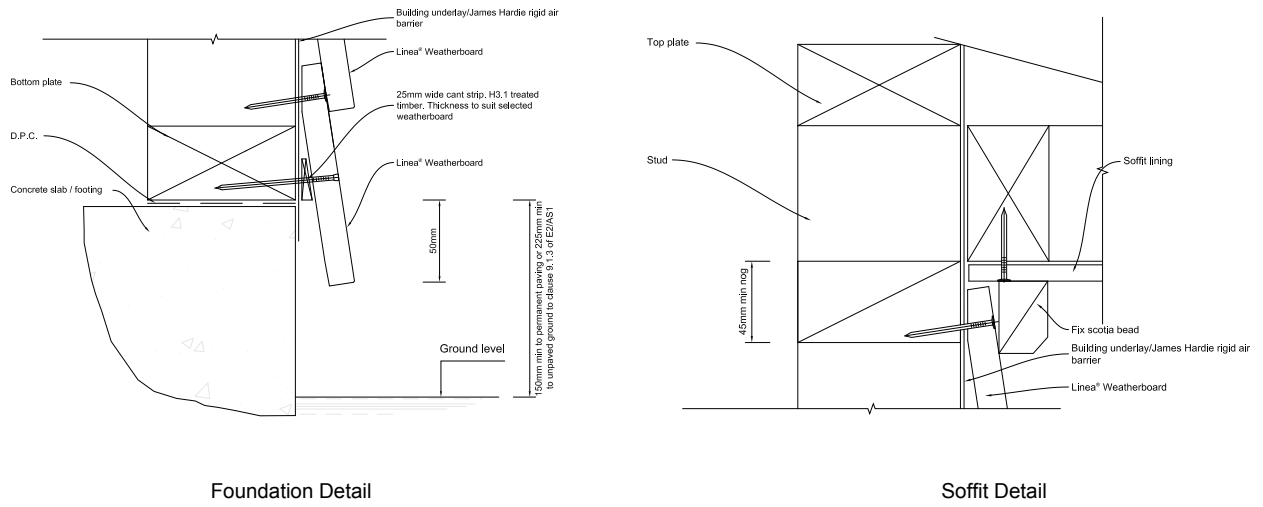

Figure 2: Direct fix weatherboard fixing

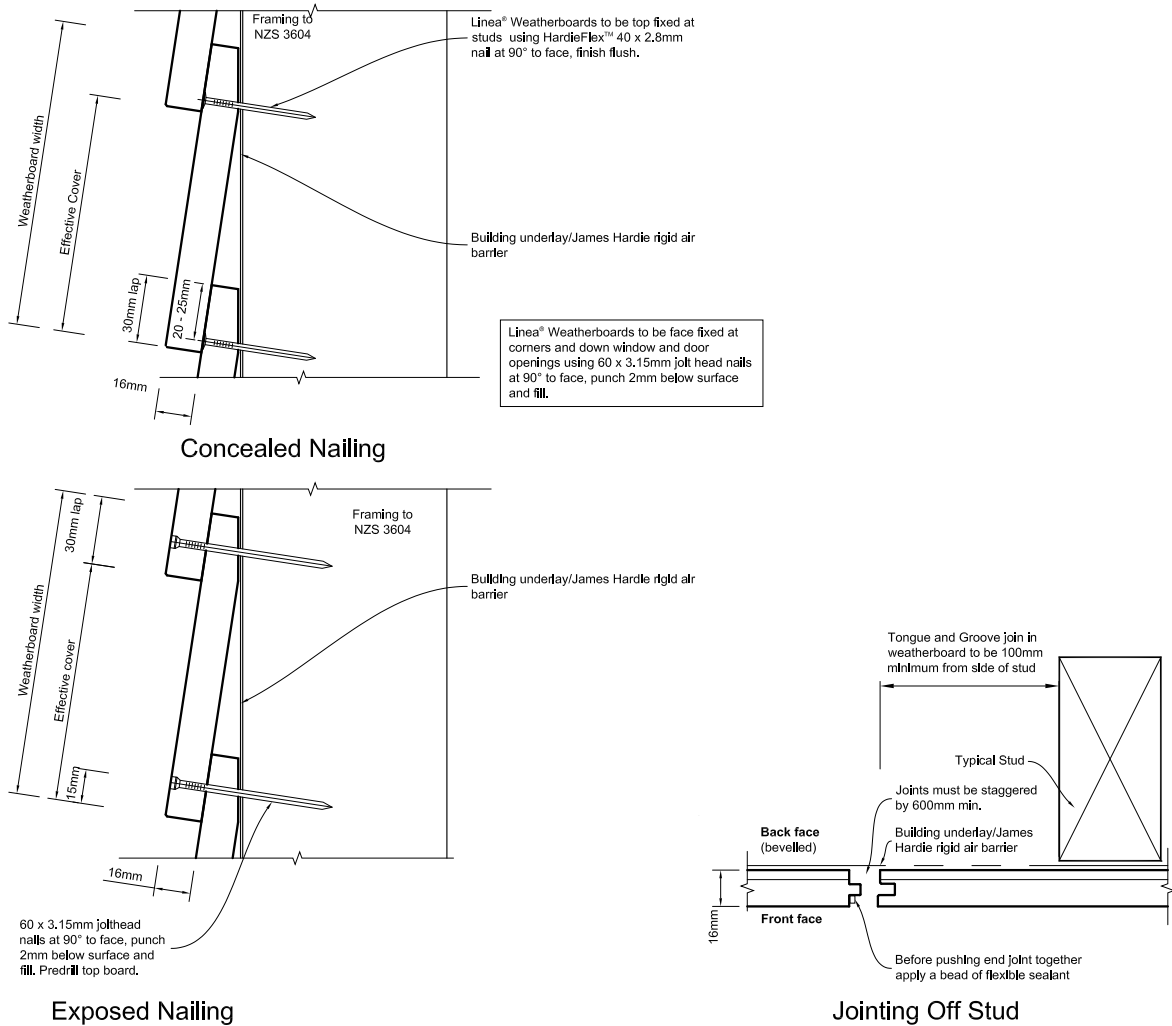

Figure 3: Direct fix boxed corner - Option 1

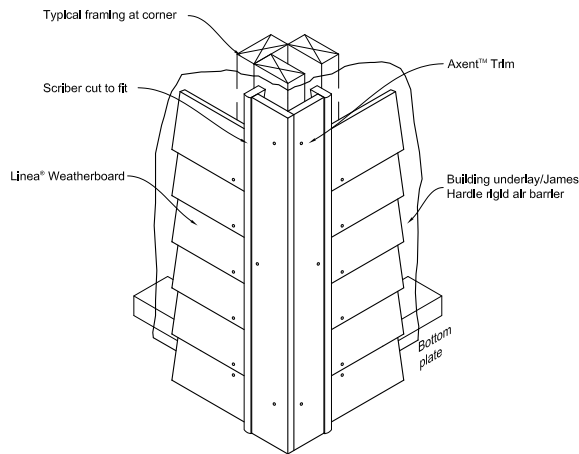
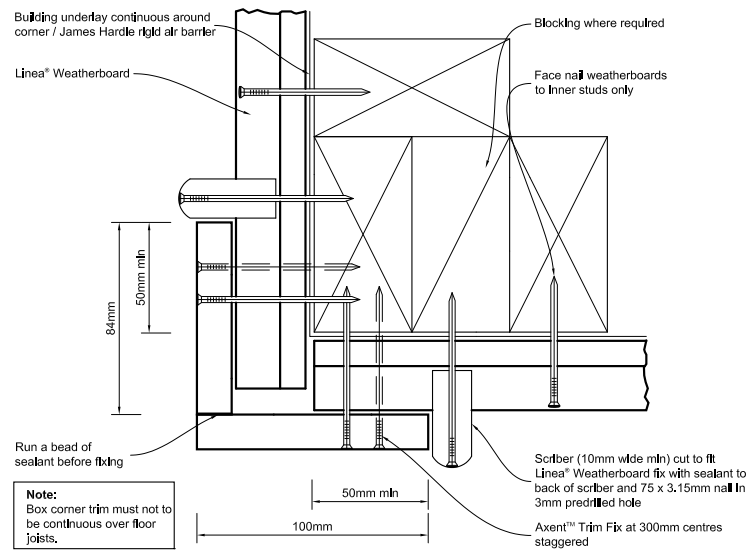

Figure 4: Direct fix boxed corner - Option 2

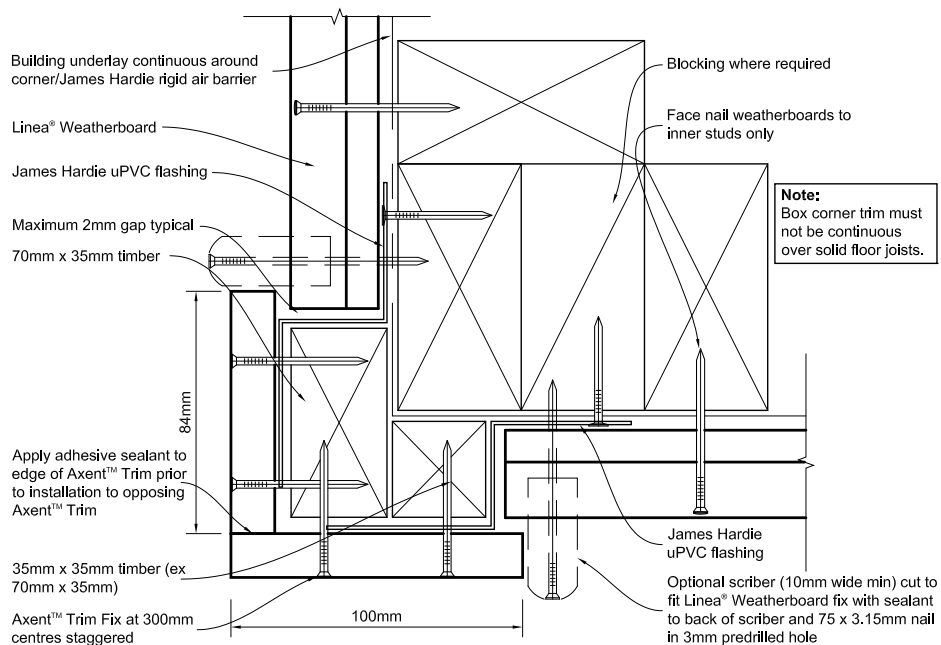

Figure 5: Direct fix mitre corner

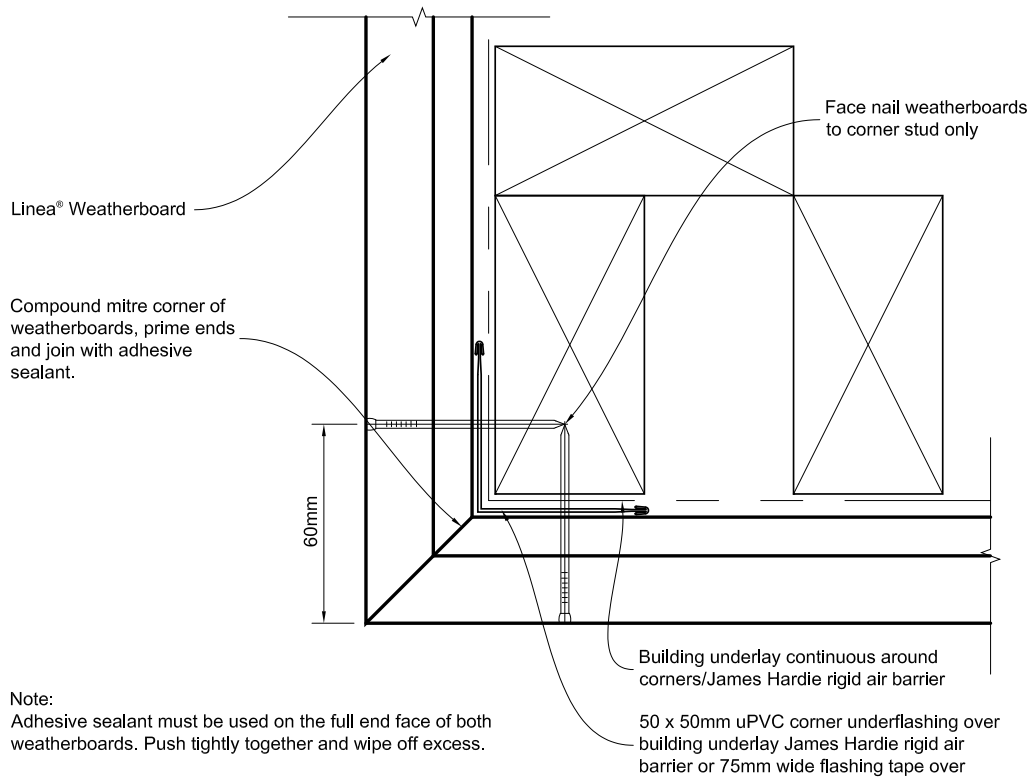
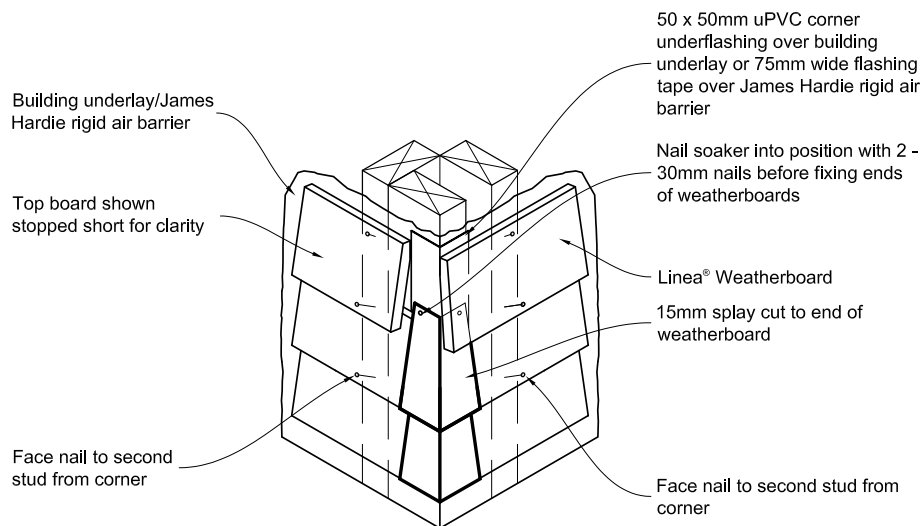
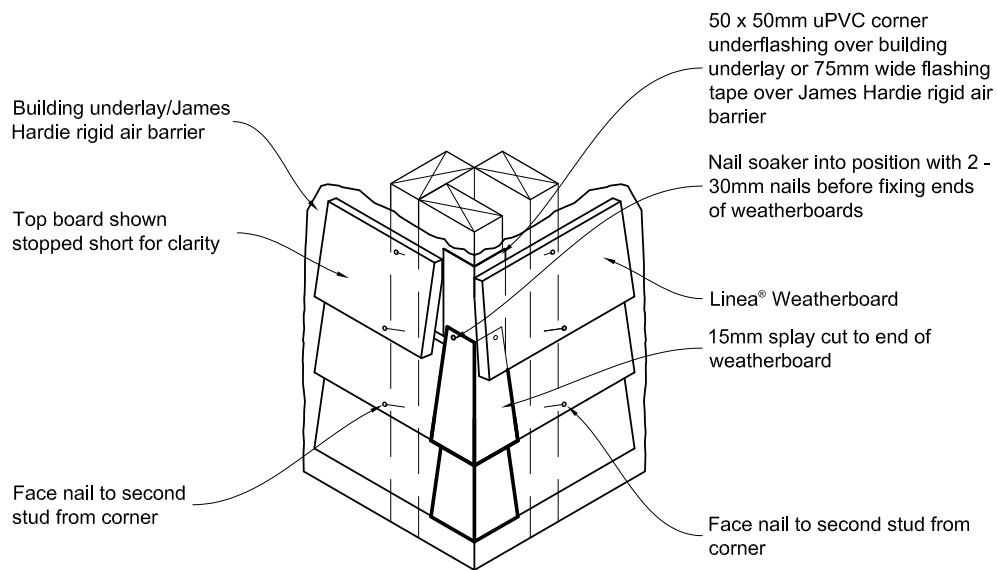

Figure 6: Direct fix aluminium box corner



Soaker material	Nail material
Copper	Copper or phosphor bronze
Aluminium	Hot dip galvanised
Stainless steel	Stainless steel

Figure 7: Direct fix external corner soaker



Soaker material	Nail material
Copper	Copper or phosphor bronze
Aluminium	Hot dip galvanised
Stainless steel	Stainless steel

Figure 8: Direct fix internal corner

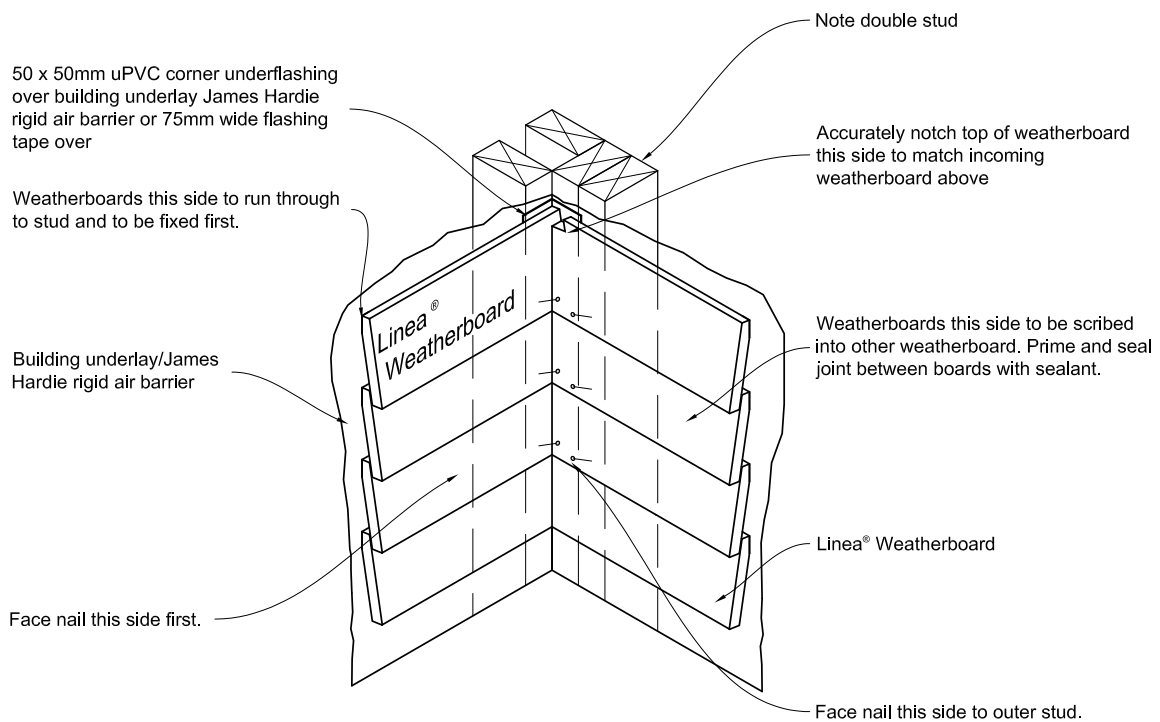

Figure 9: Direct fix internal 90° aluminium 'W' mould corner

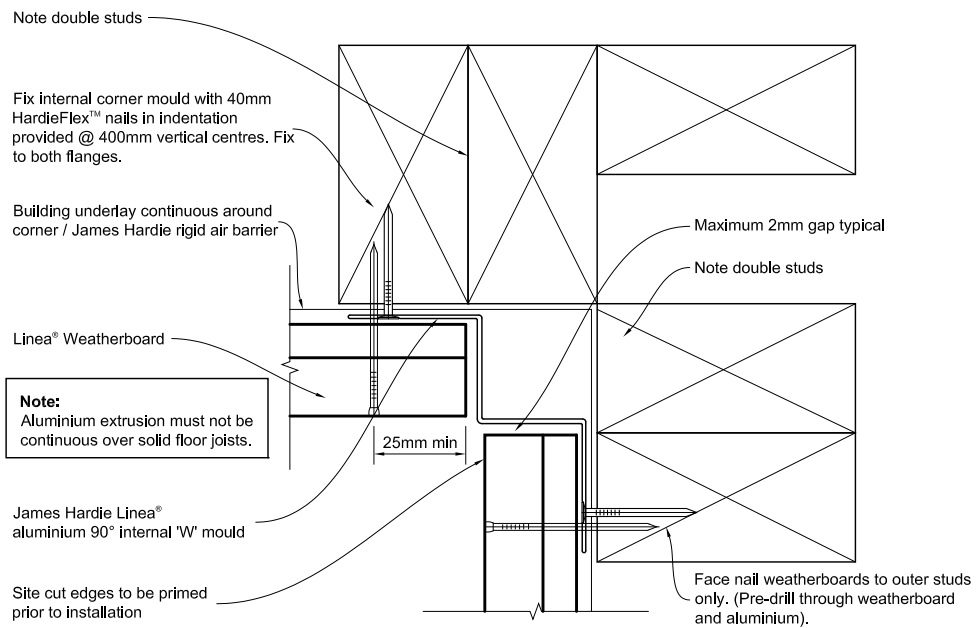

Figure 10: Direct fix internal 135° aluminium 'W' mould corner

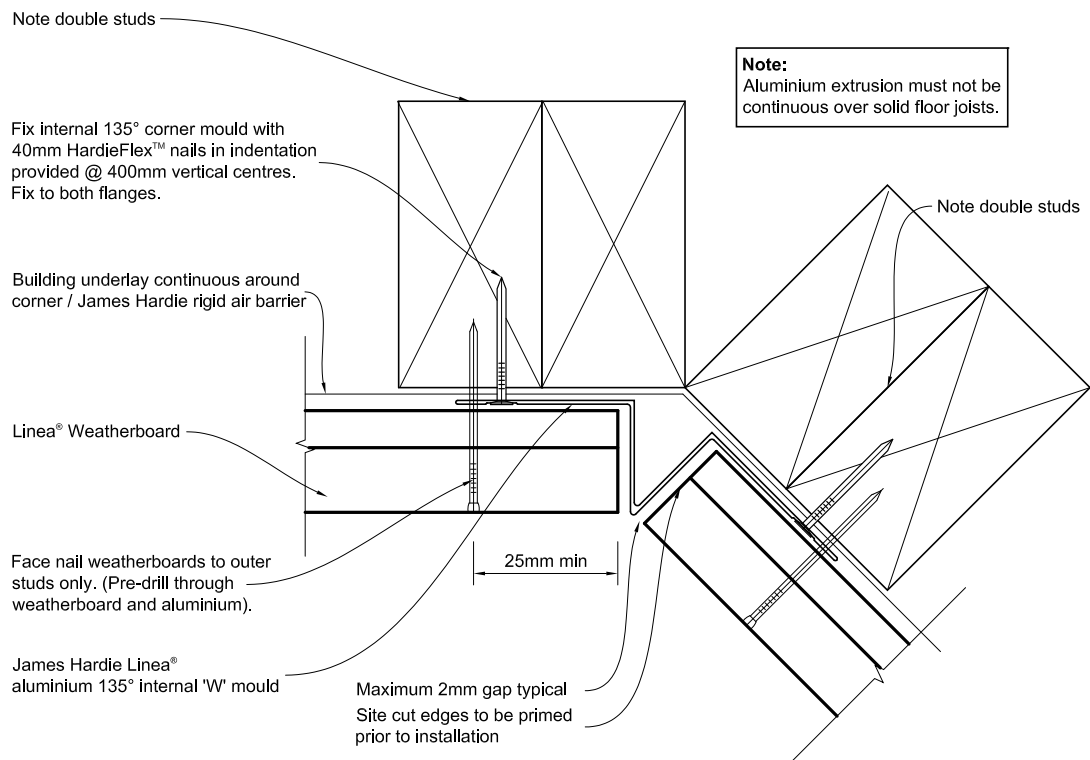
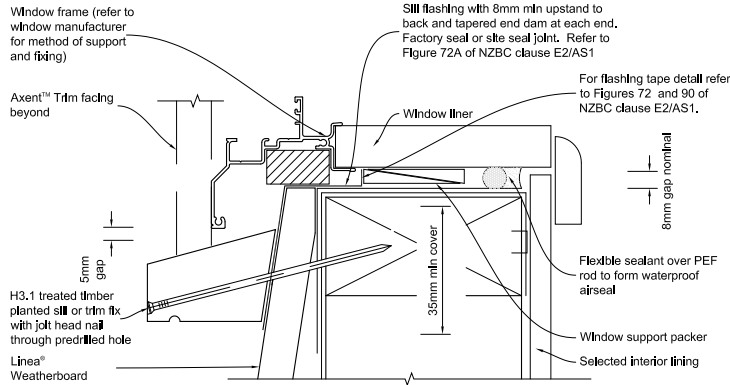

Figure 11: Direct fix window sill flashing sill tray and facings



General notes for materials selection

1. Flashing materials must be selected based on environmental exposure, refer to NZS 3604 and Table 20 of NZBC clause E2/AS1.
2. Building underlay must comply with acceptable solution NZBC clause E2/AS1.
3. Flashing tape must have proven compatibility with the selected building underlay/James Hardie rigid air barrier and other materials with which it comes into contact as per Table 21 of NZBC clause E2/AS1.

Refer to the manufacturer or supplier for technical information for these materials.

Figure 12: Direct fix window head and door with facings

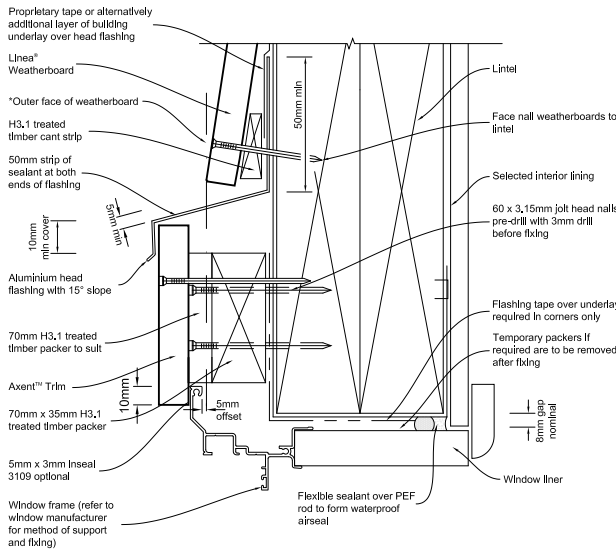

Note:
When James Hardie rigid air barrier is used flashing tape to be applied to the entire window opening. Sealant must be installed between head flashing and trim in VH wind zones. Refer to Figure 71 of E2/AS1

Figure 13: Direct fix window and door jamb with facings

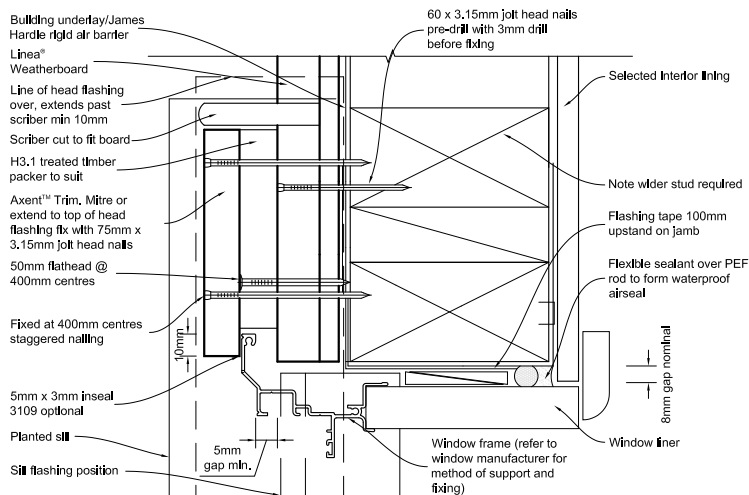

Note:
When James Hardie rigid air barrier is used flashing tape to be applied to the entire window opening.

Figure 14: Direct fix window and door sill without facings

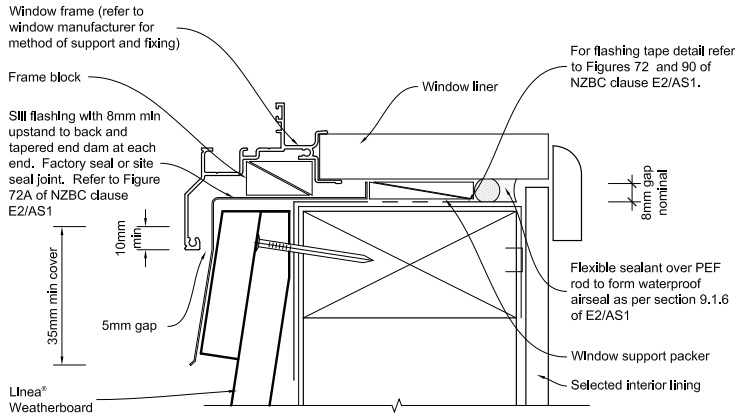

General notes for materials selection

1. Flashing materials must be selected based on environmental exposure, refer to NZS 3604 and Table 20 of NZBC clause E2/AS1.
 2. Building underlay must comply with acceptable solution NZBC clause E2/AS1.
 3. Flashing tape must have proven compatibility with the selected building underlay/James Hardie rigid air barrier and other materials with which it comes into contact as per Table 21 of NZBC clause E2/AS1.
- Refer to the manufacturer or supplier for technical information for these materials.

Figure 15: Direct fix window and door head without facings

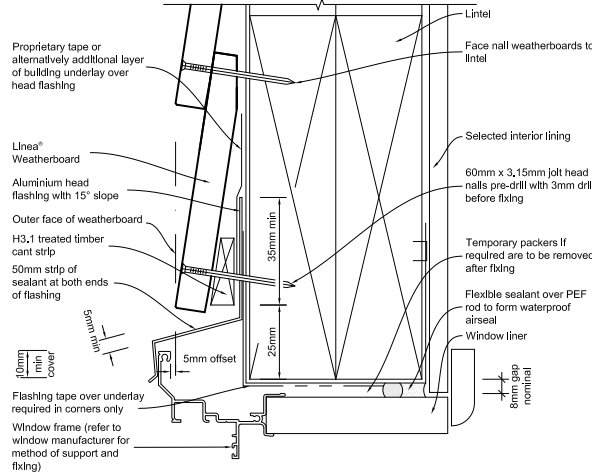

Note:
When James Hardie rigid air barrier is used flashing tape to be applied to the entire window opening. Sealant must be installed between head flashing and window flange in VH wind zones. Refer Figure 71 of E2/AS1

Figure 16: Direct fix window and door jamb without facings

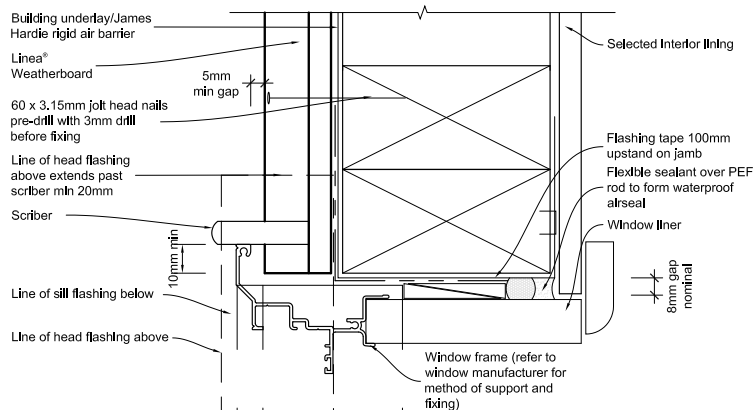

Note:
When James Hardie rigid air barrier is used flashing tape to be applied to the entire window opening. Alternatively window jamb can be formed as per E2/AS1 with jamb battens.

Figure 17: Direct fix head flashing termination

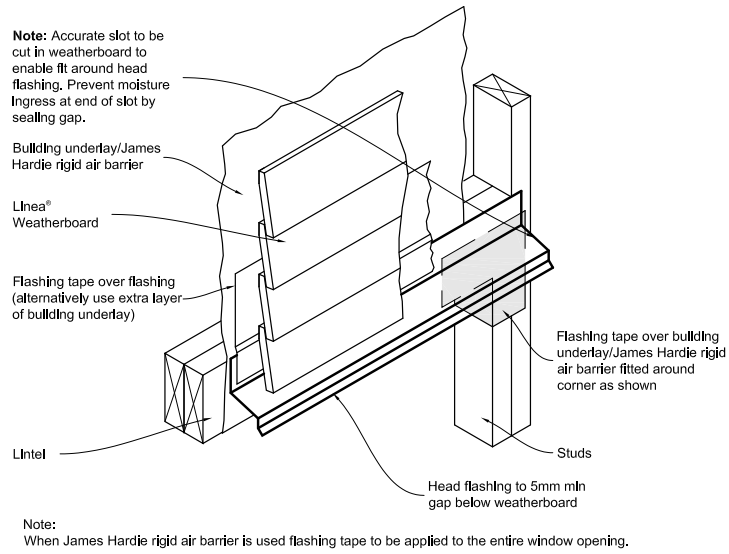

Figure 18: Direct fix one piece apron flashing joint

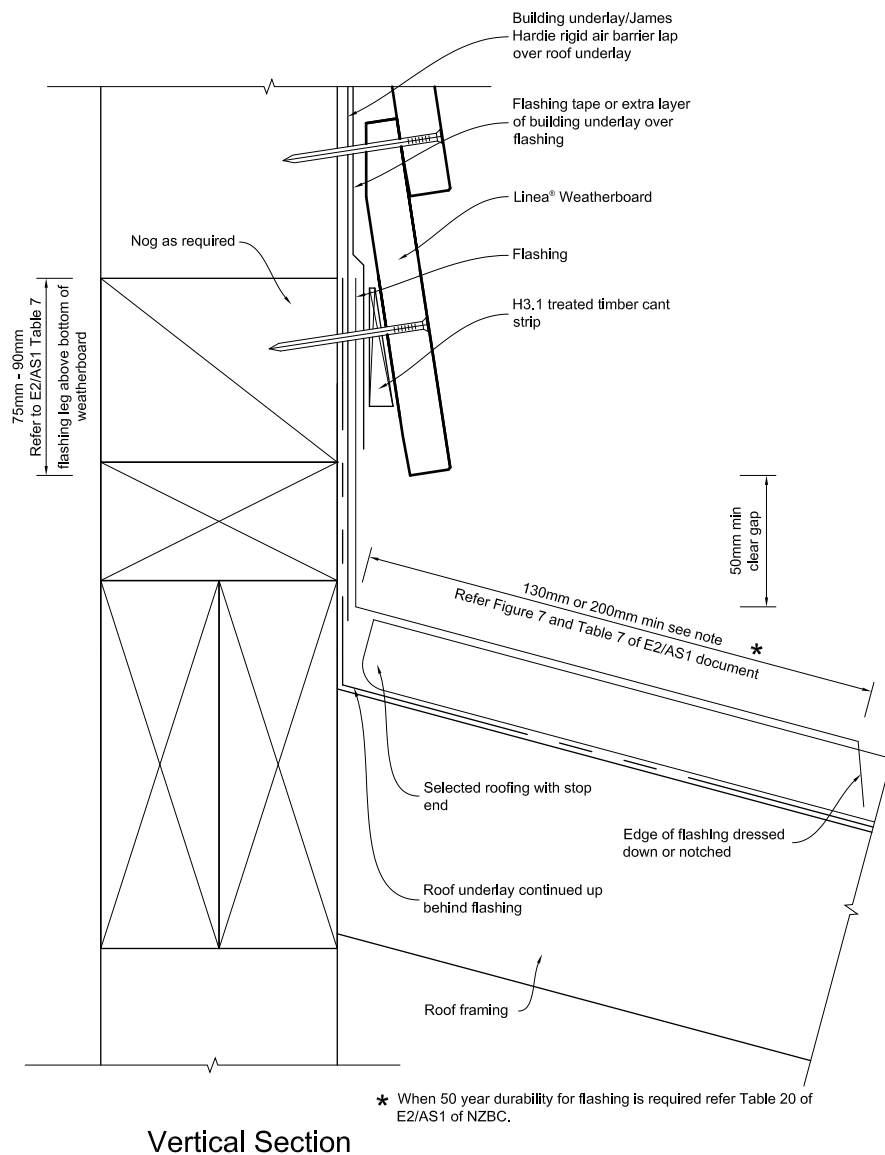

Figure 19: Direct fix pipe penetration

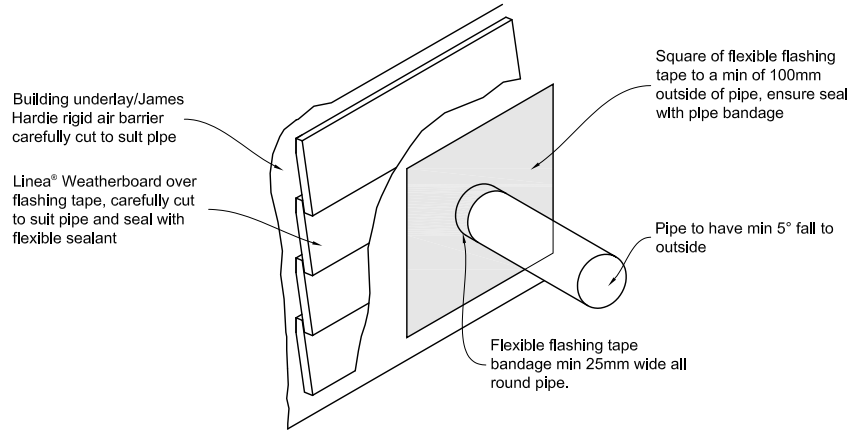
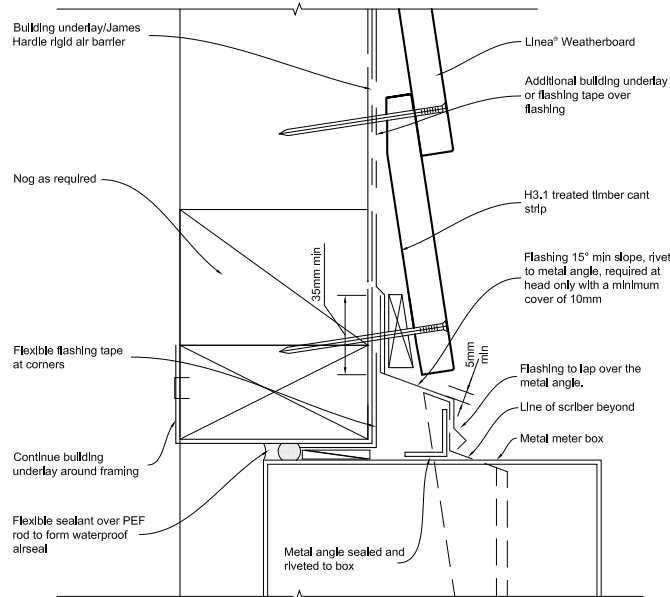
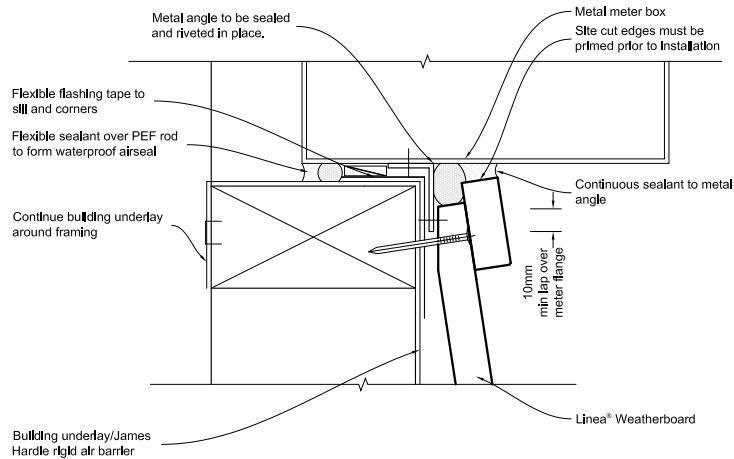

Figure 20: Direct fix meter box at head



Note:
When James Hardie rigid air barrier is used flashing tape to be applied to the entire opening.

Figure 21: Direct fix meter box at sill



Note:
When James Hardie rigid air barrier is used flashing tape to be applied to the entire opening.

Figure 22: Direct fix meter box at jamb

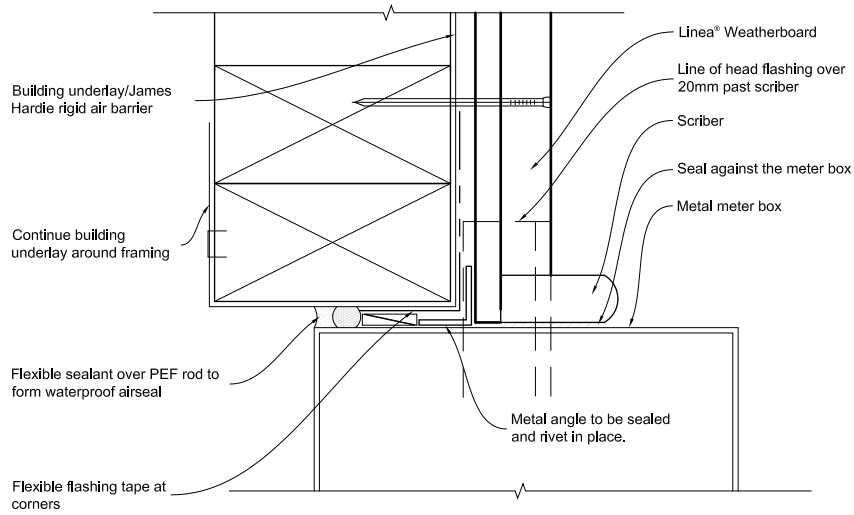

Note:
When James Hardie rigid air barrier is used flashing tape to be applied to the entire opening.

Figure 23: Direct fix deck junction

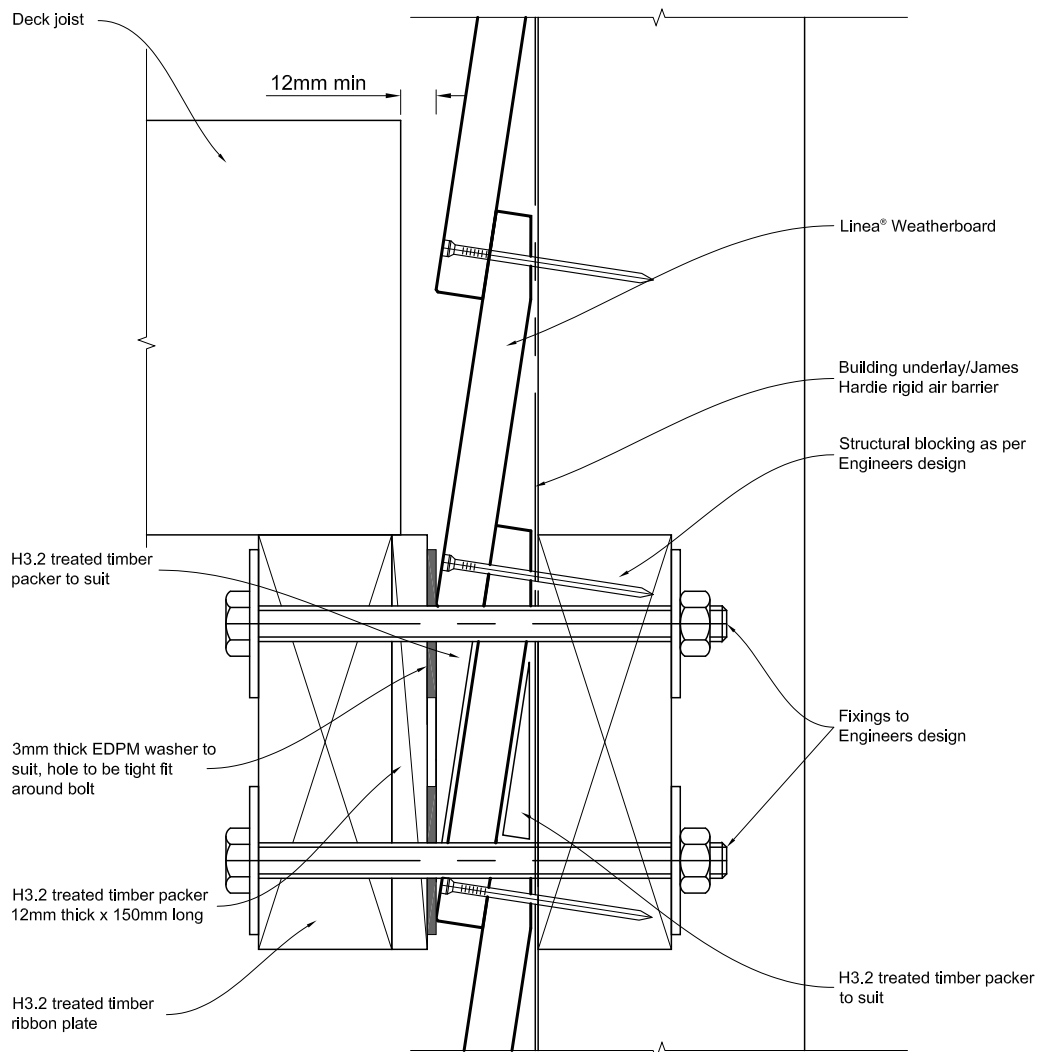

Figure 24: Direct fix cantilever deck junction

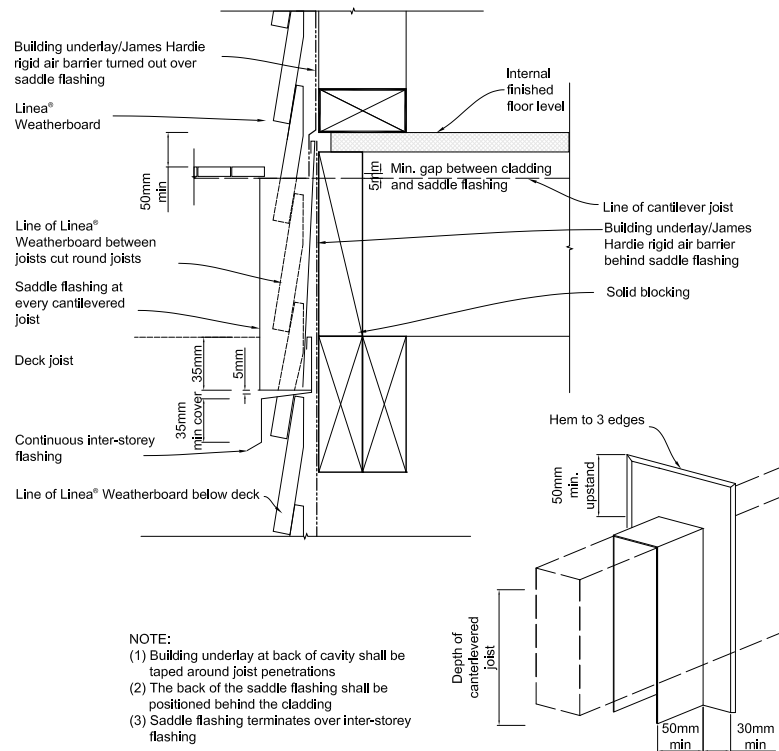

Figure 25: Sloping soffit to weatherboard junction combined figure

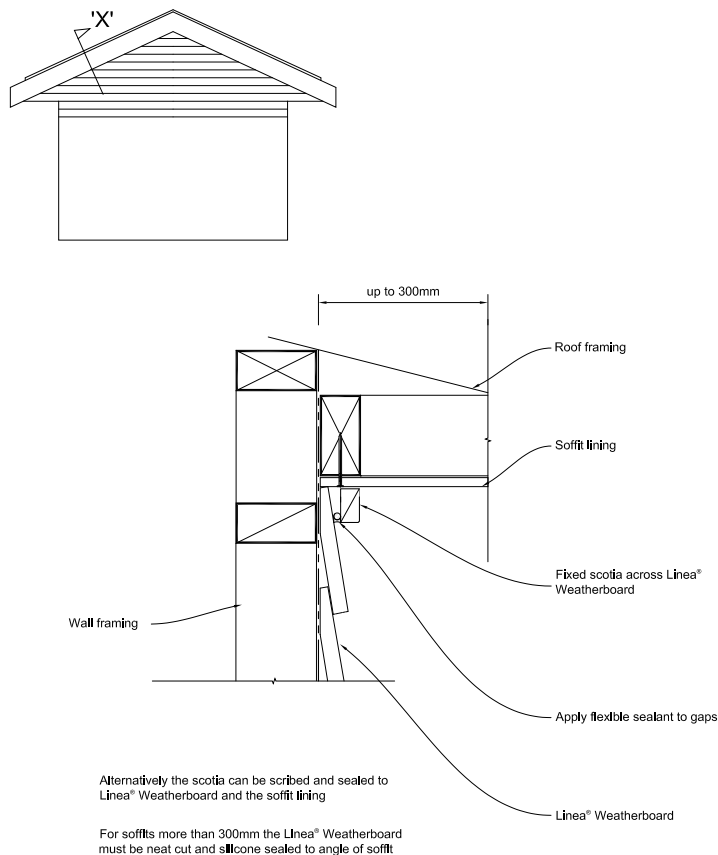

Figure 26: Timber cavity batten fixing

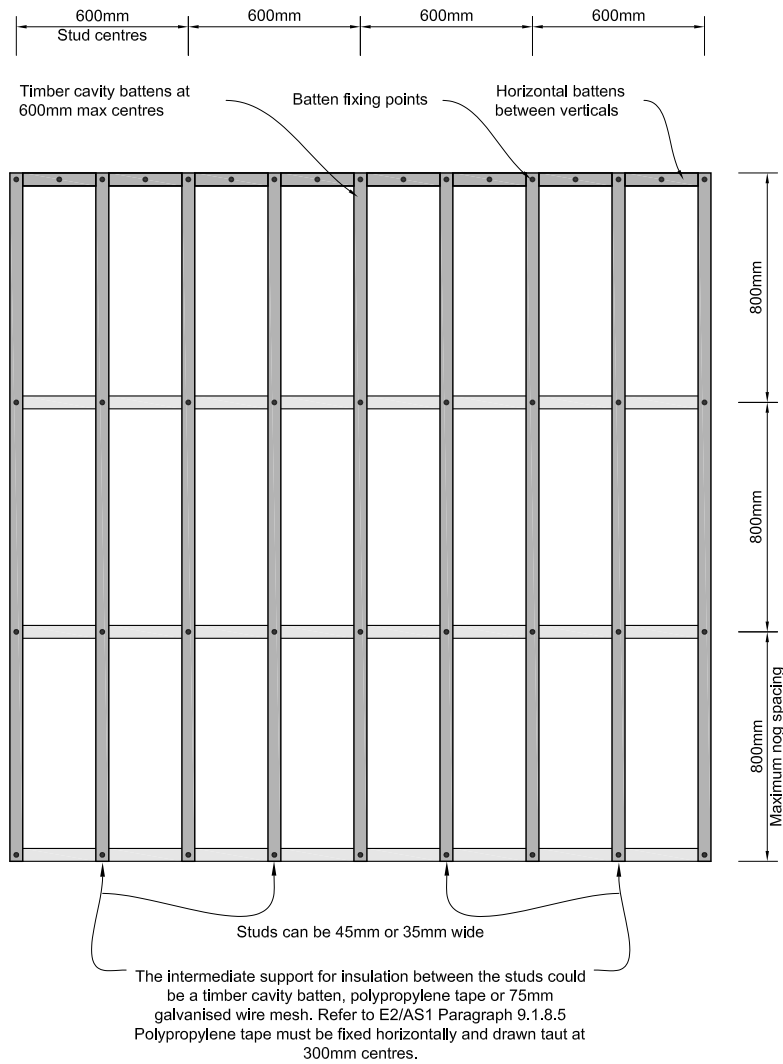

Figure 27: Timber cavity foundation detail

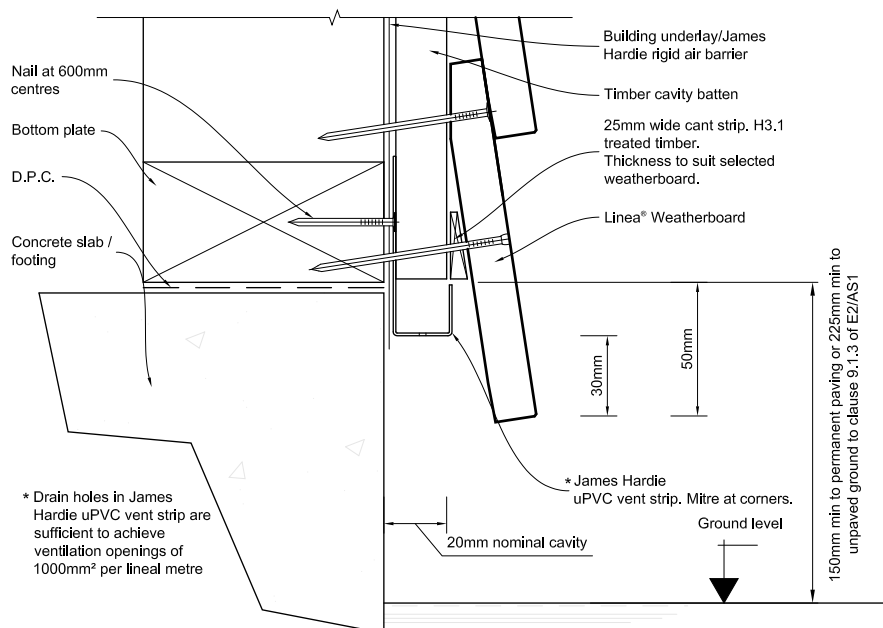

Figure 28: Timber cavity soffit detail

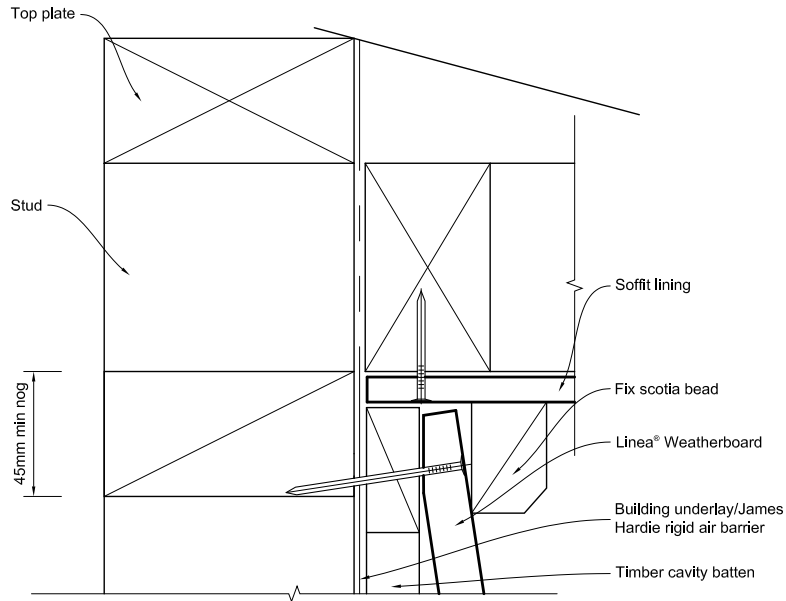
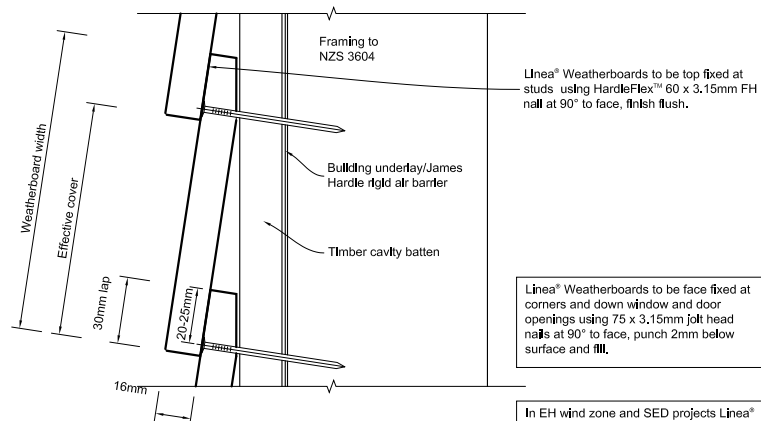
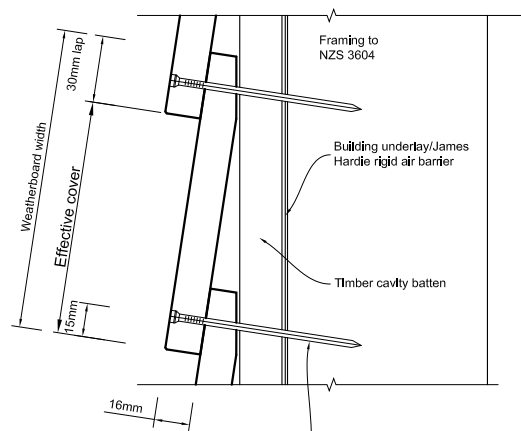

Figure 29: Timber cavity weatherboard fixing



Concealed Nailing



75 x 3.15mm jolt head nails at 90° to face. Punch 2mm below surface and fill. Pre-drill top board.

Exposed Nailing

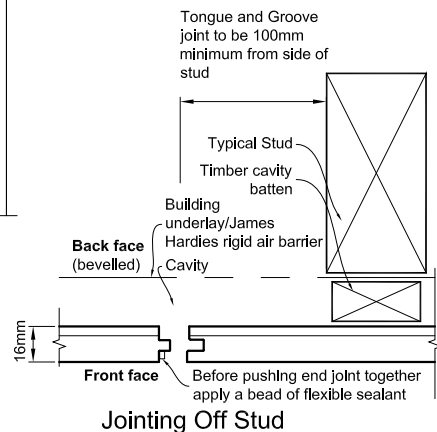

Jointing Off Stud

Figure 30: Timber cavity boxed corner

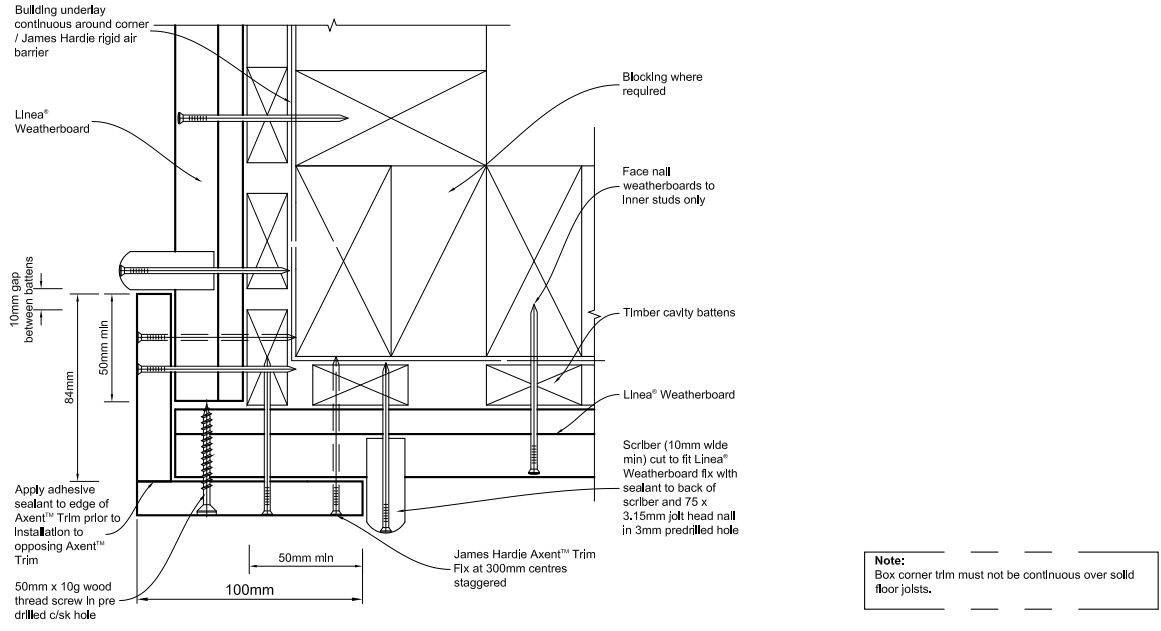

Figure 31: Timber cavity mitre corner

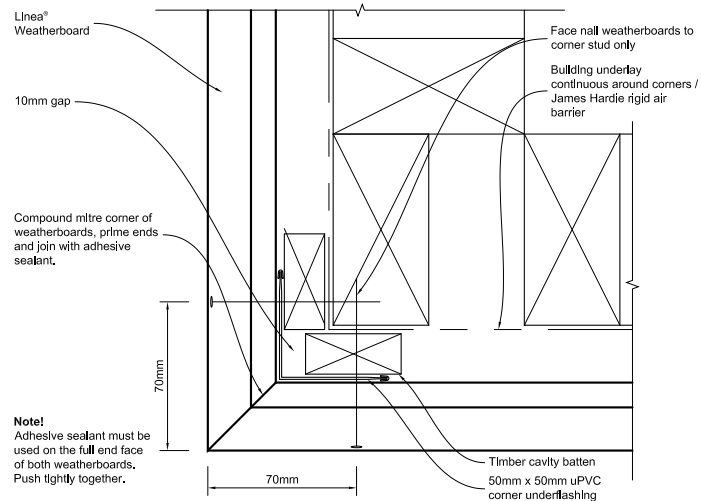

Figure 32: Timber cavity aluminium box corner

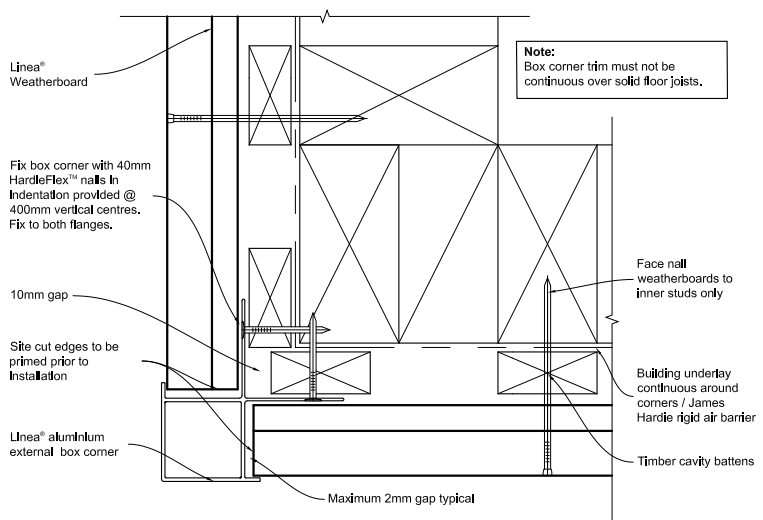
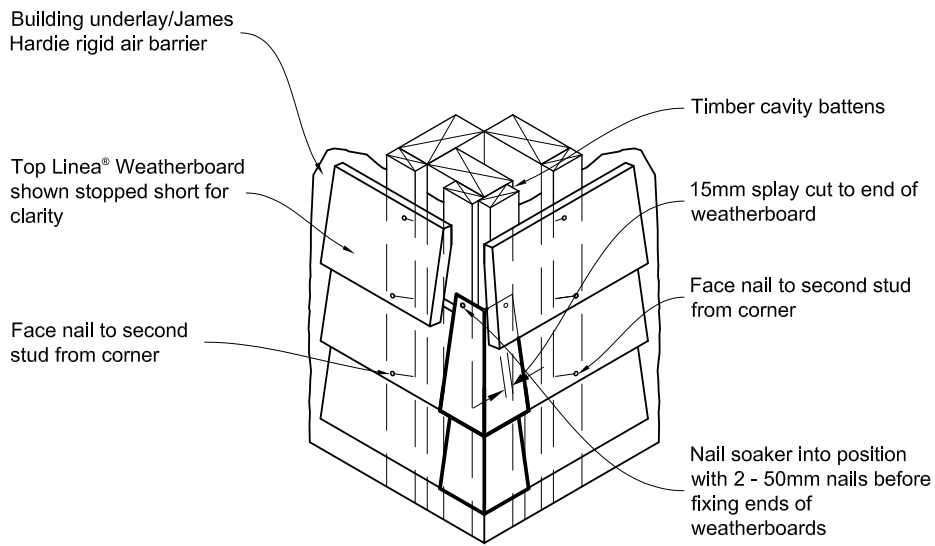

Figure 33: Timber cavity external corner soaker



Soaker material	Nail material
Copper	Copper or phosphor bronze
Aluminium	Hot dip galvanised
Stainless steel	Stainless steel

Figure 34: Timber cavity internal corner

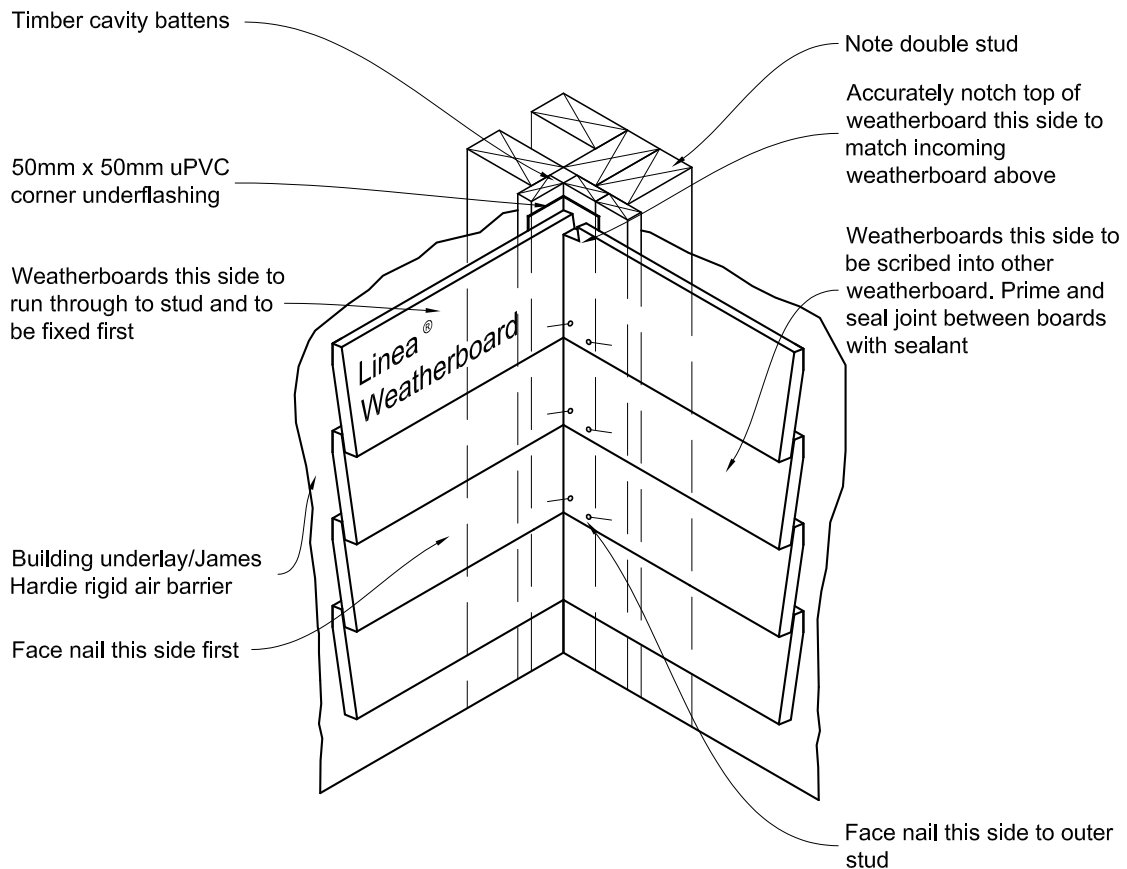

Figure 35: Timber cavity internal 90° aluminium 'W' mould corner

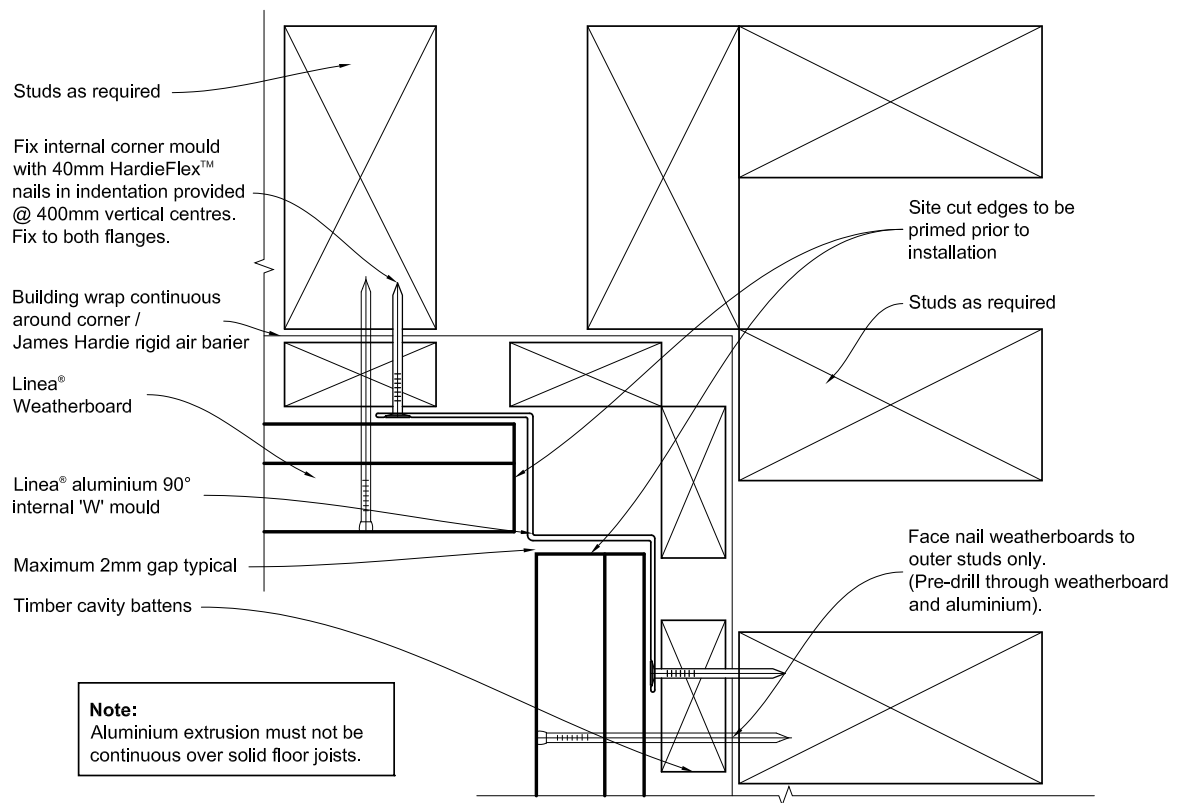

Figure 36: Timber cavity internal 135° aluminium 'W' mould corner

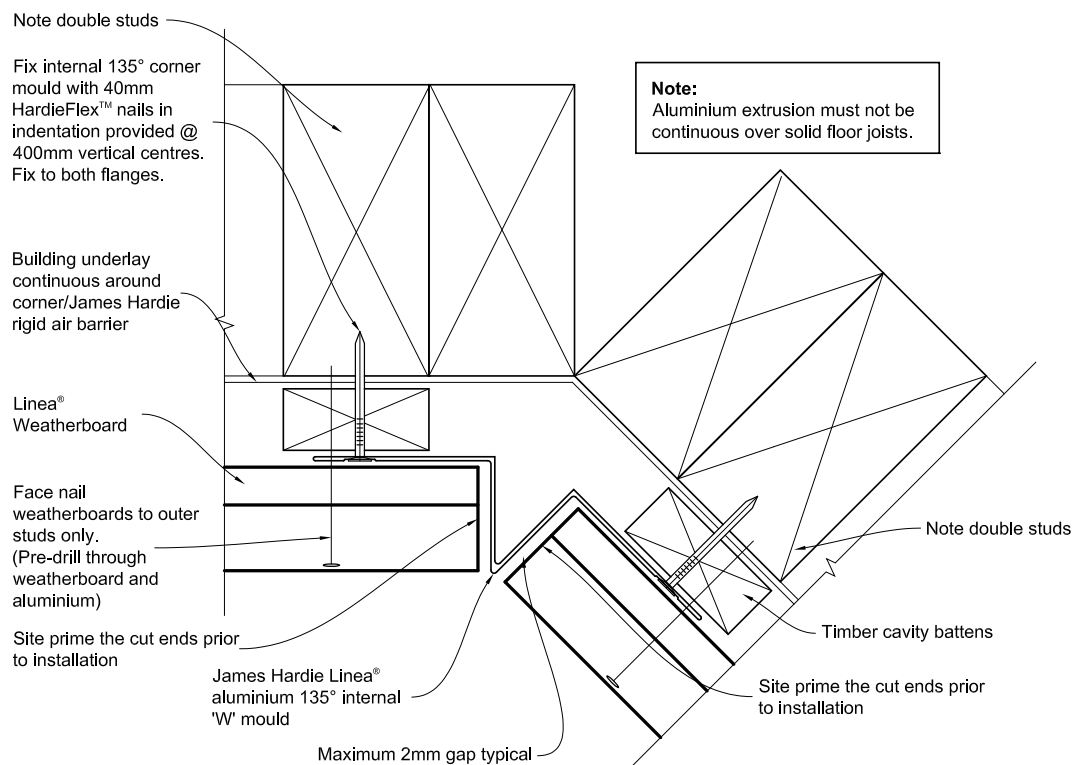

Figure 37: Timber cavity batten layout at window opening

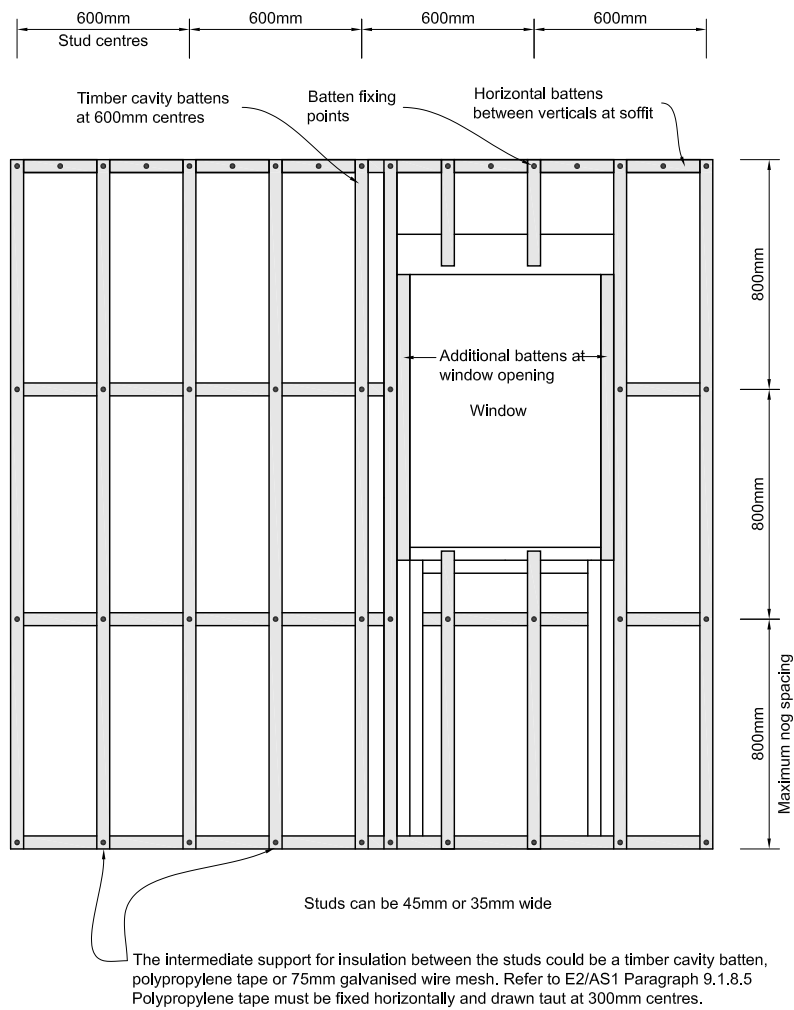
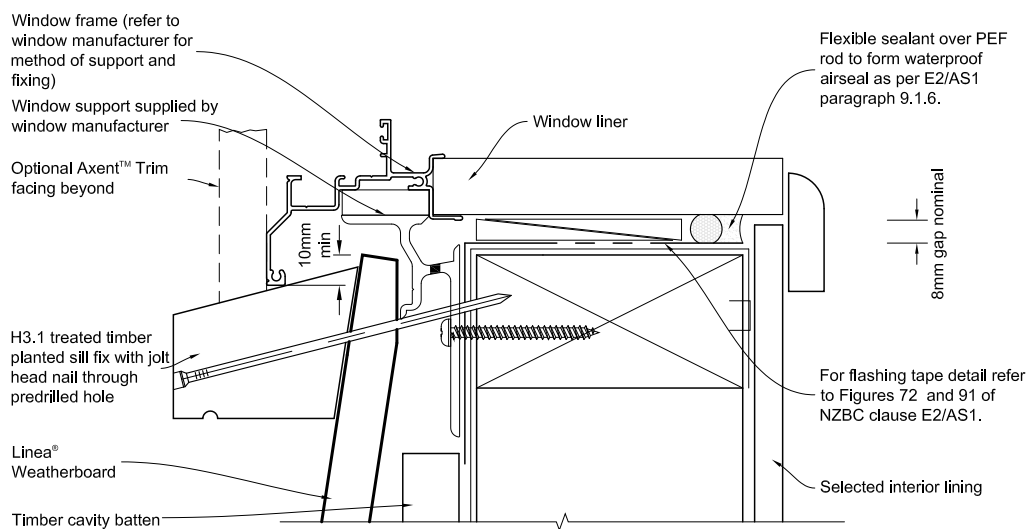

Figure 38: Timber cavity window sill with facings



General notes for materials section

1. Flashing materials must be selected based on environmental exposure, refer to NZS 3604 and Table 20 of NZBC clause E2/AS1.
2. Building underlay must comply with acceptable solution NZBC clause E2/AS1.
3. Flashing tape must have proven compatibility with the selected building underlay / James Hardie rigid air barrier and other materials with which it comes into contact as per Table 21 of NZBC clause E2/AS1.

Refer to the manufacturer or supplier for technical information for these materials.

Figure 39: Timber cavity window and door head with facings

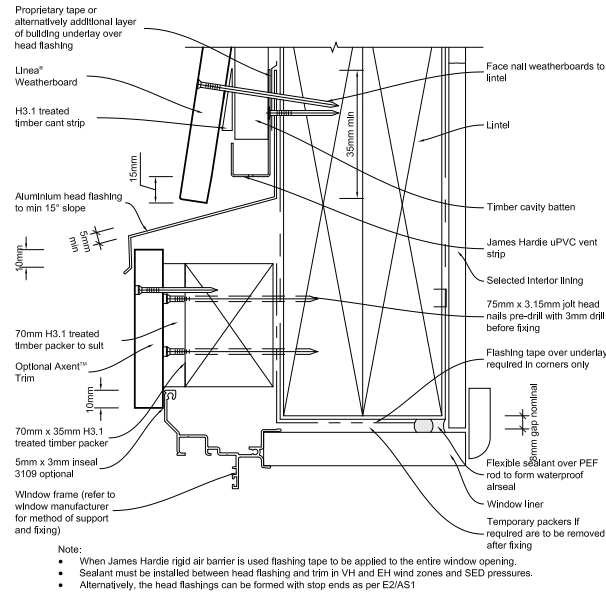

Figure 40: Timber cavity window and door jamb with facings

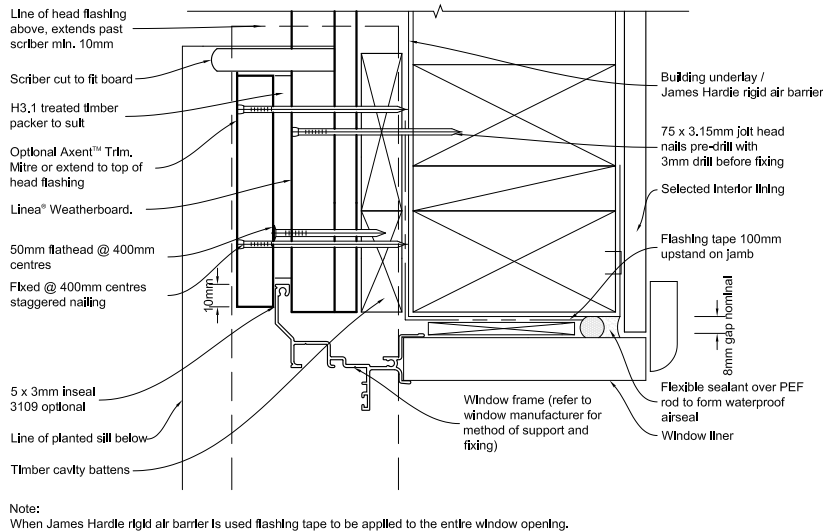
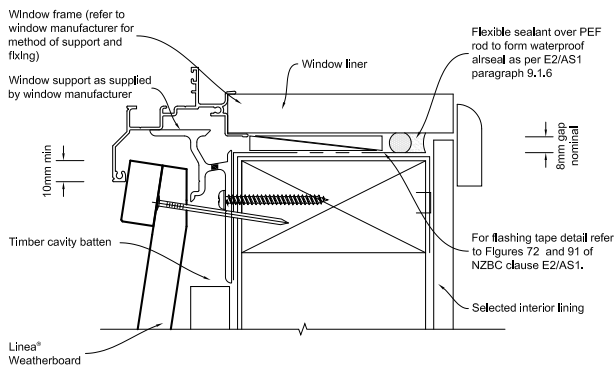

Figure 41: Timber cavity window and door sill without facings



General notes for materials selection

1. Flashing materials must be selected based on environmental exposure, refer to NZS 3604 and Table 20 of NZBC clause E2/AS1.
2. Building underlay must comply with acceptable solution NZBC clause E2/AS1.
3. Flashing tape must have proven compatibility with the selected building underlay / James Hardies rigid air barrier and other materials with which it comes into contact as per Table 21 of NZBC clause E2/AS1.
4. Sill support bars must comply with EM6, E2/NM1 and B2/AS1. Refer to the manufacturer or supplier for technical information for these materials.

Figure 42: Timber cavity window and door head without facings

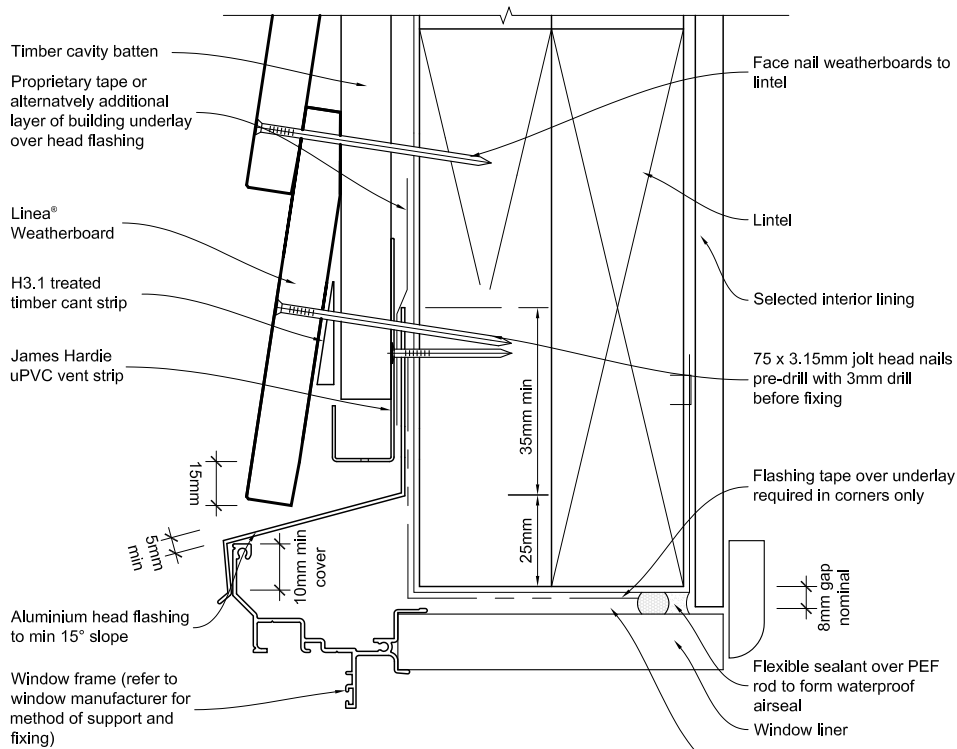

- Note:
- When James Hardie rigid air barrier is used flashing tape to be applied to the entire window opening.
 - Sealant must be installed between head flashing and flashing and trim in VH and EH wind zones and SED projects.
 - Alternatively, the head flashings can be formed with stop ends as per E2/AS1

Figure 43: Timber cavity window and door jamb without facings

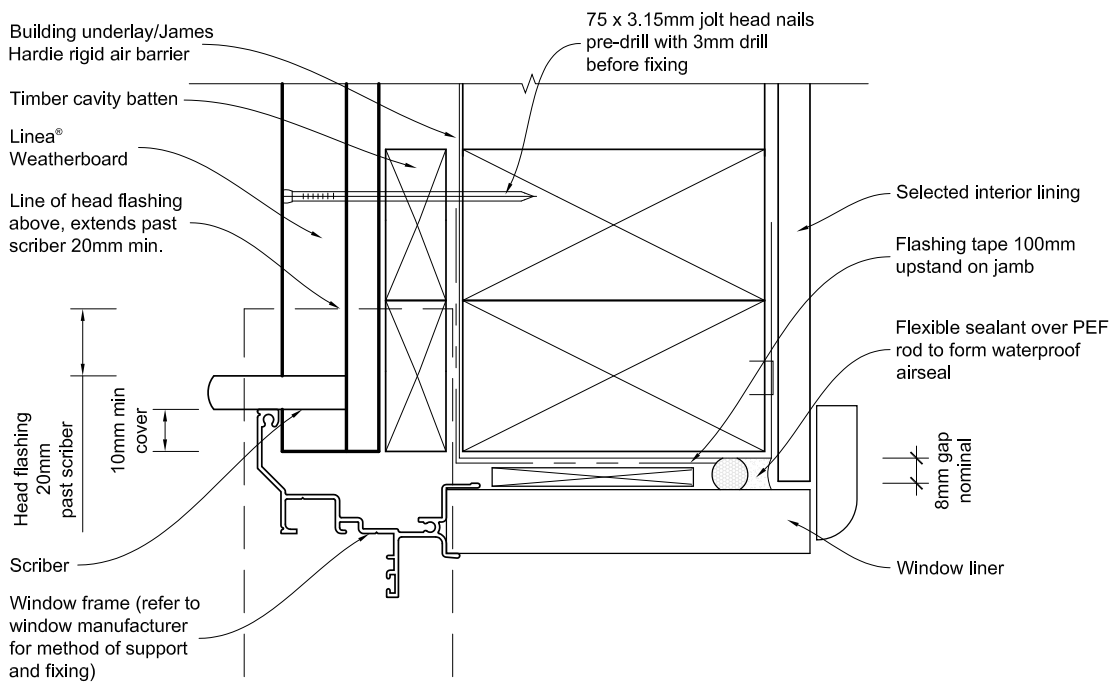

- Note:
- When James Hardie rigid air barrier is used flashing tape to be applied to the entire window opening.

Figure 44: Timber cavity head flashing termination

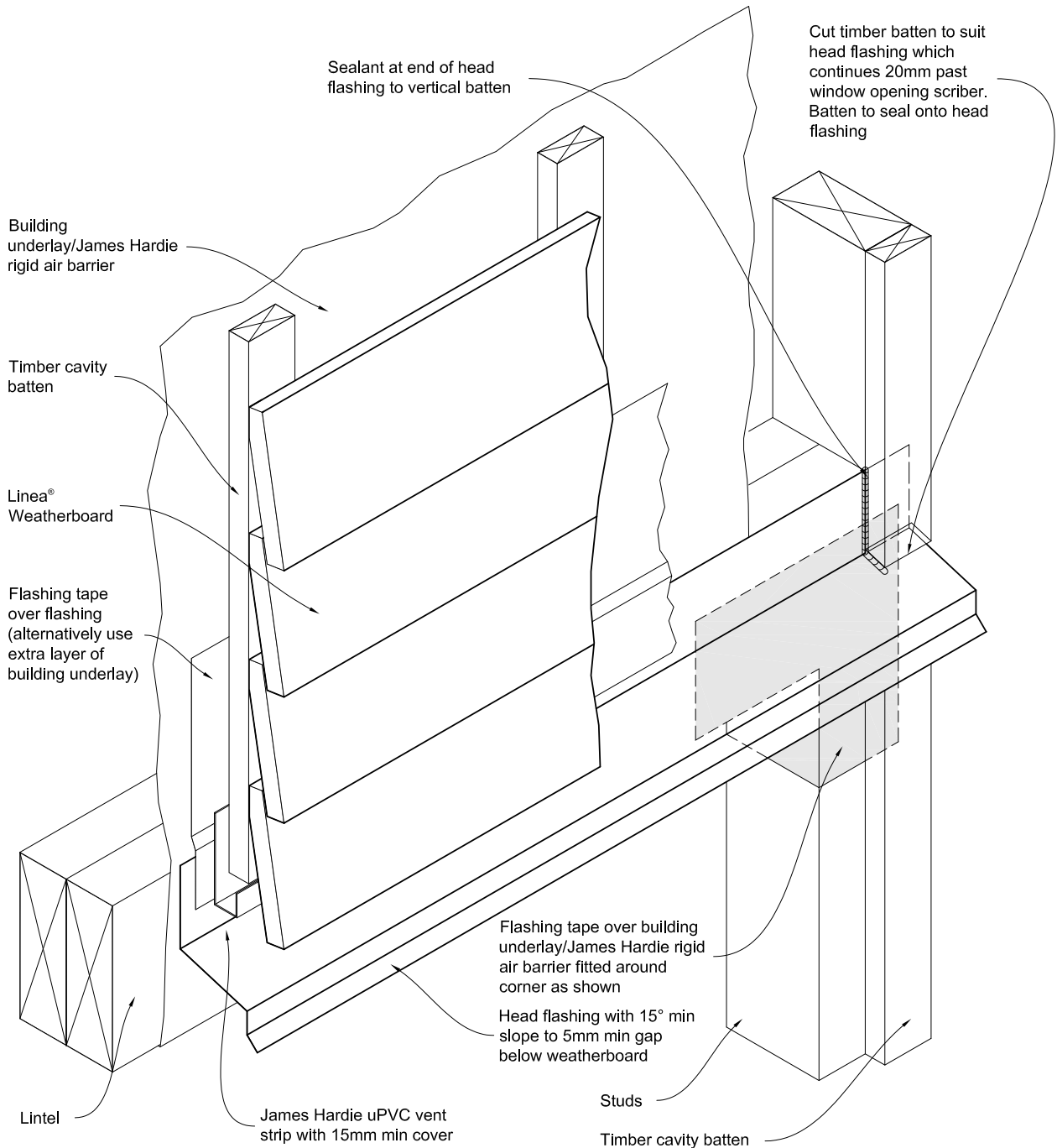

Note:
When James Hardie rigid air barrier is used flashing tape to be applied to the entire window opening.

Figure 45: Timber cavity one piece apron flashing joint

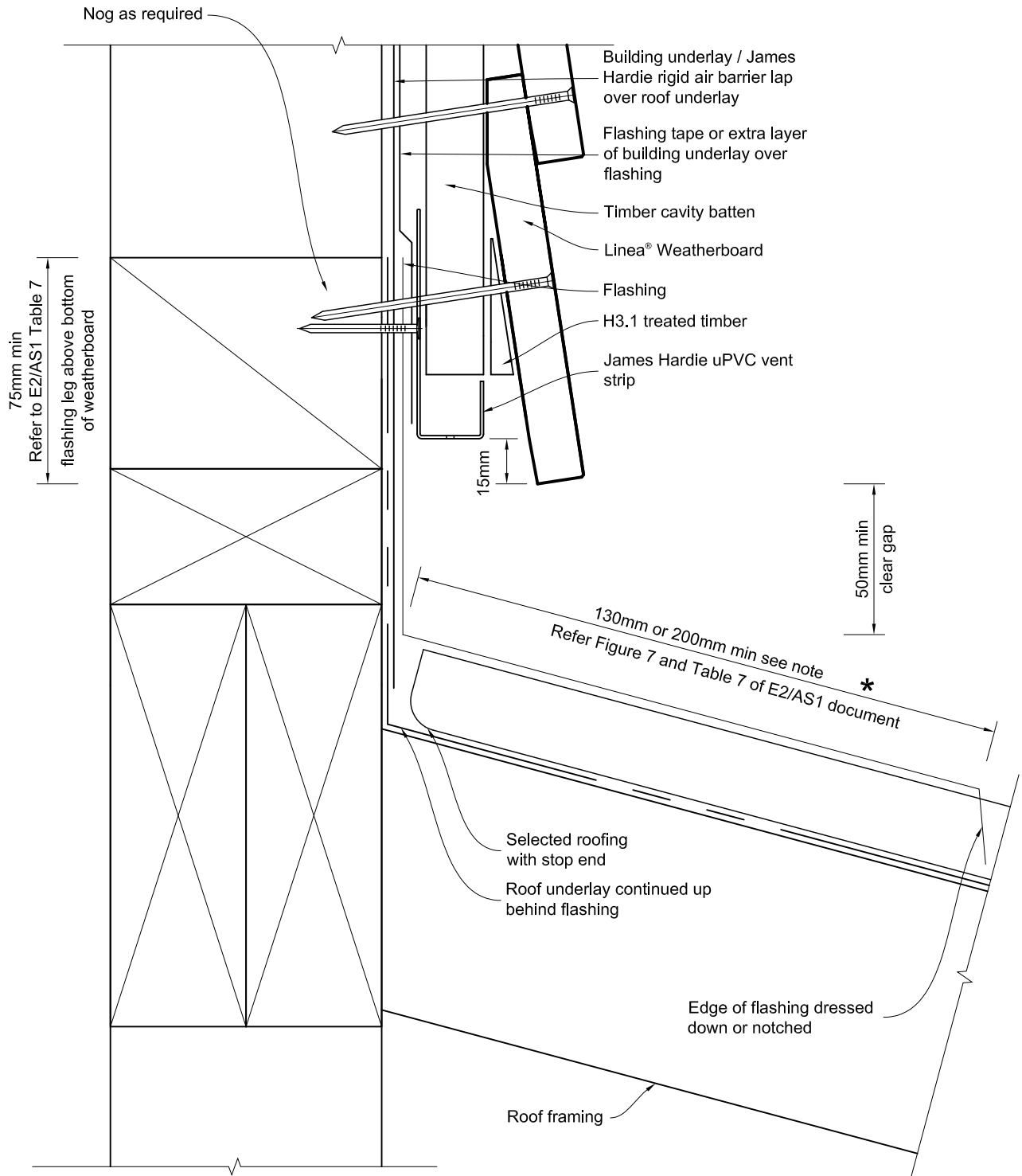

* When 50 year durability for flashing is required refer Table 20 of E2/AS1 of NZBC.

Vertical Section

Figure 46: Timber cavity one piece gutter/wall junction

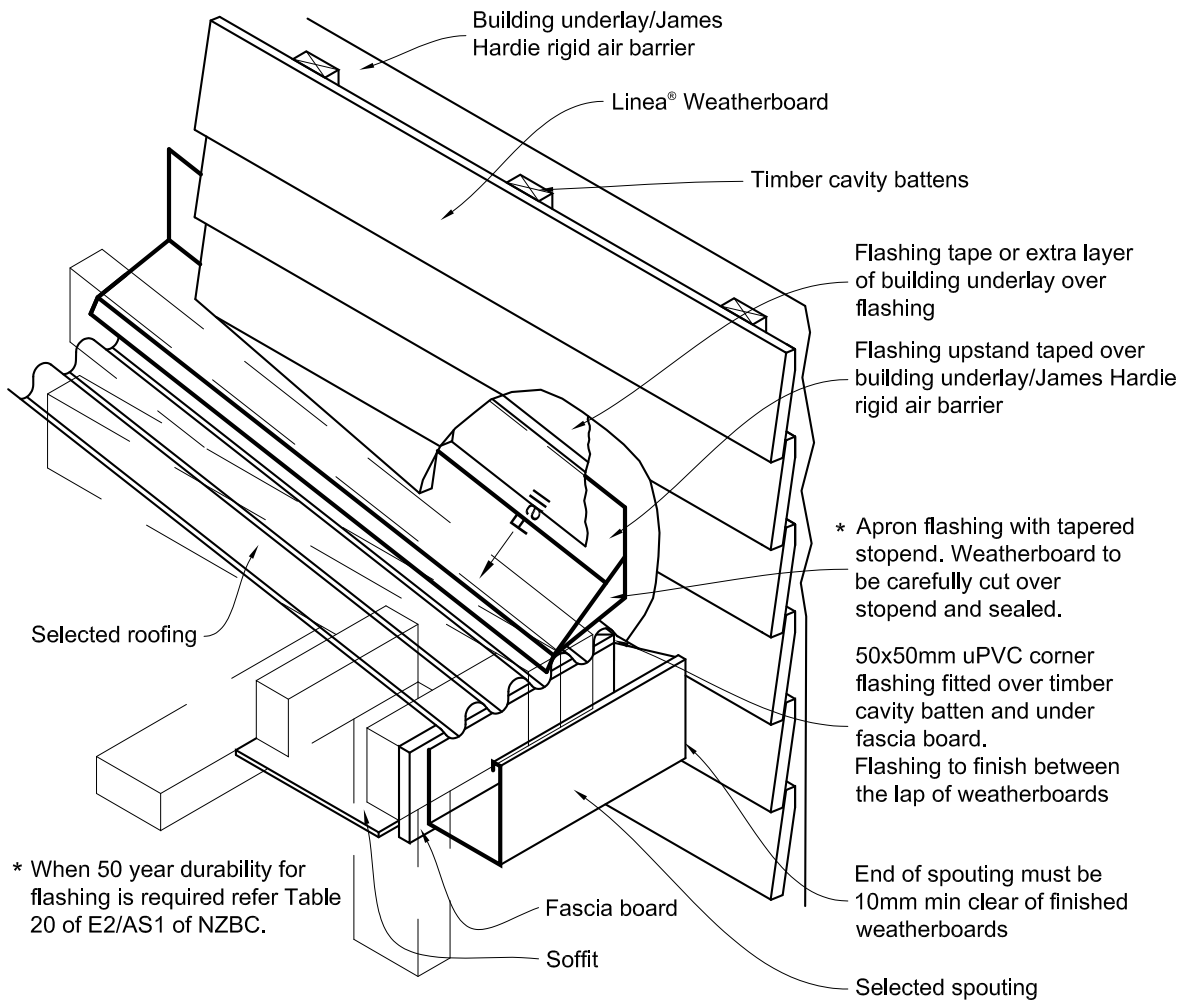

Figure 47: Timber cavity pipe penetration

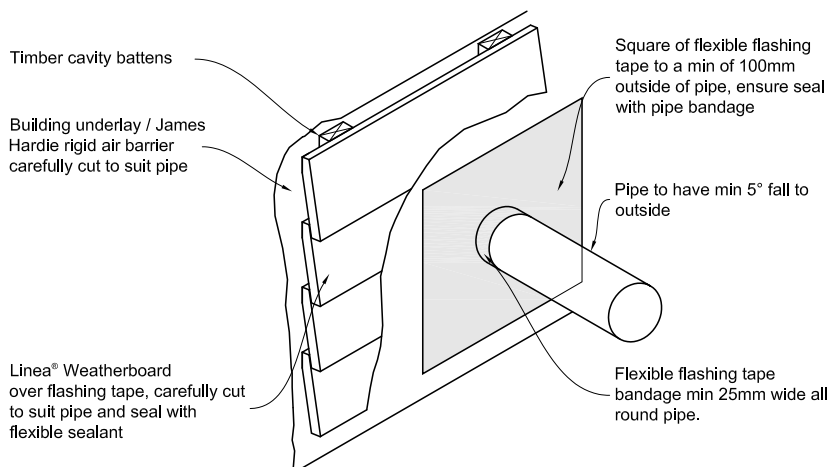

Figure 48: Timber cavity meter box at head

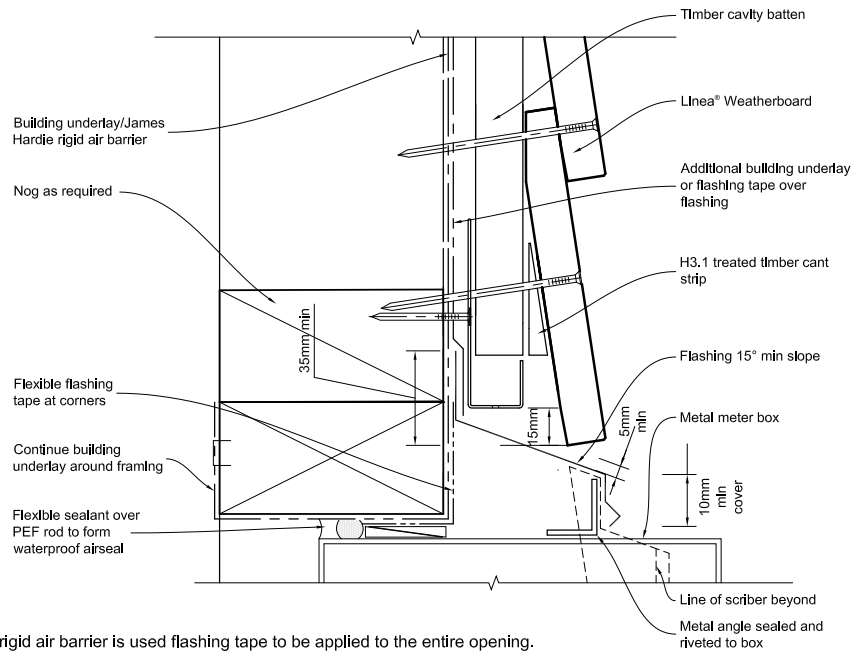

Figure 49: Timber cavity meter box at sill

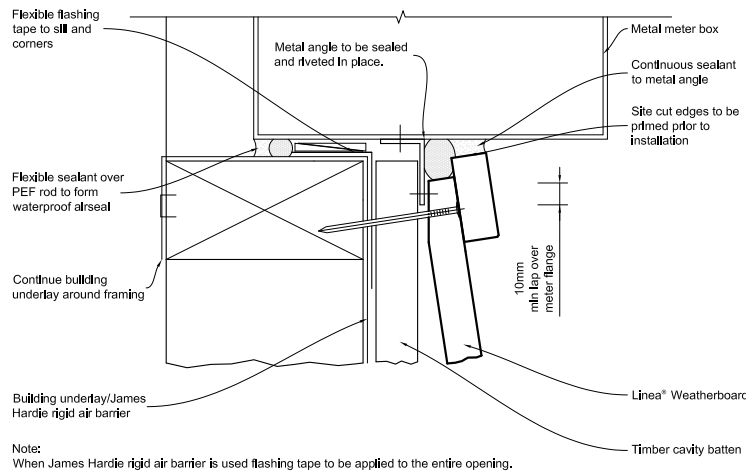

Figure 50: Timber cavity meter box at jamb

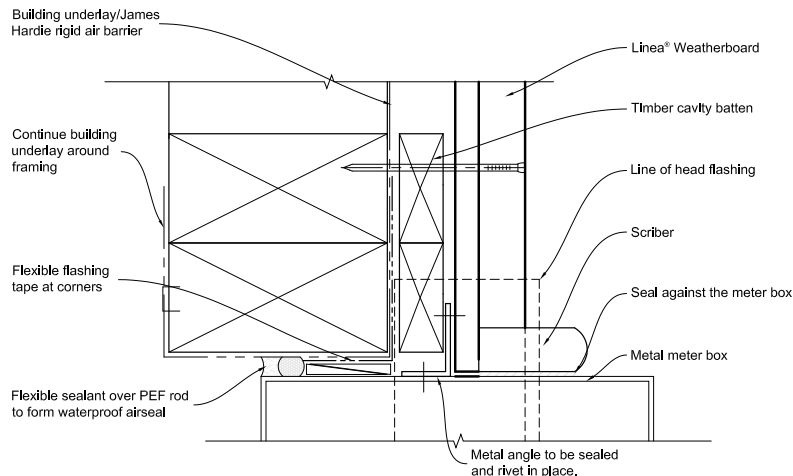

Figure 51: Timber cavity fix meter box

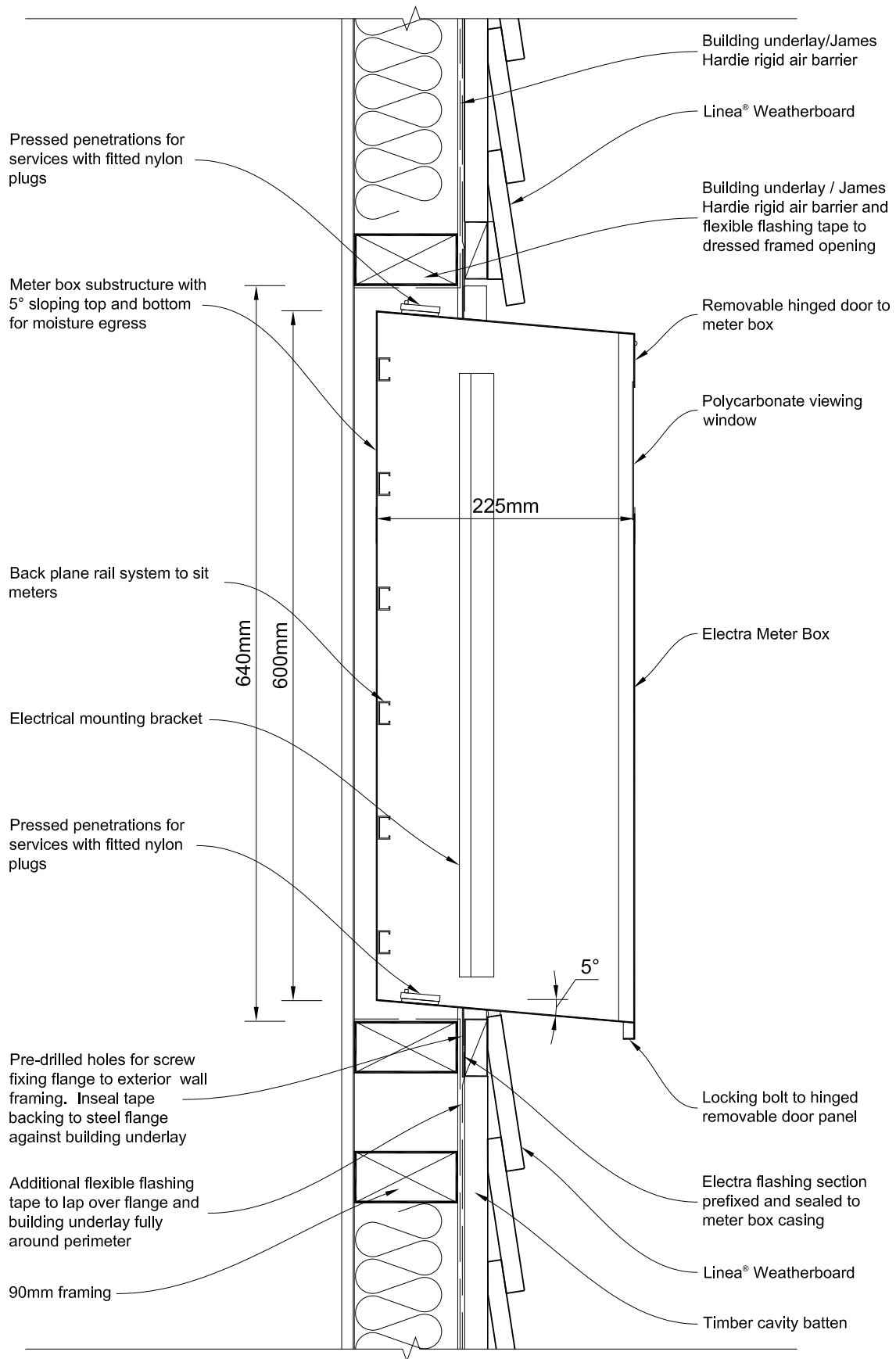

Figure 52: Timber cavity drainage joint

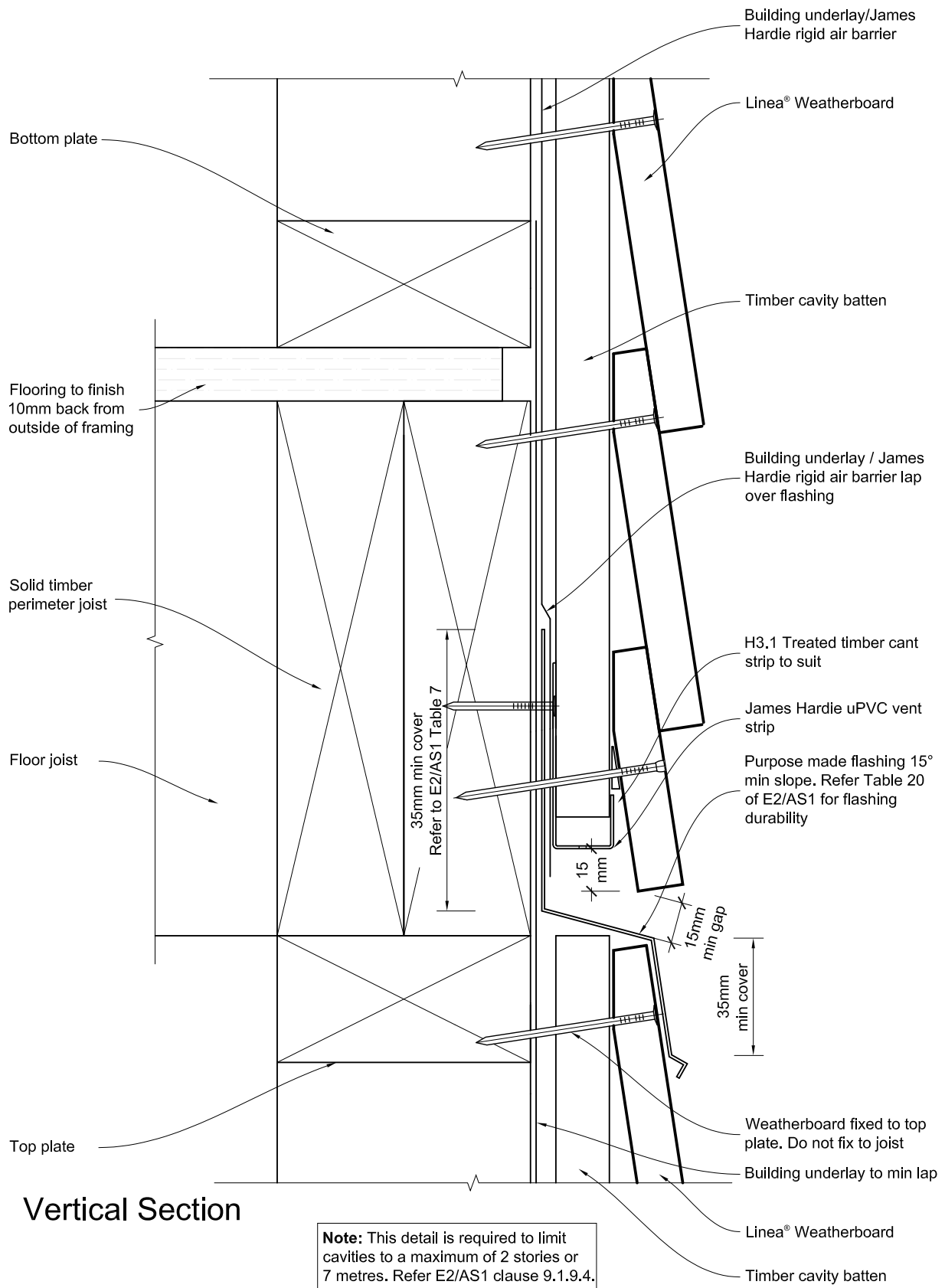

Figure 53: Timber cavity enclosed deck balustrade to wall

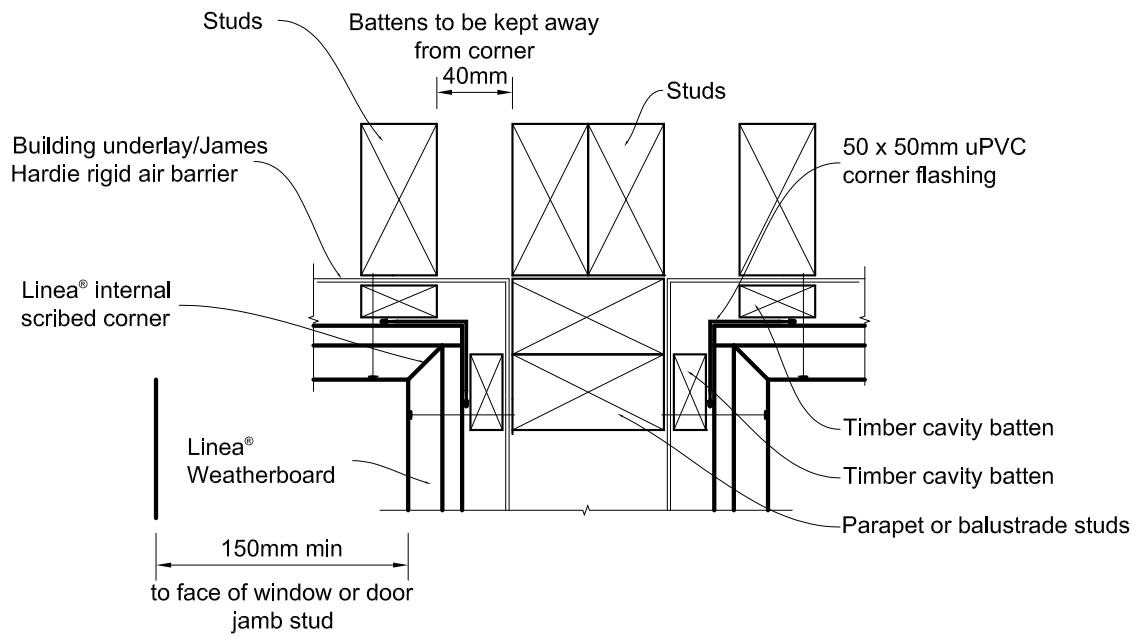

Figure 54: Timber cavity enclosed balustrade to wall

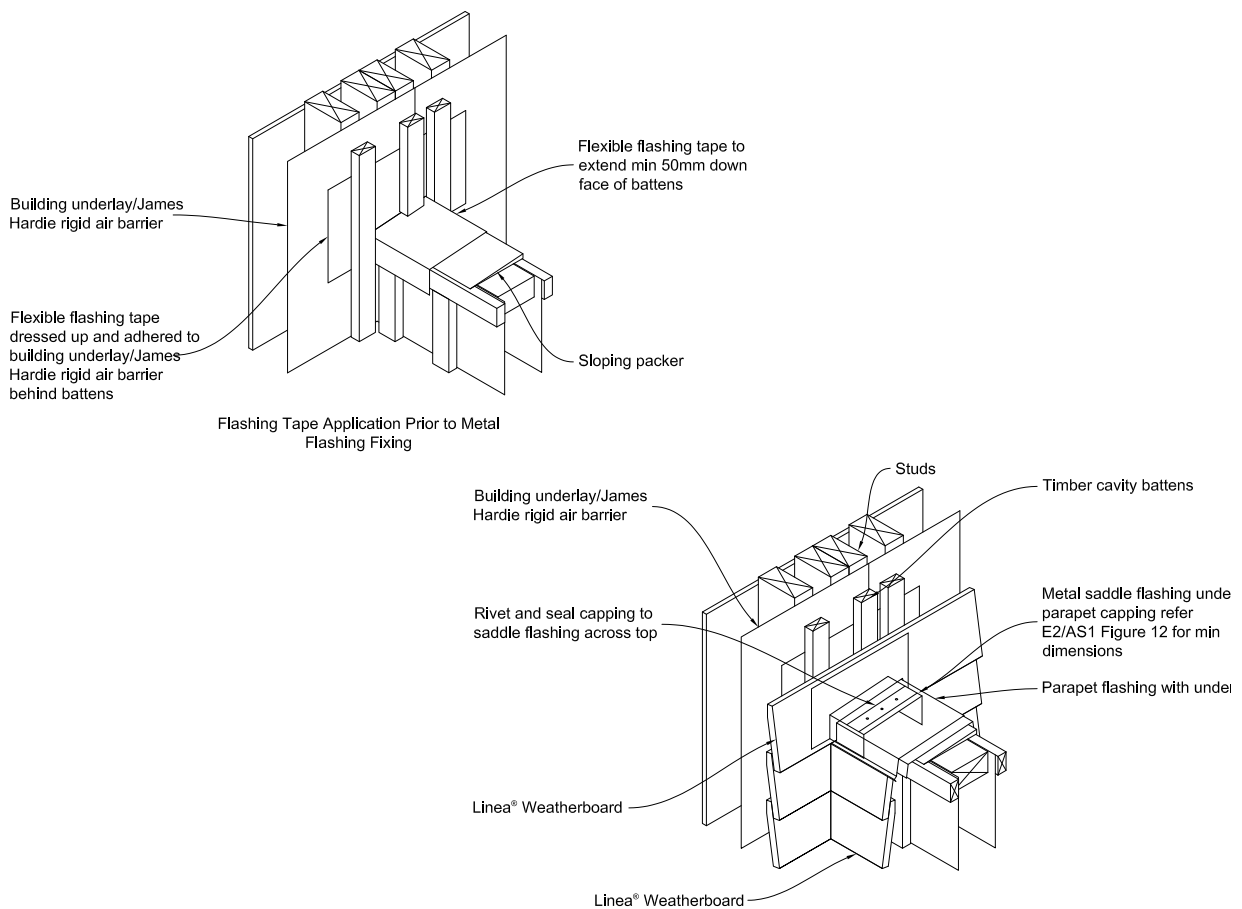
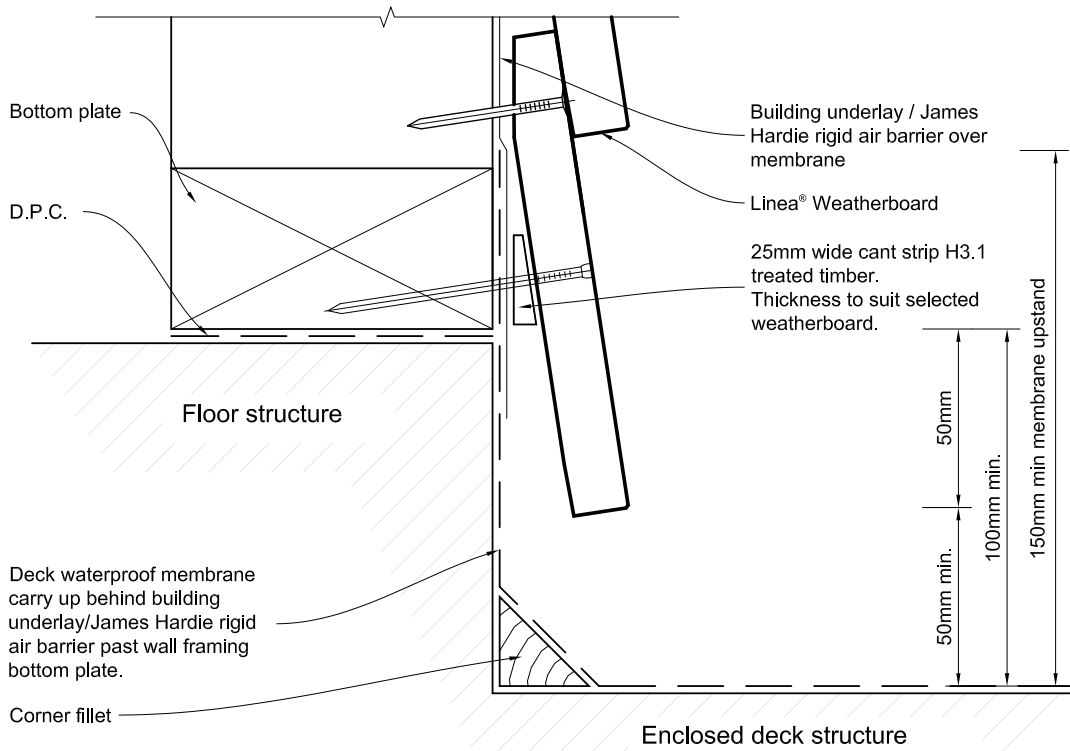
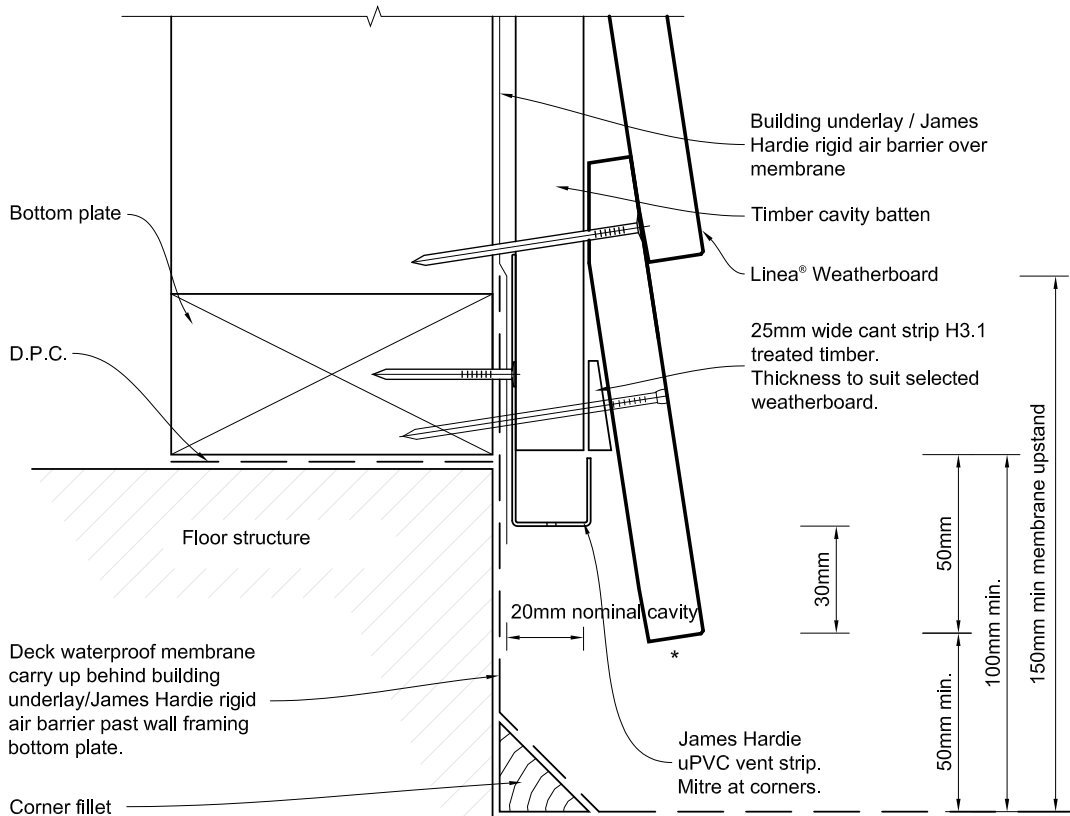

Figure 55: Direct fixed and timber cavity at enclosed deck



Direct Fixed Detail



Cavity Detail

* Drain holes in James Hardie uPVC vent strip are sufficient to achieve ventilation openings of 1000mm² per lineal metre

Figure 56: Timber cavity parapet flashing

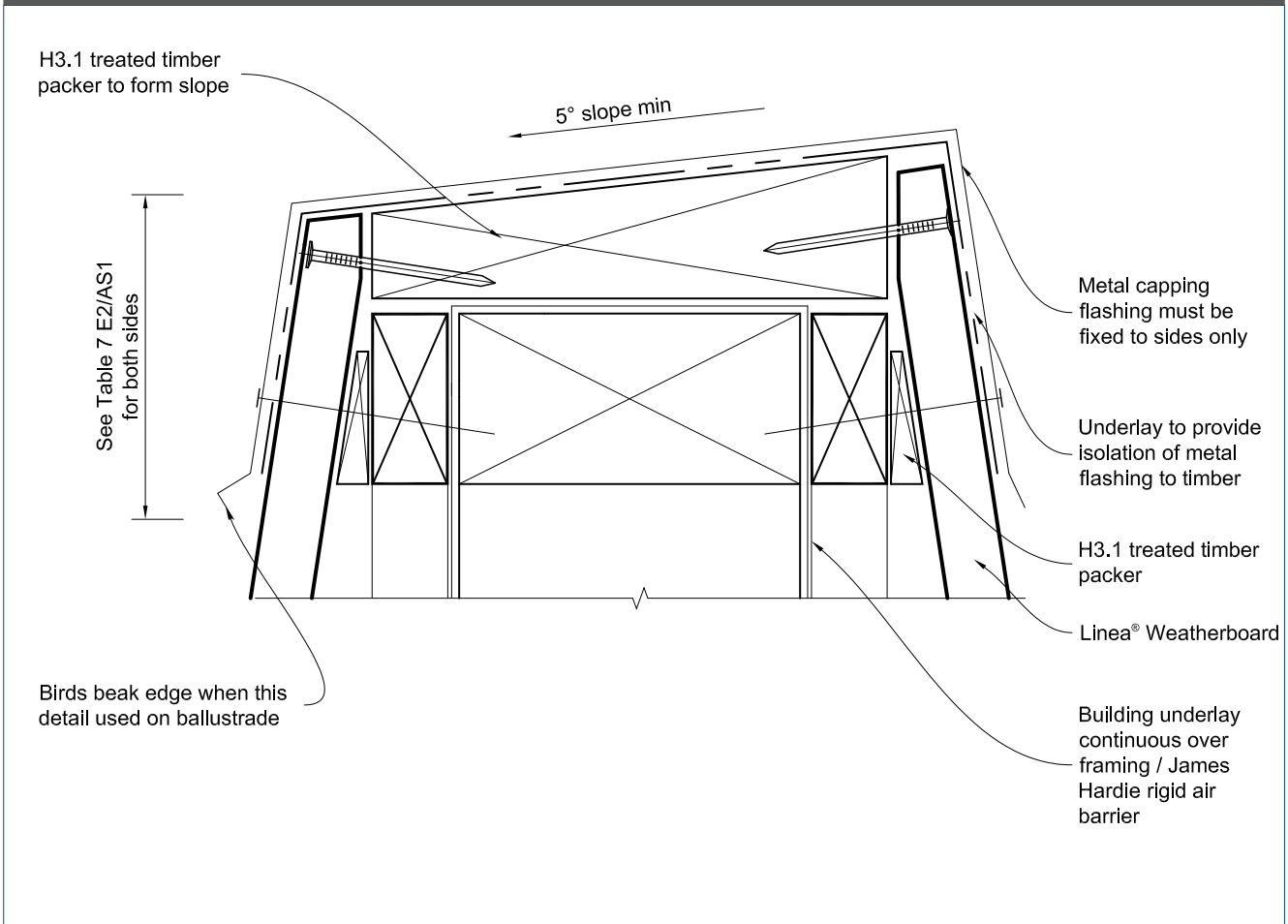

Figure 57: Sloping soffit to weatherboard junction

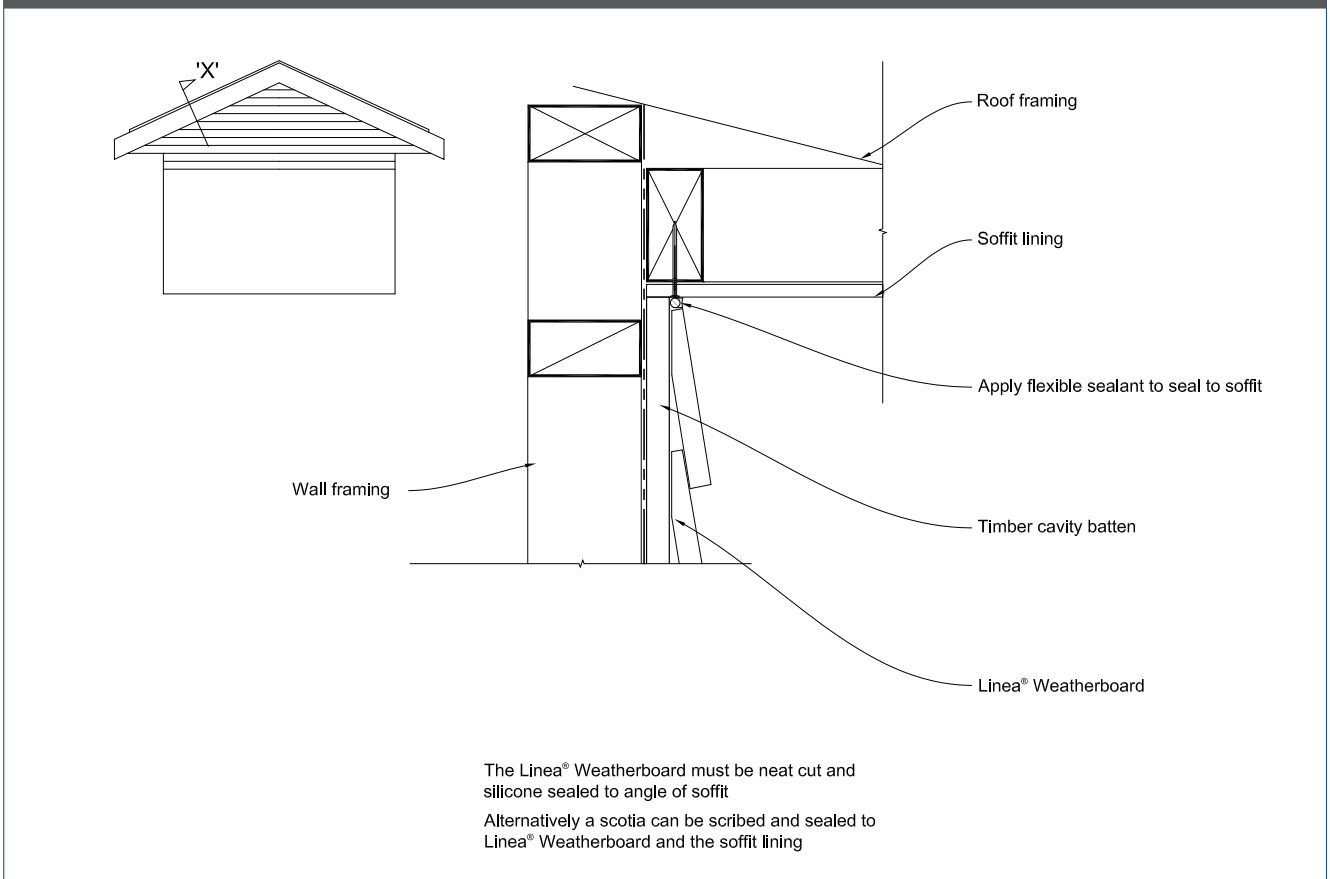

Figure 58: Timber cavity fix deck junction

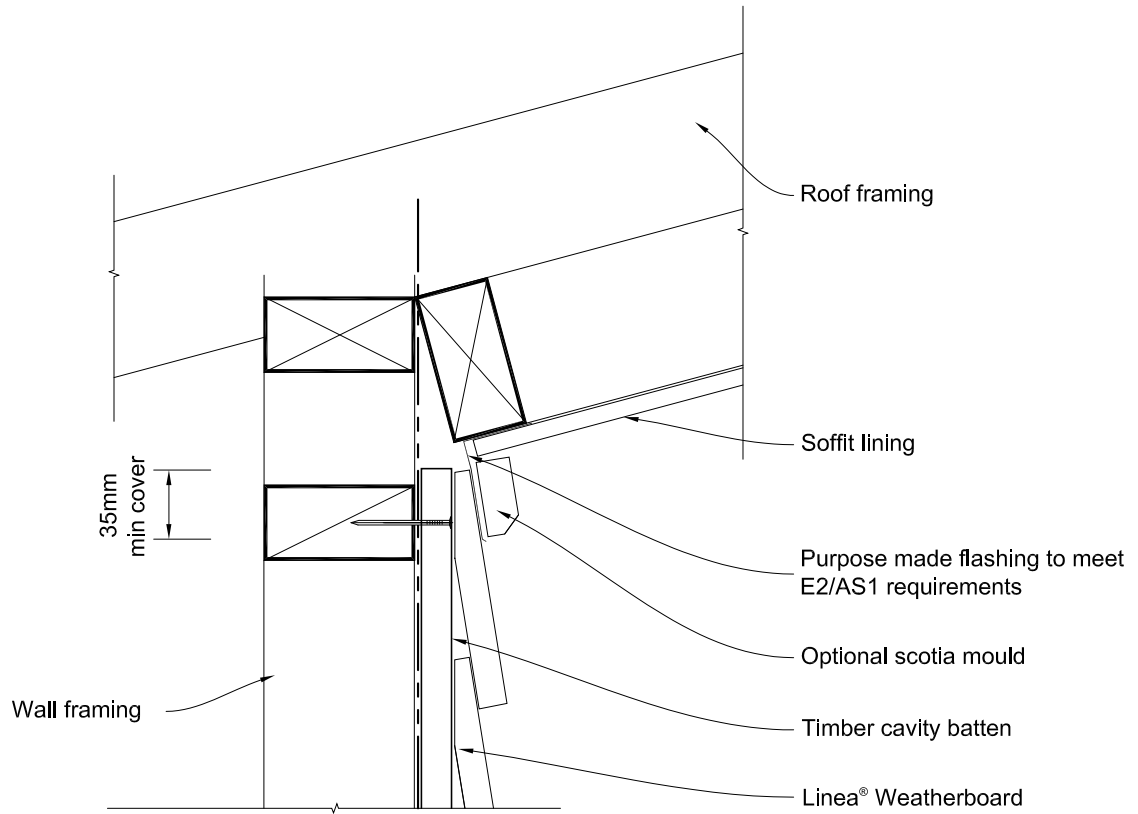

Figure 59: Timber cavity cantilevered timber deck junction

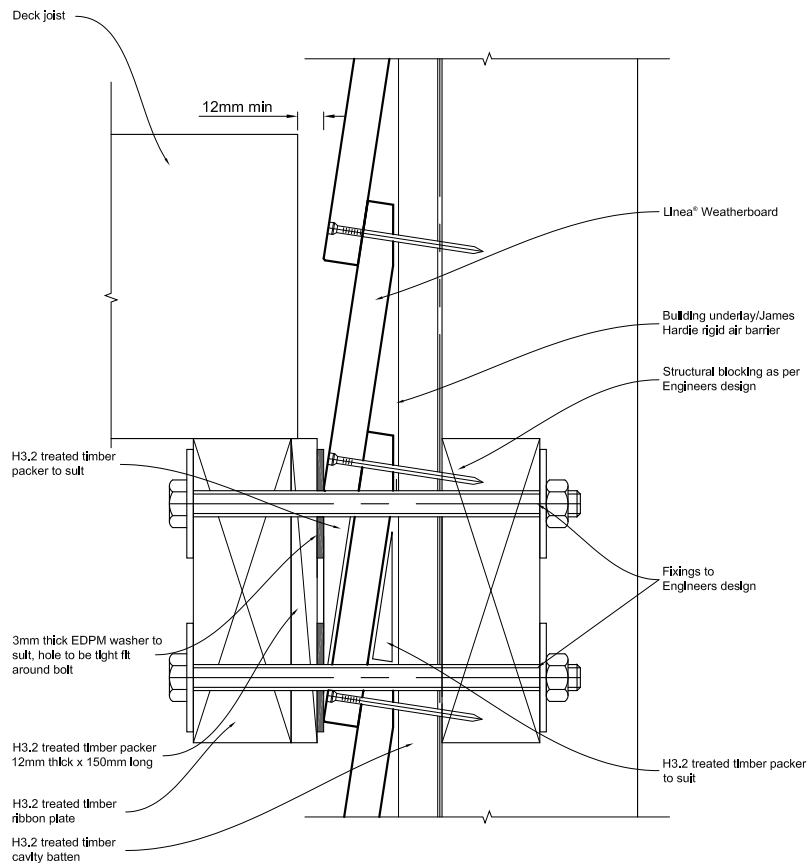

Figure 60: Timber deck junction

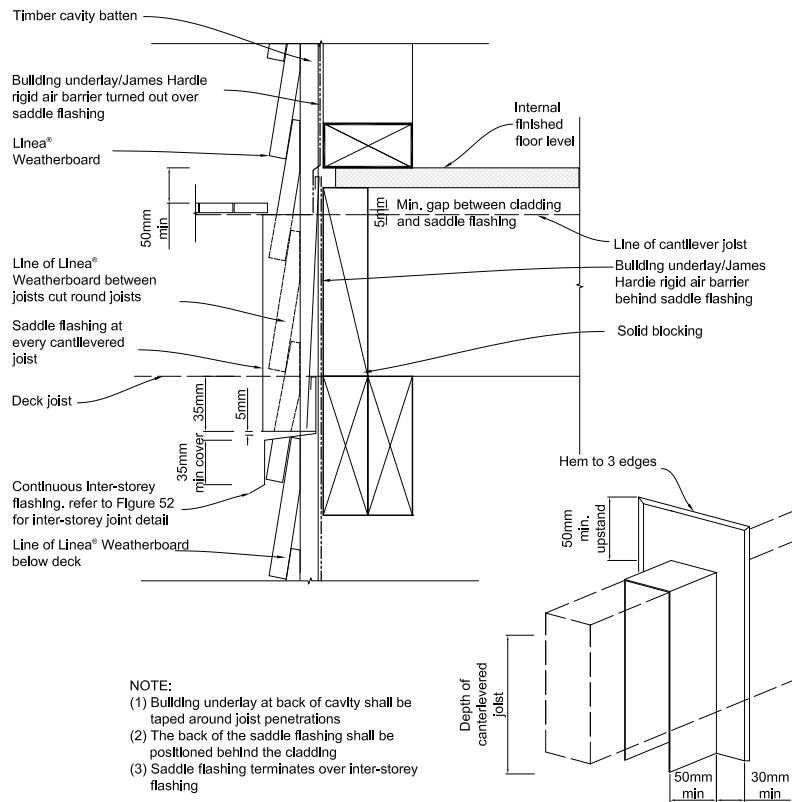
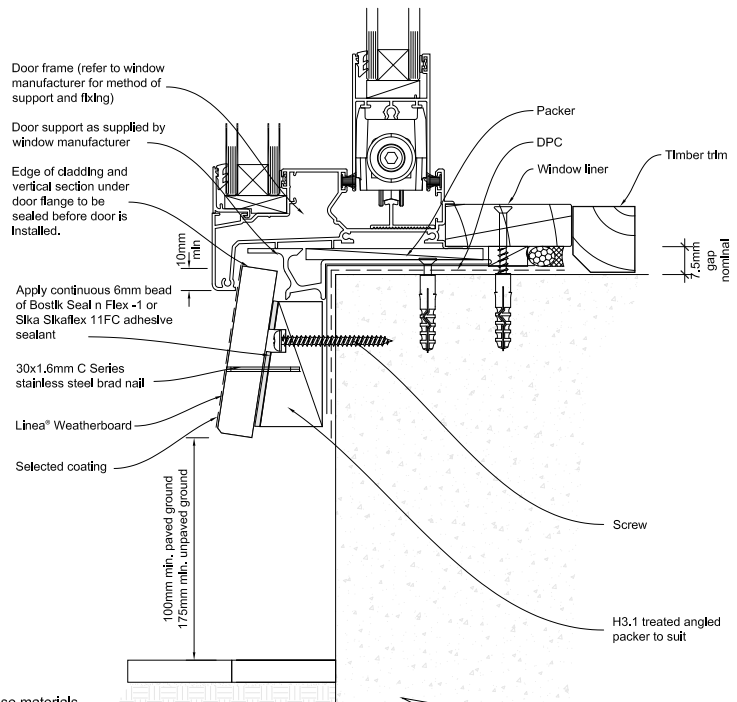

Figure 61: Door sill support detail



General notes for materials selection

1. Flashing materials must be selected based on environmental exposure, refer to NZS 3604 and Table 20 of the NZBC E2/AS1.
2. Building underlay must comply with acceptable solution E2/AS1 and NZS 3604.
3. Flashing tape must have proven compatibility with the selected building underlay and other materials with which it comes into contact as per Table 21 of E2/AS1.
4. Linea® Weatherboard to have sealed butt joint over batten at each corner of opening.

Figure 62: Junction between Linea® Weatherboard and fascia board

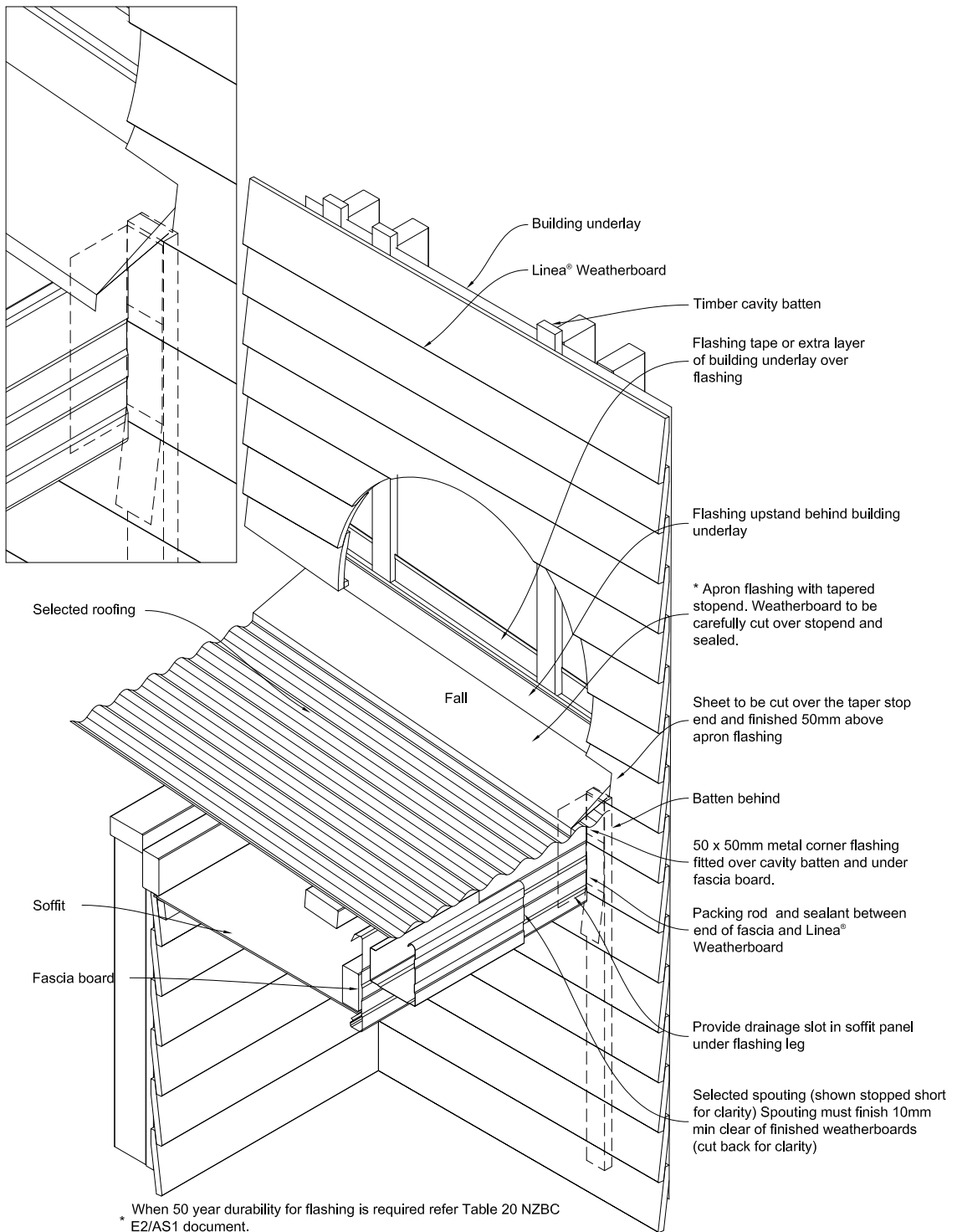
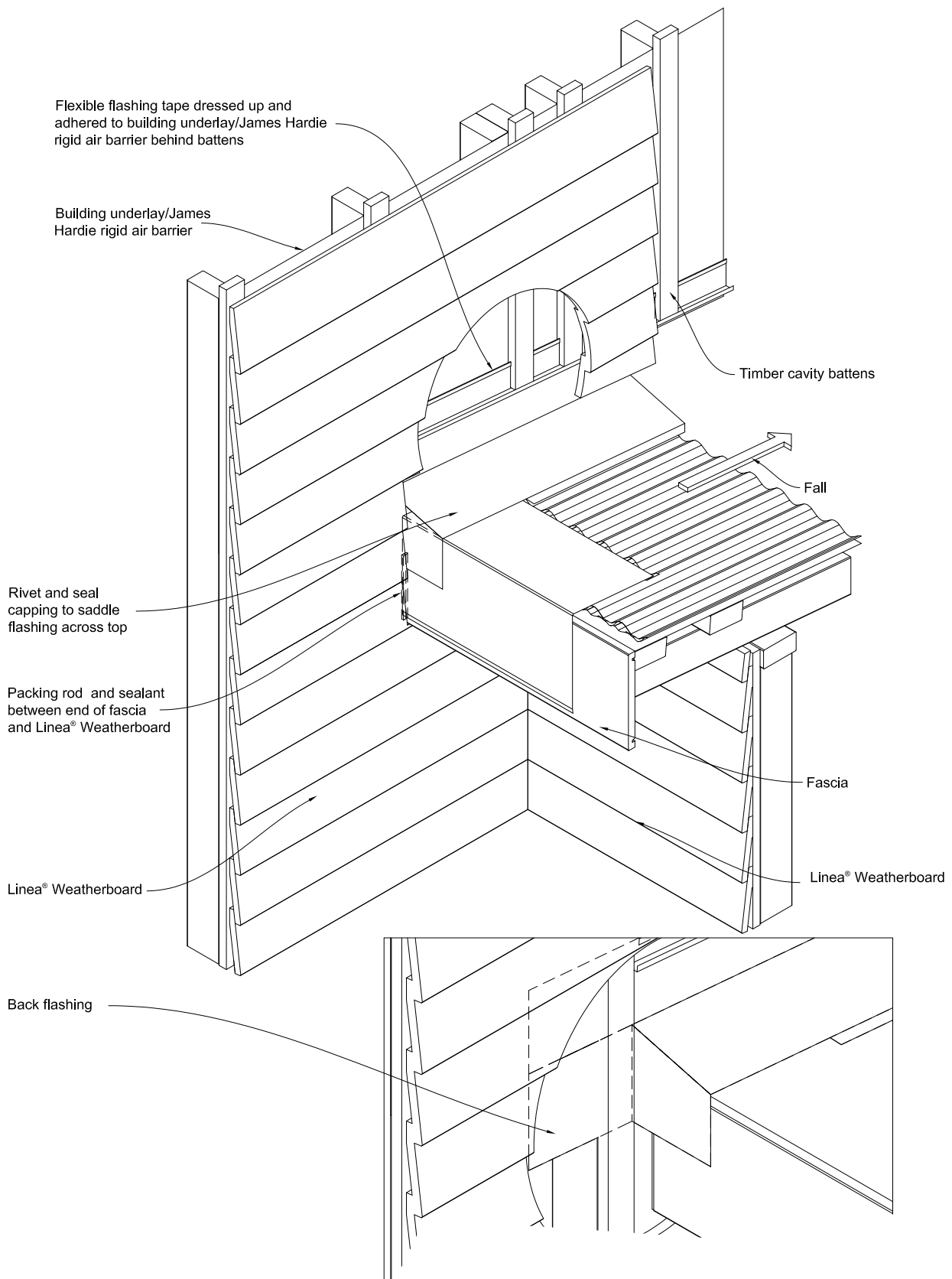

Figure 63: Enclosed roof to wall intersection



Product Warranty

Linea®
WEATHERBOARD

March 2015

Warranty: James Hardie New Zealand (“James Hardie”) warrants for a period of 25 years from the date of purchase that the Linea® Weath^{er}board (the “Product”), will be free from defects due to defective factory workmanship or materials and, subject to compliance with the conditions below, will be resistant to cracking, rotting, fire and damage from termite attacks to the extent set out in James Hardie’s relevant published literature current at the time of installation. James Hardie warrants for a period of 15 years from the date of purchase that the Axent™ Trim and accessories supplied by James Hardie will be free from defects due to defective factory workmanship or materials.

Nothing in this document shall exclude or modify any legal rights a customer may have under the Consumer Guarantees Act or otherwise which cannot be excluded or modified at law.

CONDITIONS OF WARRANTY:

The warranty is strictly subject to the following conditions:

- a) James Hardie will not be liable for breach of warranty unless the claimant provides proof of purchase and makes a written claim either within 30 days after the defect would have become reasonably apparent or, if the defect was reasonably apparent prior to installation, then the claim must be made prior to installation.
- b) This warranty is not transferable.
- c) The Product must be installed and maintained strictly in accordance with the relevant James Hardie literature current at the time of installation and must be installed in conjunction with the components or products specified in the literature. Further, all other products, including coating and jointing systems, applied to or used in conjunction with the Product must be applied or installed and maintained strictly in accordance with the relevant manufacturer’s instructions and good trade practice.
- d) The project must be designed and constructed in strict compliance with all relevant provisions of the current New Zealand Building Code (“NZBC”), regulations and standards.
- e) The claimant’s sole remedy for breach of warranty is (at James Hardie’s option) that James Hardie will either supply replacement product, rectify the affected product or pay for the cost of the replacement or rectification of the affected product.
- f) James Hardie will not be liable for any losses or damages (whether direct or indirect) including property damage or personal injury, consequential loss, economic loss or loss of profits, arising in contract or negligence or howsoever arising. Without limiting the foregoing James Hardie will not be liable for any claims, damages or defects arising from or in any way attributable to poor workmanship, poor design or detailing, settlement or structural movement and/or movement of materials to which the Product is attached, incorrect design of the structure, acts of God including but not limited to earthquakes, cyclones, floods or other severe weather conditions or unusual climatic conditions, efflorescence or performance of paint/coatings applied to the Product, normal wear and tear, growth of mould, mildew, fungi, bacteria, or any organism on any Product surface or Product (whether on the exposed or unexposed surfaces).
- g) All warranties, conditions, liabilities and obligations other than those specified in this warranty are excluded to the fullest extent allowed by law.
- h) If meeting a claim under this warranty involves re-coating of Products, there may be slight colour differences between the original and replacement Products due to the effects of weathering and variations in materials over time.

Disclaimer: The recommendations in James Hardie’s literature are based on good building practice, but are not an exhaustive statement of all relevant information and are subject to conditions (c), (d), (f) and (g) above. James Hardie has tested the performance of Linea® Weath^{er}board when installed in accordance with the Linea® Weath^{er}board technical specification, in accordance with the standards and verification methods required by the NZBC and those test results demonstrate the product complies with the performance criteria established by the NZBC. However, as the successful performance of the relevant system depends on numerous factors outside the control of James Hardie (e.g. quality of workmanship and design) James Hardie shall not be liable for the recommendations made in its literature and the performance of the relevant system, including its suitability for any purpose or ability to satisfy the relevant provisions of the NZBC, regulations and standards, as it is the responsibility of the building designer to ensure that the details and recommendations provided in the relevant James Hardie installation manual are suitable for the intended project and that specific design is conducted where appropriate.

Copyright March 2015. © James Hardie New Zealand. TM and ® denotes a Trademark or Registered Mark owned by James Hardie Technology Limited.

Ask James Hardie™
Call 0800 808 868
www.jameshardie.co.nz





James Hardie
a smarter way™



Ask James Hardie™ | Call 0800 808 868 | jameshardie.co.nz

Copyright March 2015. © James Hardie New Zealand. TM and ® denotes a Trademark or Registered Mark owned by James Hardie Technology Limited.