

James Hardie®

EAVES AND SOFFITS

Installation Manual

FEBRUARY 2013 | NEW ZEALAND



James Hardie
a smarter way™

Content

1	INTRODUCTION	3	5	JOINTING OPTIONS	19
	Eclipsa™ Eaves Lining	3			
	Silkline® Soffit Lining	3	6	JOINTING AND FINISHING	21
	HardieGroove™ Soffit Lining	3	6.1	General	21
	Villaboard® Soffit Lining	3	6.2	Glancing Light	21
	Hardiesoffit™ Lining	4	6.3	Level of Finishes	21
	HardieFlex™ Eaves Lining	4	6.4	Paint Finishes	22
	Product Description	5	6.5	Villaboard Soffit Lining Jointing and Stopping	22
	Accessories	6		Mixing Instructions	22
			6.6	Set Joints	23
2	SAFE WORKING PRACTICES	10	6.7	Painting	24
3	FRAMING	11	7	PRODUCT INFORMATION	25
3.1	Timber Frame	11	7.1	General	25
3.2	Steel Frame	11	7.2	Durability	25
3.3	Framing Set-Out	11	7.3	Finishes	25
3.4	Batten Requirements	12	8	MAINTENANCE	25
3.5	Skillion Roof Design	12		PRODUCT WARRANTIES	27
4	INSTALLATION	12			
4.1	General	13			
4.2	Fastener Durability	13			
4.3	Hardiesoffit Lining	14			
4.4	HardieFlex Eaves Lining	14			
4.5	HardieGroove Soffit Lining Fixing Method	14			
4.6	Eclipsa Eaves Lining and Silkline Soffit Lining	15			
4.7	Villaboard Soffit Lining (small soffits)	15			
4.8	Titan® Facade Panel in a Soffit Application	18			
4.9	Internal Swimming Pool Application	18			
4.10	Special Details	19			

WE VALUE YOUR FEEDBACK

To continue with the development of our products and systems, we value your input. Please send any suggestions, including your name, contact details, and relevant sketches to:

Ask James Hardie™

Fax 0800 808 988

literaturefeedback@jameshardie.co.nz

1 Introduction

James Hardie have a wide range of soffit linings and pre-finished soffit linings that enable you to create the look you want.

Cool, wide soffits and verandahs have, over the years, been a feature which specifiers have used to provide shade from the hot summer sun and to give UV protection to exterior paintwork and interior fabrics.

Today's high energy costs demand that all avenues be explored to develop cost-efficient ways for keeping our homes cool. One

of these methods — tried and proven — is the use of wide soffits, verandahs and covered outdoor living areas. James Hardie products are resistant to fire and damage from moisture and rotting when installed and maintained as directed.

James Hardie Eclipsa Eaves Lining, HardieGroove Soffit Lining, Silcline Soffit Lining, HardieFlex Eaves Lining, Hardiesoffit Lining and Villaboard Soffit Lining are not suitable for use as a cladding.



Eclipsa™
EAVES LINING

Eclipsa™ Eaves Lining is a 4.5mm thick, pre-finished acrylic eave providing innovative style and enduring performance.

- Easy to install, saving both time and money.
- A slipsheet minimises surface marks on paint during transportation and installation.

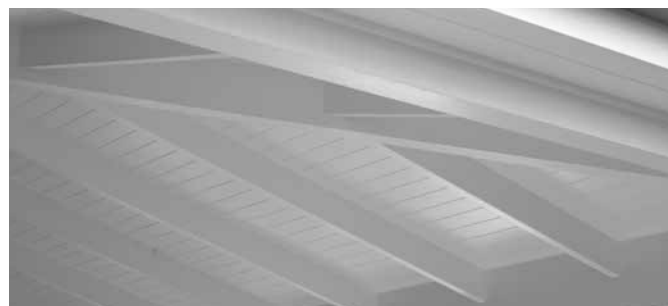

HardieGroove™
SOFFIT LINING

HardieGroove™ Soffit Lining has the charm of traditional tongue and groove timber panelling, but has all the qualities of a modern James Hardie fibre cement product. It's perfect for enhancing design lines on modern buildings or renovating old villas and bungalows.

- HardieGroove Soffit Lining comes with a half groove length ways along the edge of the sheet to achieve concealed joints.

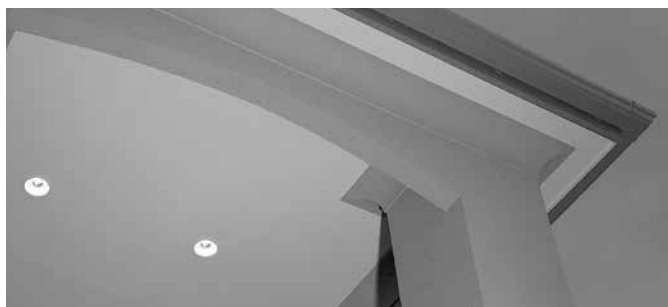

Silcline®
SOFFIT LINING

Pre-finished Silcline® Soffit Linings are 4.5mm in thickness and comes as a complete, easy-to-install soffit lining with jointers, cappings, Fastfix fasteners and a simple two-piece scotia to complete a good-looking soffit.

- Silcline Soffit Lining is the ideal lining for soffits, eaves, verandahs, carports and porches or wherever a decorative easy-clean ceiling lining is required, e.g. spa pools, kitchens and garages.
- When low maintenance building materials are your choice, Silcline Soffit Linings will last and meet these needs. In addition, they have a 10 year coating warranty to give you extra peace of mind.



Villaboard®
SOFFIT LINING

Villaboard® Soffit Linings are 6mm and 9mm in thickness to suit both residential and commercial applications. The recessed edges are suitable for flush jointing to give a smooth flush finish. Ideal for larger sized soffits.

- The sheets are fully sanded to give a smoother face surface.
- Two long sheet edges are supplied with a recessed finish and site-cut edges can be readily ground on site. Other combinations are also available. Refer Table 3, page 5.
- Square-edge sheets are also available. These sheets can be used for the alternative expressed, sealant-filled or uPVC joint finish.



Hardiesoffit™ LINING

Hardiesoffit™ Linings are 4.5mm thick and are specifically manufactured for the narrow soffit around the perimeter of the house or building. Standard widths of 450mm, 600mm and 750mm are available.

- Hardiesoffit Linings have an unsanded finish suitable for semi-gloss acrylics or lightly textured semi-gloss or high-gloss coatings. Smooth high-gloss coatings must be avoided as some surface undulations may be visible in critical light.
- Hardiesoffit Linings can be nail-fixed to timber or mechanically fixed to a steel frame.
- Hardiesoffit Linings can be uPVC jointed or the joints can be left expressed.



HardieFlex™ EAVES LINING

HardieFlex™ Eaves Lining are 4.5mm in thickness and are available in wider widths for use in wider soffits, ceilings and verandahs. They are complementary to the Hardiesoffit Lining and are fixed and jointed in a similar way.

- HardieFlex Eaves Lining has an unsanded finish suitable for semi-gloss acrylics or lightly textured coatings. Smooth high-gloss coatings must be avoided as some surface undulations may be visible in critical light.
- HardieFlex Sheet 6mm, can also be used in eaves application for extra rigidity on larger spanning eaves.
- When higher impact or wind resistance is required, 6mm thick HardieFlex Sheet is used.



This manual covers the use of Eclipsa Eaves Lining, Silkline Soffit Lining, Villaboard Soffit Lining, HardieGroove Soffit Lining, Hardiesoffit Lining and HardieFlex Eaves Lining in external eave and soffit applications. Further technical literature relating to these products and internal linings are available from James Hardie in the following manuals:

- Villaboard Lining Installation Manual.
- HardieGroove Lining Installation Manual.
- Fire and Acoustic Design Manual.

The specifier or other responsible party for the project must ensure the information and details in this manual are appropriate for the intended application and specific design and detailing is undertaken for areas which fall outside the scope of this document.

MAKE SURE YOUR INFORMATION IS UP TO DATE

When specifying or installing James Hardie products, ensure you have the current manual. If you're not sure you do, or you need more information, visit www.jameshardie.co.nz or Ask James Hardie™ on 0800 808 868.

PRODUCT DESCRIPTION

Table 1

Eclipsa Eaves Lining Sheet Sizes						
Pre-finished square-cut edge sheet for use with jointers		Length	Mass (kg/m ²)	Width (mm)		
				600	1200	
		4.5mm thickness	5.9			
		2400		✓	✓	

Table 2

Silkline Soffit Lining Sheet Sizes						
Pre-finished square-cut edge sheet for use with jointers.		Length	Mass (kg/m ²)	Width (mm)		
				600	1200	
		4.5mm thickness	5.9			
		2400		✓	✓	

Table 3

Villaboard Soffit Lining Sheet Sizes						
Smooth recessed edge for flush jointing. Square-cut edge also available for use with jointers. 6mm Villaboard Lining has no chamfer on square edge sheet. 9mm Villaboard Lining has small chamfer on square edge sheet.		Length	Mass (kg/m ²)	Width (mm)		
				1200		
				4 rec/edges	2 rec/edges (long)	Square edges
		6mm thickness	8.3			
		2400		✓	✓	✓
		2700			✓	
		3000			✓	✓
		9mm thickness	12.4			
		2400		✓	✓	✓
		2700			✓	
3000			✓	✓		

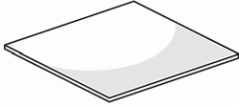
Table 4

HardieGroove Soffit Lining Sheet Sizes					
Half groove length ways to achieve concealed joints. 	Length	Mass (kg/m ²)	Width (mm)		
			1200		
	7.5mm thickness	10.44			
	2400			✓	
2700			✓		

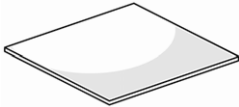
Table 5

Hardiesoffit Lining Sheet Sizes						
Square-cut edge sheet for use with jointers.		Length	Mass (kg/m ²)	Width (mm)		
				450	600	750
		4.5mm thickness	5.9			
		2400		✓	✓	✓

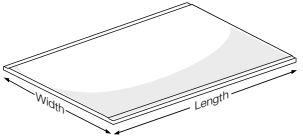
Table 6

HardieFlex Eaves Lining Sheet Sizes							
Square-cut edge sheet for use with jointers.		Length	Mass (kg/m ²)	Width (mm)			
				1800	2400	2700	3000
		4.5mm thickness	5.9				
		900			✓		
		1200		✓	✓	✓	✓
		6mm thickness	7.8				
1200			✓	✓	✓		

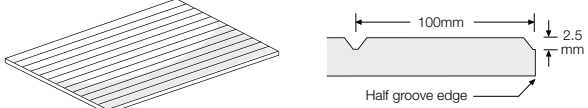
ACCESSORIES

Table 7

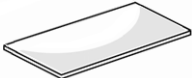
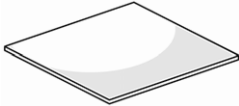



Eclipsa Eaves Lining And Silkline Soffit Lining – Accessories / Tools Supplied by James Hardie					
Accessories	Description	Product Code	Accessories	Description	Product Code
	Hardiejointer™ 5mm 2400 long 750 long 600 long 450 long	300729 300921 300920 300919		Silkline PVC 2-way Jointer 2400 long, uPVC / White	300915
	Silkline Scotia Mould (base and cap) 2400 long, uPVC / White	300916		HardieFlex Capping Mould 5mm 2400 long, uPVC / White	300538
	Fastfix Fasteners 38 x 12mm, Nylon / White	300632		Inseal 3259 1.5mm thick 50mm wide x 50m long, Black compressible foam	300767
	Eclipsa Eaves Lining and Silkline Soffit Lining Touch-up Paint 15ml	Free Ask James Hardie on 0800 808 868			

Table 8



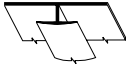

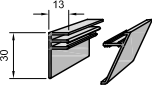
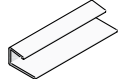
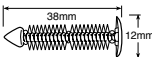

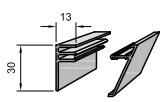

Villaboard® Soffit Lining — Accessories / Tools Supplied by James Hardie					
Accessories	Description	Product Code	Accessories	Description	Product Code
	Silkline Scotia Mould (base and cap) 2400 long, uPVC / White	300916		Inseal 3259 1.5mm thick 50mm wide x 50m long, Black compressible foam	300767
	Hardiejointer 6mm uPVC / Bone colour 2400 long 3000 long	300730 300734		9mm Hardiejointer uPVC / Bone colour 3000mm long	300736
	HardieFlex Capping Mould 6mm 2400 long 3000 long uPVC / Bone colour	300539 300540		Control Joint 2700 long, uPVC / White	300978
	Corner Angle 3000 long uPVC	300669		James Hardie Top Coat Topping compound for flush finished jointing.	3kg Pail 304492 15kg Pail 304493
	James Hardie Base Coat Base compound for flush finished jointing.	4kg Pail 304490 15kg Bag 304491		HardieBlade Saw Blade Ø185mm poly crystalline diamond blade, for fast, clean cutting of James Hardie fibre cement.	300660
	HardieDrive Screw s/s 316 30mm x 7g 100 per jar For fastening to timber frames.	300928		Villadrive Screw 6g x 30mm For fastening to timber frames. 100/jar 5kg Collated/1000	300992 300993 300994
	FibreZip® Screws Self drilling rib head screw Box 1000	303840			

Table 9

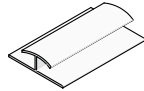

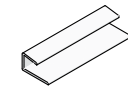
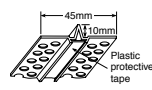
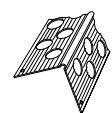

HardieGroove Soffit Lining — Accessories / Tools Supplied by James Hardie					
Accessories	Description	Product Code	Accessories	Description	Product Code
	Silkline Scotia Mould (base and cap) 2400 long, uPVC / white	300916		Inseal 3259 1.5mm thick 50mm wide x 50m long, black compressible foam	300767
	HardieBlade Saw Blade Ø185mm poly crystalline diamond blade, for fast, clean cutting of James Hardie fibre cement.	300660		James Hardie Top Coat Topping compound for flush finished jointing.	3kg Pail 304492 15kg Pail 304493
	HardieDrive Screw s/s 316 30mm x 7g. 100 per jar For fastening to timber frames.	300928		Villadrive Screw 6g x 30mm For fastening to timber frames. 100/jar 5kg Collated/ 1000	300992 300993 300994

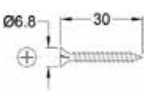
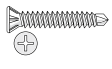
Table 10



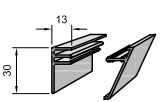



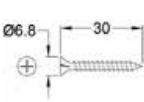



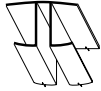
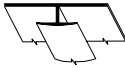
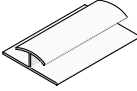
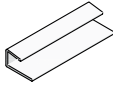
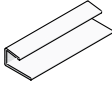
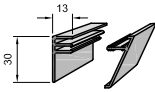
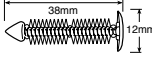



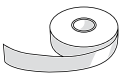

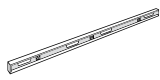

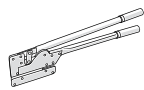
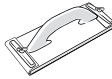

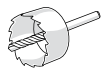
HardieFlex™ Eaves Lining And Hardiesoffit™ Lining — Accessories / Tools Supplied by James Hardie					
Accessories	Description	Product Code	Accessories	Description	Product Code
	Silkline PVC 2-way Joints 2400 long, uPVC / White	300915		Hardiejointer 5mm uPVC / White 2400 long 750 long 600 long 450 long	300729 300921 300920 300919
	6mm Hardiejointer uPVC/Bone colour 2400 long 3000 long	300730 300734		HardieFlex 5mm Capping Mould 2400 long, uPVC / White	300538
	6mm Capping Mould uPVC/Bone colour 2400 long 3000 long	300539 300540		Scotia Mould (base and cap) 2400 long, uPVC / White	300916
	Fastfix Fasteners 38 x 12mm, Nylon / White	300632		Inseal 3259 1.5mm thick 50mm wide x 50m long, Black compressible foam	300767

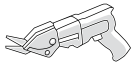
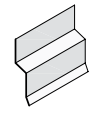
Table 11

Components Not Supplied by James Hardie			
James Hardie recommends the following products for use in conjunction with its eaves and soffit linings. James Hardie does not supply these products. Please contact component manufacturer for information on their warranties and further information on their products.			
Accessories	Description	Accessories	Description
	HardieFlex Nail 40 x 2.8mm galvanised or stainless steel nails.		Second Coat Trowel 200mm For installing second coats on set joints on Villaboard Lining.
	Rondo P35 Control joint used in movement joints.		Finishing Coat Trowel For installing top coats on set joints on Villaboard Lining.
	Perforated Paper Tape Joint reinforcing tape.		Corner Tool For setting of internal corners on Villaboard Lining.
	Level/straight Edge For checking straightness of frame.		Hawk To assist in the application of finishing compounds especially with the use of trowels.
	Hand Guillotine Guillotine for cutting fibre cement.		Hand Sander For sanding set joints on Villaboard Lining.
	Collated Screw Gun		Notched Trowel For applying tile adhesive to face of Villaboard Lining.
	Hole Saw		Broadknife 150mm For setting of joints on Villaboard Lining.
	Electric shear/Fibreshear For cutting Villaboard Soffit Lining, HardieGroove Soffit Lining, Hardiesoffit Lining, HardieFlex Eaves Lining.		Flashing to Table 20 'E2/AS1' Flashing fabricator
	Flashing Tape Proprietary tape to adhere to building wrap. Tyvek, Protecto wrap or similar		Flexible Joint Sealant Tube Sikaflex MS or similar
	Masking Tape 3M Scotch™ Blue painters tape 2090 or Sellotape 5855 Long Life		Paperback Corners 'Goldline' corner moulds
	Polyurethane Tape		Adhesive Sealant Sikaflex-11FC by Sika Seal N Flex-1 by Bostik
	Acrylic Paint Dulux X10 or similar brand		Waterproofing Admixture Multiplast Resin by Plaster Systems. Used in diluted form over Villaboard Lining sheet edges to control moisture suction before flush stopping.

2 Safe working practices

WARNING - DO NOT BREATHE DUST AND CUT ONLY IN WELL VENTILATED AREA

James Hardie products contain respirable crystalline silica which is considered by some international authorities to be a cause of cancer from some occupational sources. Breathing excessive amounts of respirable silica dust can also cause a disabling and potentially fatal lung disease called silicosis, and has been linked with other diseases. Some studies suggest smoking may increase these risks. During installation or handling: (1) work in outdoor areas with ample ventilation; (2) minimise dust when cutting by using either 'Score and Snap' knife, fibre cement shears or, where not feasible, use a HardieBlade™ Saw Blade and dust-reducing circular saw attached to a HEPA vacuum; (3) warn others in the immediate area to avoid breathing dust; (4) wear a properly-fitted, approved dust mask or respirator (e.g. P1 or P2) in accordance with applicable government regulations and manufacturer instructions to further limit respirable silica exposures. During clean-up, use HEPA vacuums or wet cleanup methods – never dry sweep. For further information, refer to our installation instructions and Safety Data Sheets available at www.jameshardie.co.nz.

FAILURE TO ADHERE TO OUR WARNINGS, SAFETY DATA SHEETS, AND INSTALLATION INSTRUCTIONS MAY LEAD TO SERIOUS PERSONAL INJURY OR DEATH.

James Hardie recommended safe working practices

CUTTING OUTDOORS

1. Position cutting station so that wind will blow dust away from user or others in working area.
2. Use one of the following methods based on the required cutting rate:

BEST

- Score and snap
- Hand guillotine
- Fibreshear

BETTER

- Dust reducing circular saw equipped with HardieBlade™ Saw Blade and HEPA vacuum extraction.

GOOD

- Dust reducing circular saw equipped with HardieBlade™ Saw Blade

CUTTING INDOORS

- Cut only using score and snap, hand guillotine or fibreshears (manual, electric or pneumatic).
- Position cutting station in well-ventilated area

SANDING/REBATING/DRILLING/OTHER MACHINING

When sanding/rebating/drilling/machining you should always wear a P1 or P2 dust mask and warn others in the immediate area.

IMPORTANT NOTES:

1. For maximum protection (lowest respirable dust production), James Hardie recommends always using "Best" — level cutting methods where feasible
2. NEVER use a power saw indoors
3. NEVER use a circular saw blade that does not carry the HardieBlade™ logo
4. NEVER dry sweep — Use wet suppression or HEPA Vacuum
5. NEVER use grinders
6. Always follow tool manufacturer's safety recommendations

P1 or P2 respirators can be used in conjunction with above cutting practices to further reduce dust exposures. Additional exposure information is available at www.jameshardie.co.nz to help you determine the most appropriate cutting method for your job requirements. If concern still exists about exposure levels or you do not comply with the above practices, you should always consult a qualified industrial hygienist or contact James Hardie for further information.

3 Framing

Working instructions

Refer to recommended Safe Working Practices before starting any cutting or machining of product.

Score and Snap

Score and Snap is a fast and efficient method of cutting the product using special tungsten tipped Score and Snap knife.



Preferably score on the face side of the product. Score against a straight edge and repeat the action to obtain adequate depth for clean break – normally 1/3 of sheet thickness. Snap upwards to achieve break. Smooth any rough edges with a rasp.

Hand Guillotine

Make guillotine cut on the off-cut side of line to allow for the thickness of the blade.

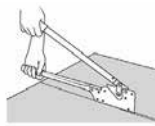

Fibreshear Heavy Duty

An electrically powered, fast, clean and effortless way of cutting James Hardie building products, especially around curves such as archways.

Make Fibreshear cut on the “off-cut” side of the line to allow for the thickness of the shear.



HardieBlade™ Saw Blade

The HardieBlade Saw Blade used with a dust-reducing and HEPA vacuum extraction allows for fast, clean cutting of James Hardie fibre cement products. A dust-reducing saw uses a dust deflector or a dust collector connected to a vacuum system. When sawing, clamp a straight-edge to the sheet as a guide and run the saw base plate along the straight edge when making the cut.



Hole-Forming

For smooth clean cut circular holes:

Mark the centre of the hole on the sheet. Pre-drill a pilot hole. Using the pilot hole as a guide, cut the hole to the appropriate diameter with a hole saw fitted to a heavy duty electric drill.

For irregular holes:

Small rectangular or circular holes can be cut by drilling a series of small holes around the perimeter of the hole then tapping out the waste piece from the sheet face. Tap carefully to avoid damage to sheets, ensuring that the sheet edges are properly supported.



Storage and Handling

All James Hardie building products should be stored to avoid damage, with edges and corners of the sheets protected from chipping. James Hardie building products must be installed in a dry state and be protected from rain during transport and storage. The product must be laid flat under cover on a smooth level surface clear of the ground to avoid exposure to water or moisture, etc.

Quality

James Hardie conducts stringent quality checks to ensure that any product manufactured falls within our quality spectrum. It is the responsibility of the builder to ensure that the product meets aesthetic requirements before installation. James Hardie will not be responsible for rectifying obvious aesthetic surface variations following installation.

3.1 TIMBER FRAME

Timber framing must be in accordance with NZS 3604 Timber Frame Buildings.

Specific design to NZS 3603 and AS/NZS 1170 can also be undertaken providing that:

- the framing centres do not exceed those given in this specification
- the framing member widths conform to this specification.

Also refer to the Approved Document for NZBC Clause B2 ‘Durability’ and NZS 3602 (Timber and Wood-Based Products for use in Buildings) regarding timber treatment requirements and allowable moisture contents in timber for various components of the building. Also refer to the framing manufacturer’s literature for further guidance on the use of treated timber.

3.2 STEEL FRAME

The figures in this brochure are drawn for timber framing. However, steel framing and furring channels can also be used.

All metal framing centres are to be the same as specified for timber frame in this manual.

Steel framing members must be fabricated from light-gauge sheet steel 0.55mm thick minimum to 1.6mm maximum. If heavier sections are used difficulties may be experienced in fixing the self-drilling, self-tapping fasteners. Refer to specific details for the minimum flange width requirements.

Sheets must not be fixed directly to drawn steel or hot-rolled steel sections. These must first be battened out with ex 50mm-thick (40mm minimum) timber battens or light-gauge metal furring channels.

Screw-fix 6mm or thicker sheets only.

Screw fixings can be finished flush or sunk a maximum of 0.5mm below the sheet surface ready for filling.

NOTE: The fasteners must not be over driven as will reduce the holding capacity of the sheet.

3.3 FRAMING SET-OUT

For the framing set-out of 450mm and 600mm-wide soffit refer to Figure 1.

For the framing set-out of 750mm-wide soffits refer to Figure 2.

For the framing set-out of 900mm and 1200mm-wide soffit refer to Figure 3.

Pre-finished steel fascia/gutters

When pre-finished steel fascia/gutters are used the soffit edge must be supported 4mm min. into fascia recess, similar to Figure 27.

Ribbon board to be continuous for product fixing.

NOTE: Because of the limited fascia groove available with some metal fascias a supporting ribbon board will be required with fixings at 300mm centres maximum. Pre-finished soffits can distort due to surface tension when adequate edge support is not provided.

4 Installation

Table 12

Eaves Lining Framing Centres		
Eaves And Soffit Width (Mm)	Wind Zone	Max. Soffit Bearer Centres (Mm)
Up to 450	L, M	1200
	H, VH	900
451 - 600	L, M	1200
	H, VH	600
601 - 1200	L, M, H, VH, EH*	600

*HardieFlex Sheet 6mm or Villaboard Lining 6mm must be used in EH Wind Zone with soffit bearers maximum 600mm centres.

3.4 BATTEN REQUIREMENTS

Battens are required when sheets are fixed over:

- Gypsum board exceeding 20mm in thickness
- Softboard, polystyrene or similar
- Concrete, masonry block or brick.

Timber battening is to be a minimum of 35mm deep x 40mm wide to achieve adequate sheet nail penetration.

Steel battens must be minimum 0.55mm thick, 23mm deep and have a bearing surface of 38mm min. Battens must be galvanised to meet the durability requirements of the New Zealand Building Code (NZBC) and fixed to manufacturer's specifications. All battening centres and sheet fixing is to be strictly in accordance with the framing and fixing required by this manual. Care must be taken to ensure the battens are packed and aligned to give a true even surface for the sheets to be fixed. Check the face of the battens with a long straight-edge before fixing sheets.

3.5 SKILLION ROOF DESIGN

When installing soffit linings direct to skillion roof framing ensure that sufficient ventilation has been provided within the roof space. The temperatures within these smaller roof spaces can reach extreme levels in certain conditions and this can cause cracking in flush stopped joints due to excessive movement in framing. The framing in skillion soffits and ceiling also need engineering design consideration. General design guide is to provide control joints at 4.8m x 3.6m in either direction when fixing to this type of framing.

For narrow strip soffits provide control joints at 4.8m centres.

This installation manual covers the use of James Hardie Eaves and Soffits for buildings within the scope of NZS 3604. For all other buildings specific engineering design is required.

Figure 1: Eaves and soffits 450mm, 600mm wide

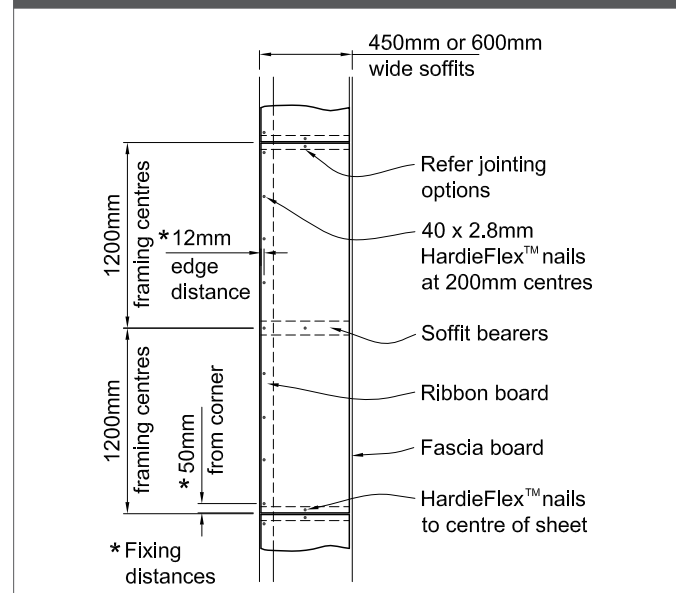
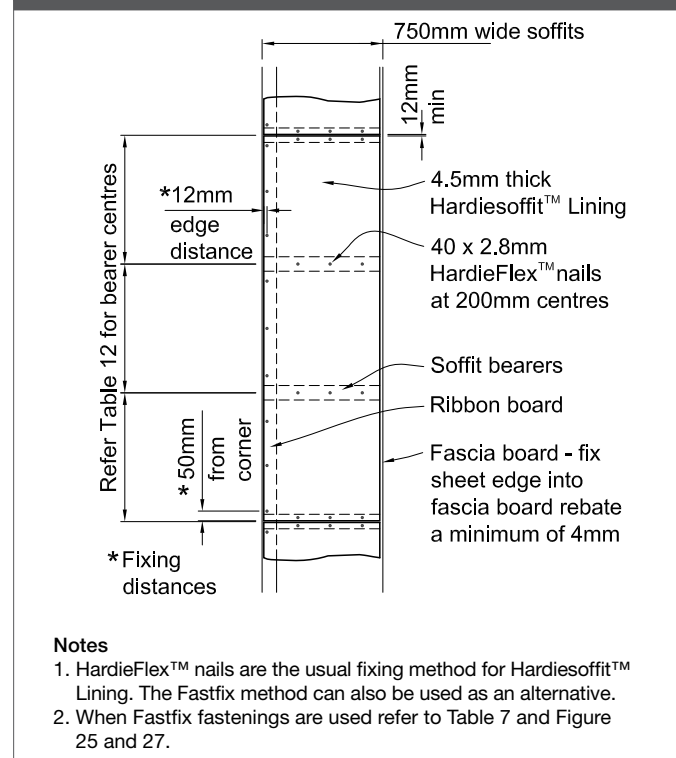

Figure 2: Eaves and soffits 750mm wide



Notes

1. HardieFlex™ nails are the usual fixing method for Hardiesoffit™ Lining. The Fastfix method can also be used as an alternative.
2. When Fastfix fastenings are used refer to Table 7 and Figure 25 and 27.

Figure 3: Eaves and soffits 900mm–1200mm wide

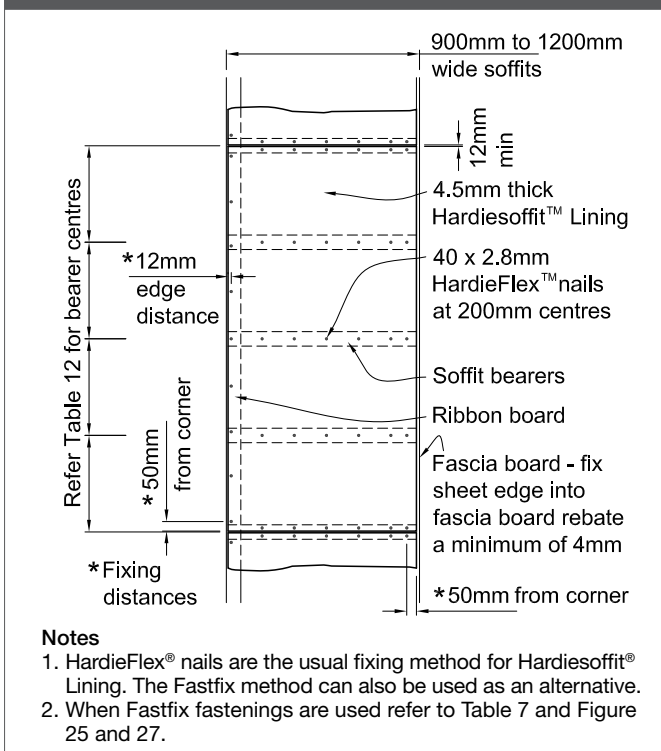

4.1 GENERAL

Refer to Table 12 and Figure 1, 2 and 3 regarding nail fixing centres, for framing and types of fasteners.

The eaves/soffits must be sealed against claddings to minimise moisture ingress behind the claddings. The roof must have been installed before installing the soffits linings. Where the soffits are sloping upwards away from the wall, a mechanical flashing must be provided in the soffit to wall junction. The flashing is fixed under soffit lining and laps over the face of cladding by 35mm min. Refer to Figure 18.

4.1.1 DRIP EDGE

All soffit linings must either be installed with a grooved fascia, refer Figure 13, or with exterior cladding which forms a drip edge below the soffit lining by 15mm min. Soffit linings are generally fitted into the recess formed in fascia board to form the drip edge.

4.1.2 STRUCTURAL CEILING DIAPHRAGMS

HardieFlex Eaves Lining and Villaboard Soffit Lining are suitable for use in structural ceiling diaphragms as per NZS 3604. Refer to the James Hardie Bracing Design Manual.

4.1.3 CURVED APPLICATIONS

HardieFlex Eaves Lining and Villaboard Soffit Lining can be used for curved applications.

The minimum bending radii are shown below.

Table 13

Curved Wall Minimum Bending Radii		
	Along length (mm)	Across width (mm)
9mm Villaboard Lining	3000	4000
6mm Villaboard Lining	1800	2400
HardieFlex Eaves Lining	1800	2400
Hardiesoffit Lining	1800	2400

NOTE: The bending radii given above require no special pre-wetting of the sheet. Mechanical fix at 200mm centres maximum.

To maintain the smoothness of the curve, ceiling battens are generally required at spacings as shown below.

Table 14

Curved Lining — Soffit Batten Spacing	
Range of Radii (mm)	Soffit batten spacing (mm)
1800	200
Above 1801 to 3000	300
Above 3001	400

4.1.4 FASTFIX FASTENERS

Fastfix fasteners (38mm long) can be used as an alternative fixing for prefinished soffit and ceiling systems in conjunction with adhesives. Drill a 6mm-diameter hole through the sheet and framing to insert the Fastfix fastener. In timber the hole must be 40mm deep.

4.1.5 MASKING TAPE

The recommended masking tape for use with Silcline Soffit Lining and Eclipsa Eaves Lining is 3M Scotch Blue painters tape 2090 or Sellotape 5855 longlife. This tape can only be left on the Silcline Soffit Lining or Eclipsa Eaves Lining for maximum 7 days, otherwise tape removal may cause paint loss.

4.1.6 FIRE RATED SOFFITS

A fire rating of 30 or 60 minutes can be achieved in a soffit when using 6mm or 9mm Villaboard Soffit Lining or 6mm or 7.5mm HardieFlex Sheet when James Hardie FRR wall systems are used. For full details refer to the James Hardie Fire and Acoustic Design Manual or Ask James Hardie on 0800 808 868.

4.2 FASTENER DURABILITY

Fasteners used in external applications must meet the minimum durability requirements of the NZBC. NZS 3604 specifies the requirements for fixing's material to be used in relation to the exposure conditions and are summarised in Table 15.

Table 15

Exposure conditions and nail selection prescribed by NZS 3604		
Zone / Nail Material		
Zone D*	Zone C outside sea spray zone and Zone B and geothermal hot spots	Bracing — All zones
Grade 316 Stainless	Hot-dipped galvanised or 316 stainless	Grade 316 Stainless

* (Zone C areas where local knowledge dictates that increased durability is required, appropriate selection shall be made)

When using screws to fix into steel framing a minimum class-3 coated screw must be used.

4.3 HARDIESOFFIT LINING

For framing and fixing schedules refer to Section 3.

All sheet edges are to be supported by framing or a fascia board. Fixings are to be at 200mm centres to all framing (refer Figures 1 and 2).

Hardiesoffit Lining up to a max. width of 600mm can be jointed up to a maximum 150mm off the ceiling/soffit batten when using uPVC jointers.

NOTES

1. Use of 6mm thick sheets will minimise the deflection and enhance the impact resistance.
2. Sheets can be jointed as per Section 4.
3. Do not screw fix 4.5mm thick sheets.

4.4 HARDIEFLEX EAVES LINING

For framing and fixing schedules refer to Section 3.

All sheet edges are to be supported by framing or a fascia board. Fixings are to be at 200mm centres to all framing (refer Figures 1 and 2).

NOTES

1. Use of 6mm thick sheets will minimise the deflection and enhance the impact resistance.
2. Sheets can be jointed as per Section 4.
3. Do not screw fix 4.5mm thick sheets.

4.5 HARDIEGROOVE SOFFIT LINING FIXING METHOD

For framing and fixing schedules refer to Section 3.

The recommended fixing methods are combined nail and adhesive or screw and adhesive. However, screw or nail fixing only is an option. (Refer Figure 4).

To achieve a concealed joint, butt the long edges together (half-grooved). (Refer Figure 5).

Figure 4: Nail or screw and adhesive fixing

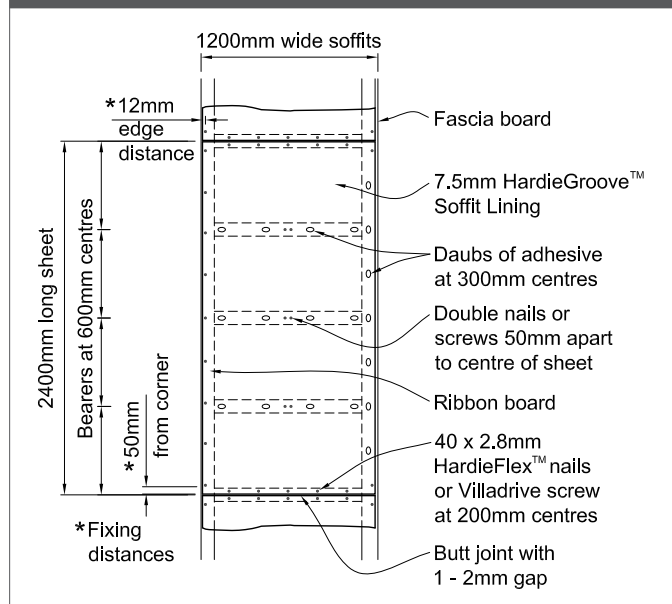

NOTES

1. Do not place nails or screws within 100mm of the adhesive daubs.
2. Suitable fixings are HardieDrive stainless steel 30mm x 7g wood screws, HardieFlex galvanised nails 40 x 2.8mm and 316 stainless steel nails 40 x 2.8mm.
3. Use only stainless steel fixings in sea spray zones.
4. When butt jointing short ends of HardieGroove Lining in ceiling/soffit applications, the short edges must be cut square and have chamfer formed.

Nails must be finished flush with the sheet surface. Screw heads can be finished 1-2mm below the sheet surface and stopped.

In steel framing the fasteners should be driven as close as possible to the stud corners to avoid deflection of the stud flange.

Figure 5: Sheet edge and groove detail

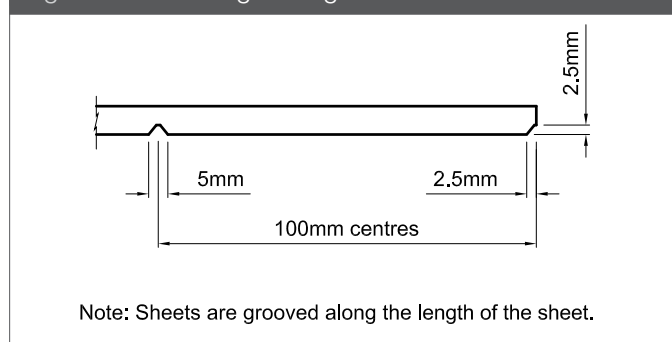

Note: Sheets are grooved along the length of the sheet.

4.5.1 FINISHING

Once the sheets are in place, fill over all driven fixings with James Hardie Base Coat to the required level of finish.

4.6 ECLIPSA EAVES LINING AND SILKLINE SOFFIT LINING

- Eclipsa Eaves Lining/Silkline Soffit Lining are to be supported by bearers and fasteners at the maximum spacings specified for the 4.5mm sheets in Section 3, Table 12 and Figures 22, 25 and 26 of this manual
- To fix larger soffit, ceiling or verandah applications provide a perimeter frame to all sheet edges and intermediate nogging at the centres shown in Table 12.
- Fix the Eclipsa Eaves Lining/Silkline Soffit Lining into the fascia board groove then nail into the ribbon board at 300mm centres with 40 x 2.8mm HardieFlex nails. Ensure nails will be hidden by the scotia mould or timber scotia (refer Figure 27 and Figure 28).
- Use a 6mm-diameter masonry bit to drill holes and fix Fastfix fasteners (refer Figures 6 and 25).
- Eclipsa Eaves Lining/Silkline Soffit Lining up to a maximum 600mm width can be jointed up to a maximum 150mm off the ceiling/soffit batten when using uPVC jointers.

Figure 6: Fastfix fastener and adhesive fixing

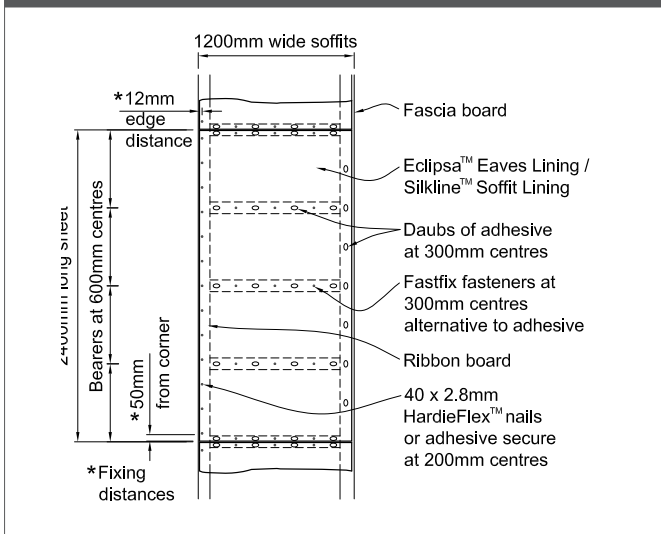

4.7 VILLABOARD SOFFIT LINING (SMALL SOFFITS)

Villaboard Lining 6mm-thick is used when a smooth sanded sheet is required to achieve a painted flush finish.

Refer to the framing fixing schedule Section 3 Table 12, Figures 1, 2 and 3, and finishing schedules on page 21.

Refer to the flush jointing procedures, pages 21-24.

Figure 7: Nail/screw and adhesive fixed soffit

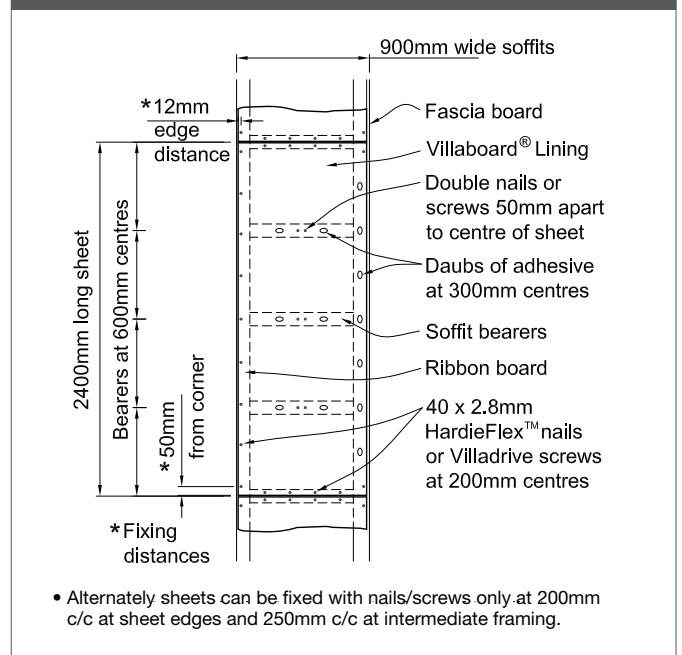
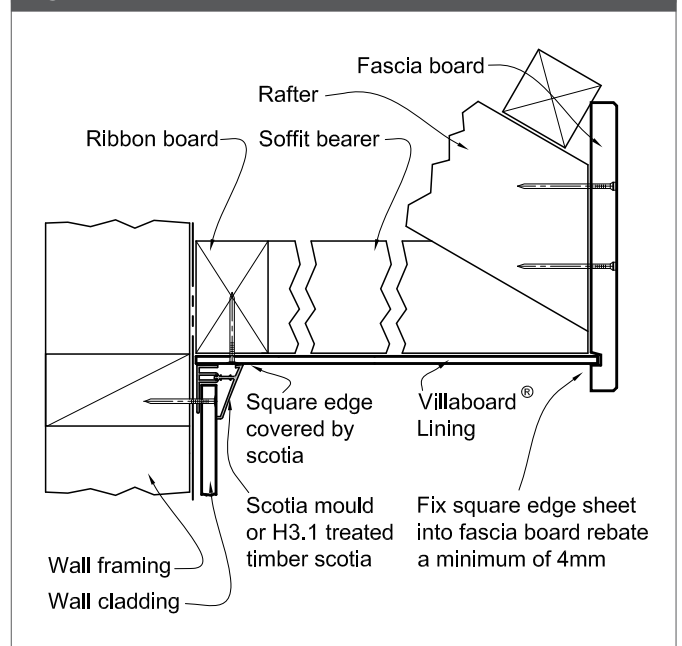

Figure 8: Soffit cross section



4.7.1 CONTROL JOINTS

Control joints are required in long runs of Villaboard Lining soffits/ceilings to accommodate structural movement. Control joints must also be provided where the soffits change in direction, change in level, where there is a construction joint in framing or where the soffits continue into passage ways etc. See Table 16 for maximum control joint spacing and Figure 9 for a typical control joint detail.

4.7.2 JOINTING OPTIONS

Villaboard Soffit Lining is suitable for:

- Flush-jointed narrow strip soffits around a building
- Flush-jointed ceilings over verandahs, porches and entryways to residential and small-scale commercial buildings
- Expressed, uPVC-jointed and sealant-filled joint ceilings where a smooth surface finish is required
- All edges to be supported by the framing.

Table 16

Maximum spacing for control joints (m)		
	STEEL FRAMING	TIMBER FRAMING
General	4.8	7.2

When these ceilings are wider than one sheet width the sheets can be fixed to the framing provided the control joints are placed to limit the bay size to 7.2m x 4.8m maximum.

4.7.3 NARROW-STRIP FLUSH-JOINTED SOFFITS AND CEILINGS

In these applications sheets must be jointed on the framing as shown in Figures 1, 2, 15 and 16. Control joints, as shown in Figure 9, must be located at a distance as specified in Table 16 above. Sheets must not be fixed to the bottom cord of roof trusses.

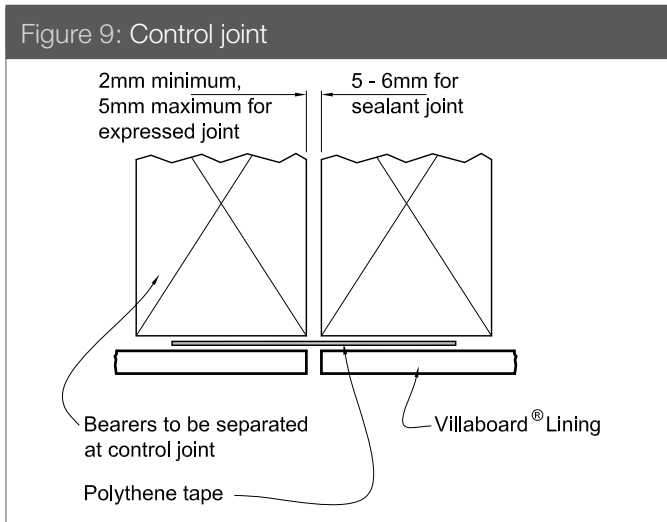

NOTE

Refer Section 3.5 for skillion roof design.

4.7.4 VILLABOARD SOFFIT AND CEILING LINING (large areas)

For standard commercial soffits and ceilings, framing must be at 600mm maximum centres and 6mm thick Villaboard Soffit Lining can be used. For high-impact areas, heavy-use commercial areas, and high-wind areas, framing at 600mm maximum centres and 9mm thick Villaboard Soffit Lining should be used. Sheets must not be fixed to the bottom cord of roof trusses. Timber or steel ceiling battens must be fixed to the underside of the roof truss. Sheets must be

laid in an offset pattern so that adjacent end joints do not coincide. Timber ceiling battens must comply with the requirements of NZS 3604 or the specific engineering design. Steel ceiling battens must be a minimum of 37mm wide x 23mm deep x 0.55mm thick and have a bearing surface of 37mm minimum. Battens must be galvanised steel (275 g/m² zinc coating), have a suitable coating to meet the durability requirements and be fixed to the manufacturer's specifications. Refer to the flush-jointing and finishing procedures on pages 21-24.

For specific engineering design projects consideration must be given to framing deflections expected due to loadings and appropriate selection of sheet jointing method must be made.

For skillion roof design refer to Clause 3.5 for further design consideration.

NOTE

1. It is recommended that flush stopping of joints is suitable when using recessed edge Villaboard Lining.
2. When noggs not installed for perimeter support, the unsupported sheet edges across the framing must be supported by back blocking using a 300 – 400mm wide Villaboard Lining strip adhered to rear face and centred between the framing.

Figure 10: Ceiling layout

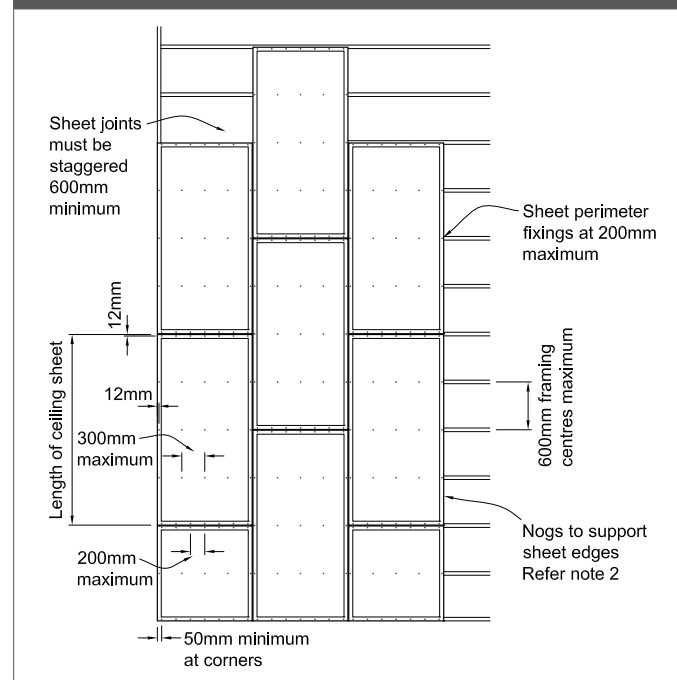

4.7.5 CONTROL JOINTS

The ceilings must be divided into bays not exceeding 7.2 x 4.8m. To permit movement, control joints must be formed at the perimeter of each bay (refer Figures 11, 12, 13 and 14) and at the junction of large ceilings with narrow passage strips or where there is a change in direction (also refer Figures 12 and 13). Each bay must be independent of adjacent bays and the surrounding building structure. When the ceilings or soffits contain sloping areas then control joint centres must be reduced to coincide with the slope

change lines (refer Figure 14). Framing members (to which the sheet is fixed) must not continue across this control joint. Sheets shall be fixed across the ceiling joists or ceiling battens (refer Figures 15 and 16). Figures 12 and 13 show control joints with the battens running in the same direction as the sheet joint.

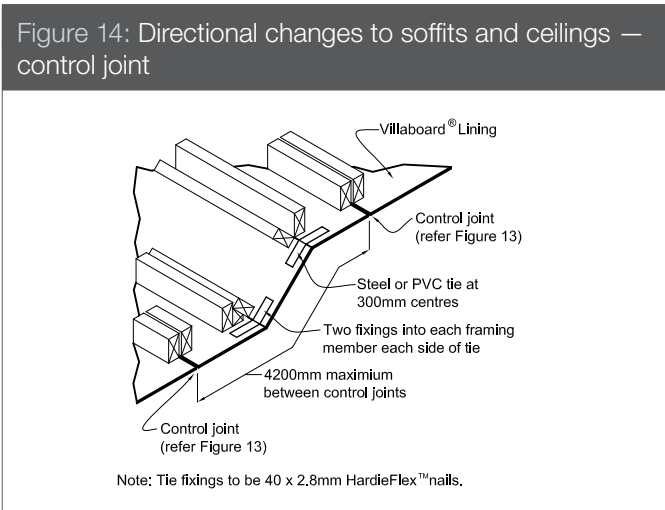
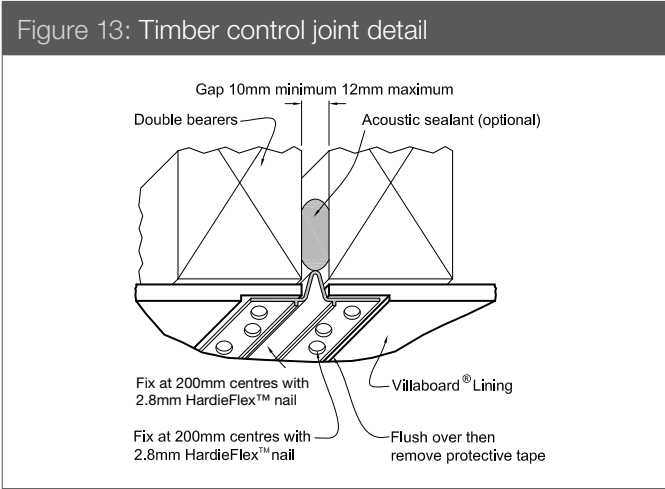
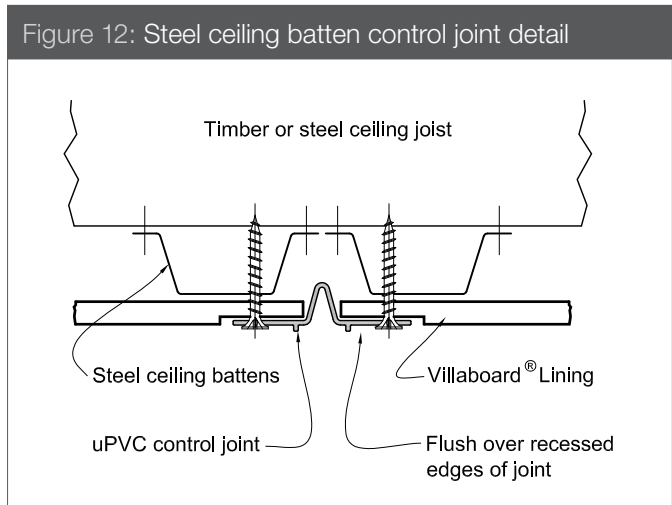
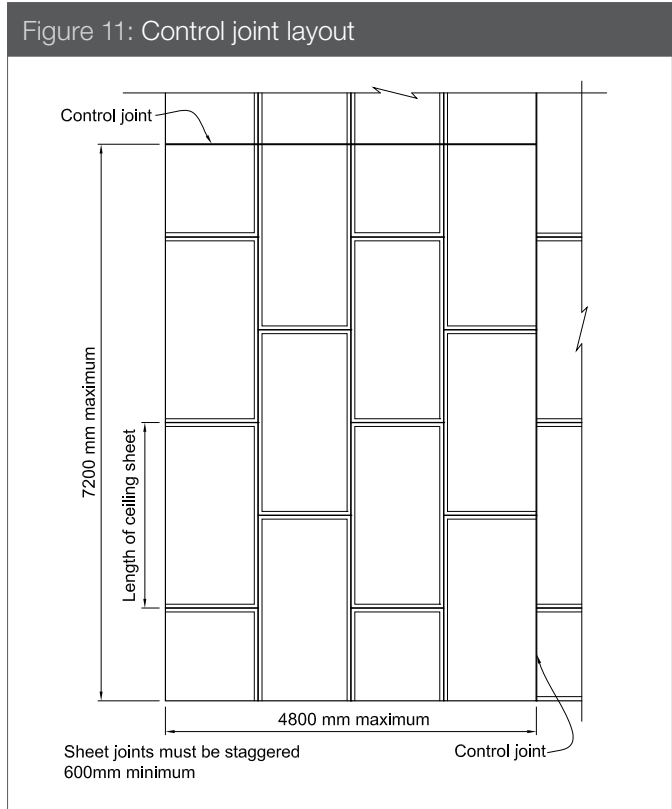

4.7.6 FIXING OPTION ONE

A smooth surface finish is obtained by minimising the visible sheet fixings. For painted finishes the combined nail or screw and adhesive method gives this superior finish (refer Figure 19).

Fix at 200mm centres down each sheet end with edge fixings in each joist or batten. Double-fix in the centre of each joist or batten (refer Figure 19). Do not place nails or screws within 100mm of adhesive daubs. Daubs of wallboard adhesive 25mm diameter and 15mm thick must be applied to the intermediate joists or battens at 250mm centres (refer Figure 19).

When nogs are not installed for perimeter support, the unsupported edges between ceiling joists or battens must be supported with back blocking using a 300-400mm wide Villaboard Lining strip adhered to rear face and centred between framing.

Figure 15: Nail or screw and adhesive fixing

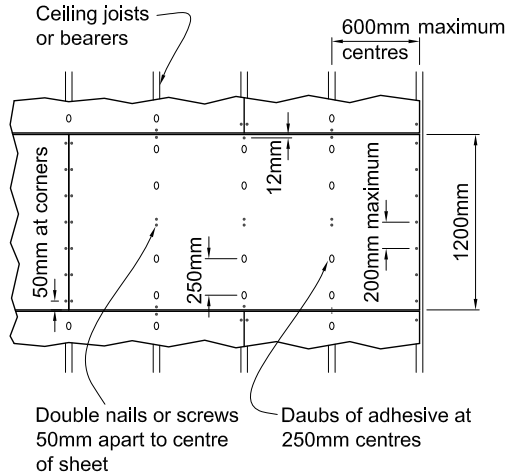

NOTES

1. All surfaces to receive adhesive must be clean, free of dust, oil etc.
2. Ensure daubs of adhesive never coincide with permanent fastener points, as adhesive shrinkage may cause fastener head protrusion.

4.7.7 FIXING OPTION TWO

For an alternative nail or screw-fixing method, fasteners are to be driven along the sheet perimeter at 200mm centres and along intermediate ceiling battens at 250mm centres (refer Figure 16).

When noggs are not installed for perimeter support, the unsupported edges between ceiling joists or battens must be supported with back blocking using a 300-400mm wide Villaboard Lining strip adhered to rear face and centred between framing.

Figure 16: Nail or screw

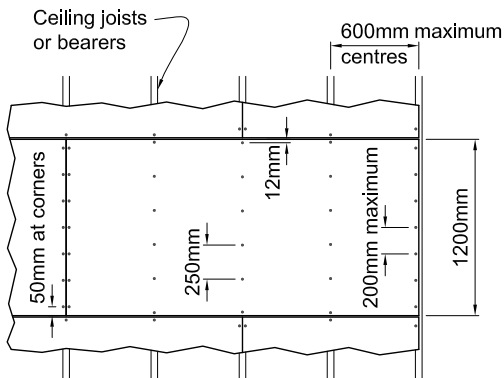

4.7.8 COLUMN OR WALL ABUTMENTS

Soffit sheeting must be free to move independently from the building element it abuts with. This is critical for flush-jointed sheeting, otherwise cracking at the joint may occur.

4.7.9 BULKHEAD IN SOFFITS

The bulkhead made in soffits is generally used to carry the services through them and they can be lined with Villaboard Soffit Lining. The box framing provided must be rigid enough to carry its weight and/or services. It must provide support to all sheet edges and joints. The external/internal corner of a bulkhead can either be stopped using a James Hardie PVC corner mould or a 'proprietary paper faced rigid spine' corner mould.

**Paper faced rigid spine corner mould is generally available in the market.*

4.7.10 SQUARE-EDGE VILLABOARD LINING CEILING AND SOFFITS

Square-edge Villaboard Lining is used for butt-joint; expressed-joint or uPVC-jointed ceilings.

4.8 TITAN FACADE PANEL

May be used as soffit with expressed joint when installed as per Figure 23 and fixings as per Villaboard Soffit Lining.

4.9 INTERNAL SWIMMING POOL APPLICATION

For fixing Villaboard Lining and HardieGroove Lining in internal swimming pool areas;

- The sheets must be back and edge sealed before installation.
- When fixing Villaboard Lining to the ceiling under a skillion roof, roof ventilation must be considered to minimise thermal movement and sheet joint cracking.
- All Villaboard Lining recessed sheet joints must be stopped. Alternatively, when using square edge Villaboard Lining, the sheet joint must be butted over an Inseal 3259 tape with an appropriate flexible sealant in the 1mm joint.
- All HardieGroove Lining joints must have continuous bead of sealant applied to edge of sheet before butting together.
- Only stainless steel fasteners must be used.
- Full perimeter fixing required.
- In addition, it is recommended that H3.1 treated timber ceiling battens are used to resist decay due to higher condensation levels present in this area.

Figure 17: Sheets laid along ceiling joists (expressed or butt joints)

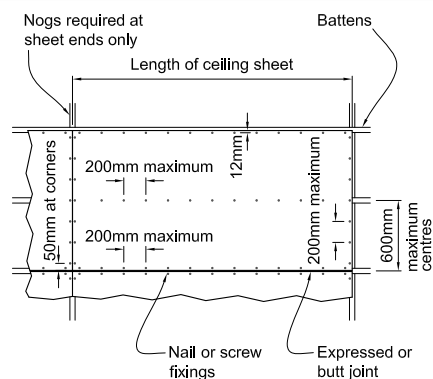

5 Jointing options

4.10 SPECIAL DETAILS

Figure 18: Sloping soffit and wall junction

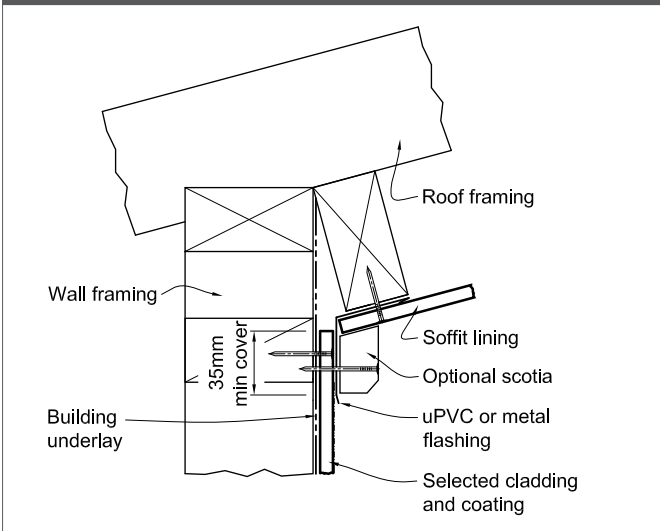

Figure 19: Gable elevation

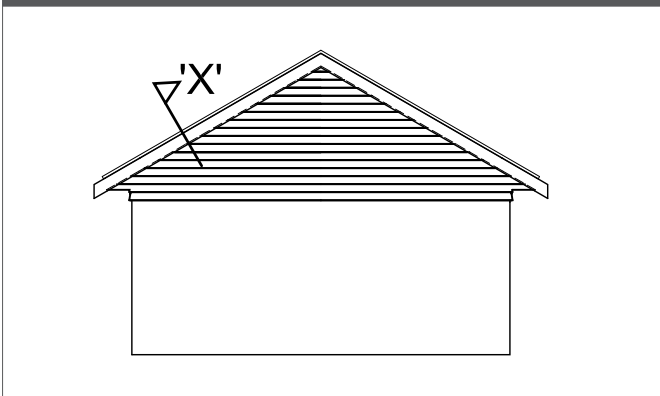
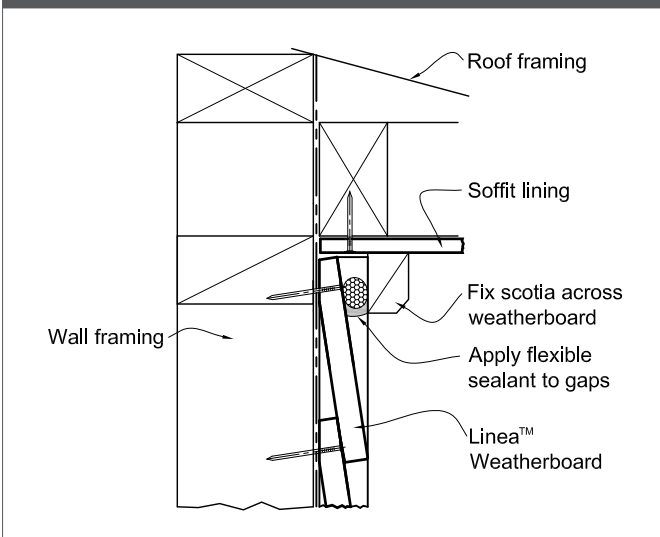

Figure 20: Sloping soffit to weatherboard cladding junction (Section 'X')



- All soffit lining sheet edges must be supported by framing and/or a fascia board.

HARDIEFLEX EAVES LINING

- Refer to Figure 22 for uPVC Hardiejointer detail
- Refer to Figure 23 for express joint detail
- Refer to Figure 24 for butt joint detail
- Refer to Figure 26 for two-way uPVC jointer

HARDIEGROOVE SOFFIT LINING

- Sheets have half groove along the long edges for butt jointing
- Sheets to have chamfer formed on site along the short edge for butt jointing

HARDIESOFFIT LINING

- Refer to Figure 22 for uPVC Hardiejointer detail
- Refer to Figure 23 for express joint detail
- Refer to Figure 26 for two-way uPVC jointer

ECLIPSA EAVES LINING

- Refer to Figure 22 for uPVC Hardiejointer detail
- Refer to Figure 25 for Fastfix Fasteners fixing detail. Use a 6mm diameter masonry drill bit to drill a hole and fix fasteners
- Refer to Figure 26 for Two-way uPVC Jointer

SILKLINE SOFFIT LINING

- Refer to Figure 22 for uPVC Hardiejointer detail
- Refer to Figure 25 for Fastfix Fasteners fixing detail. Use a 6mm diameter masonry drill bit to drill a hole and fix fasteners
- Refer to Figure 9 for two-way uPVC jointer

VILLABOARD SOFFIT LINING

- Refer to Figure 21 for flush joint details. Refer to Section 5.5 for flush jointing
- Refer to Figure 22 for uPVC Hardiejointer detail
- Refer to Figure 23 for express joint detail
- Refer to Figure 24 for butt joint detail

Figure 21: Vertical flush joint setout

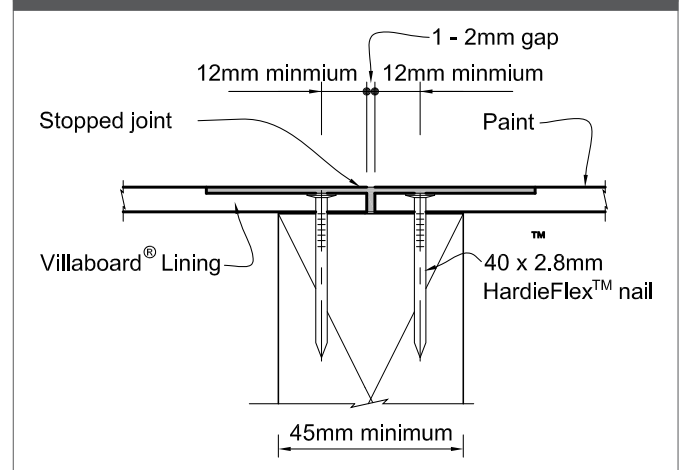

Figure 22: uPVC Hardiejointer detail

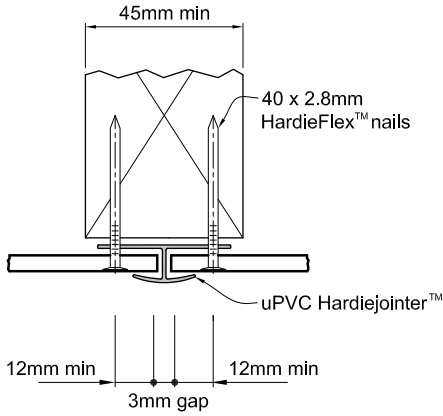

Figure 26: Two-way uPVC jointer

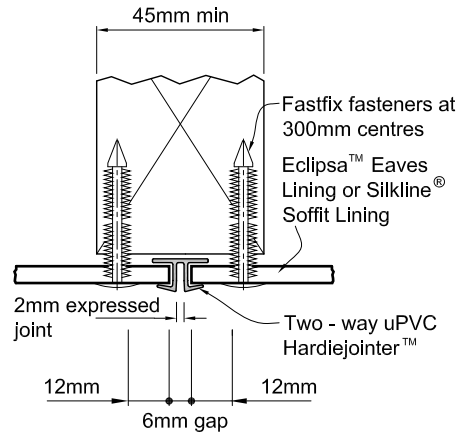

Figure 23: Exposed joint detail

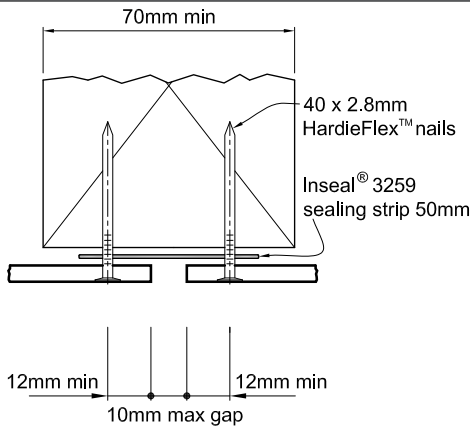

Figure 27: Cladding detail with scotia mould

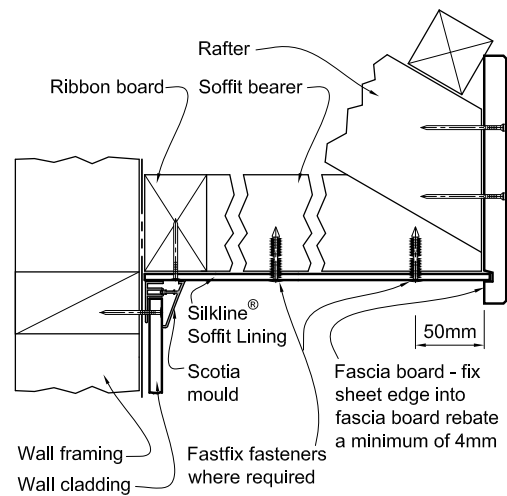

Figure 24: Butt joint detail

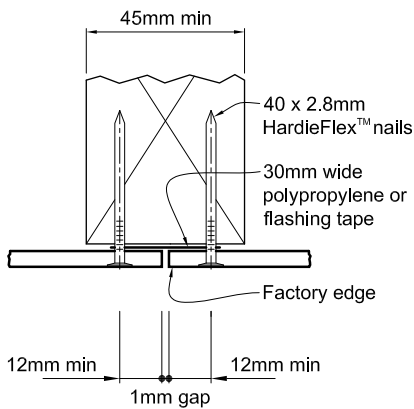

Figure 28: Brick veneer detail with scotia mould

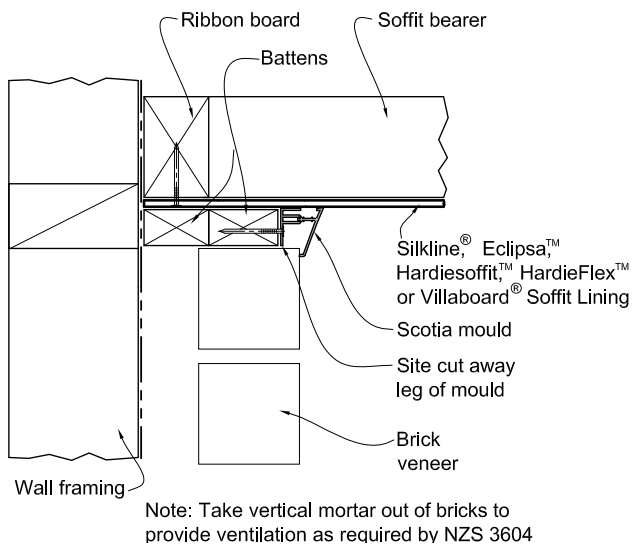
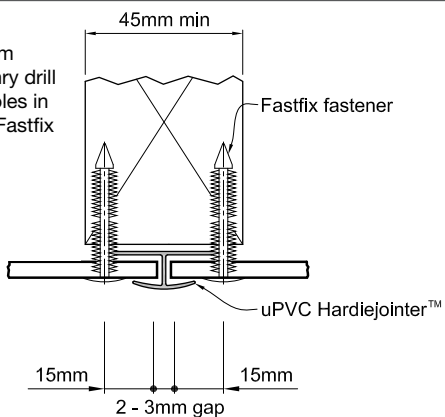

Figure 25: Fastfix fastener fixing detail

Note: Use a 6mm diameter masonry drill bit for drilling holes in sheet for fixing Fastfix fasteners.



6 JOINTING AND FINISHING

FOR VILLABOARD LINING

6.1 GENERAL

Villaboard Soffit Lining is finished with paint complying with parts 7, 8, 9 and 10 of AS 3730. The application and maintenance must be in accordance with the manufacturer's specifications.

NOTE: Before flush stopping sheet edges must be sealed with Multiplast resin, water proofing admixture or other similar products.

6.2 GLANCING LIGHT

In some instances, due to glancing light, set joints may be noticeable in Villaboard Lining walls, especially where paint finishes have a high gloss level. Work closely with your builder or designer to minimise this.

Artificial lighting needs to be considered in relation to soffits.

Where glancing light is an issue its effect can be lessened by:

- Artificial light shading devices.
- The use of light coloured, matt finish paints.

6.3 LEVEL OF FINISHES

Different levels of finishes are typically specified for different applications. Higher levels of finishes are used to address the glancing light issues with painted Villaboard Soffit Lining referred to above. A description of the various levels of finishes and the jointing/coating requirements can be found in Table 17.

Table 17

Levels of Finishes			
Level of finish	Definition*	Typical jointing/setting	Finish
0	This level of finish may be useful in temporary construction.	No stopping, taping, finishing or accessories are required. The work is confined to gluing or screwing/nailing sheets in place.	For use in areas where finishing and stopping is not considered necessary.
1	For use in plenum areas above ceilings, in areas where the work would generally be concealed, or in building service corridors and other areas not normally open to public view.	Joints and corner joints will be set with James Hardie Base Coat reinforced with perforated paper tape.	Surface free from excess jointing compound. Tool marks and ridges are generally acceptable.
2	For use in warehouse, storage or other areas where surface appearance is not of primary concern.	Joints and corner joints will be set with James Hardie Base Coat reinforced with perforated paper tape and James Hardie Top Coat.	Minor tool marks and ridges are generally acceptable.
3	For use in areas which are to receive heavy or medium texture (spray or hand applied) finishes or where heavy wall paper coverings are to be applied as the final decoration. This level of finish is not generally suitable where smooth painted surfaces or light to medium wall coverings are specified.	Joints and corner joints will be set with James Hardie Base Coat reinforced with perforated paper tape and James Hardie Top Coat.	This level of finish must be sufficiently smooth to accept heavy vinyl, tiles or textured coatings without blemishes.
4	This is generally the accepted level of finish for domestic construction. It is used where light textures or wall coverings and smooth textured finishes and satin/flat/low sheen paints are illuminated by non-critical lighting.	Refer to flush jointing recommendations on page 22. All joints and corner joints will have tape embedded in James Hardie Base Coat applied over all joints, angles, fastener heads and accessories. This application is applicable to recessed edge sheets only. The use of square edge sheets will require a high build application and coating finish.	For use where light-texture coatings or wallpaper or other lightweight wall coverings are to be applied. For painted finishes in non-critical lighting areas flat and low-sheen textured paints are to be applied. Gloss and semi-gloss paints are not generally suitable over this level of finish as any minor blemish will show under critical light. The weight, texture and sheen level or wall coverings applied over this level of finish must be carefully evaluated. Joints and fasteners must be adequately concealed if the wall-covering material is lightweight, contains limited pattern, has a gloss finish, or any combination of these features is present. Unbacked vinyl wall coverings are not suitable over this level of finish.
5	This level of finish is for use where gloss or semi-gloss paints are specified or where critical lighting conditions occur on satin, flat or low sheet paints.	Refer to page 23 steps 1–4 for jointing. Final James Hardie Base Coat application should be feathered out to approximately 200mm + each side of the joint. Then a full skim coat of James Hardie Top Coat must be applied over entire sheet surface in order to achieve a uniform finish. This application is applicable to recessed edge sheets only. The use of square edge sheets will require a high build application and coating finish.	This level of finish is for use where gloss, semi-gloss, low-sheen or non-textured paints are specified or where critical lighting conditions occur.

*Reference: AS/NZS 2589.1: 'Gypsum lining in residential and light commercial construction — Application and finishing. Part 1: Gypsum plasterboard'

6.4 PAINT FINISHES

Prior to application of paint finishes, remove any residual sanding dust and ensure the surface is suitable for paint application.

Always follow the paint manufacturer's recommendations for paint suitability, mixing and application.

NOTES

1. Use of a 'sealer coat' or 'preparation undercoat' is recommended.
2. Do not tile ceilings.

6.5 VILLABOARD SOFFIT LINING JOINTING AND STOPPING

Villaboard Soffit Lining joints are set with James Hardie jointing compounds reinforced with perforated paper tape. Recessed edge sheet joints require joint setting by using the jointing products outlined. The performance of joints is the responsibility of the installer, as this is governed by the installation practices and the standard of workmanship applied. However, James Hardie considers that the recommendations provided in Table 17 describe best practice to reduce the risk of joint cracking or other problems. There are various factors that can affect the performance of jointing compounds on edge recessed fibre cement substrates. These factors include the framing, movement, installation quality, vibrations, moisture, humidity, temperature, etc. To achieve satisfactory joint performance these factors need to be carefully considered and understood by the installer and designer when positioning joints and selecting jointing compounds. Furthermore, it is important that the jointing compound used has the physical attributes required to perform considering these factors. James Hardie compounds have been specifically developed for use with Villaboard Soffit Lining.

In addition, provision for movement needs to be made by the installation of control joints. See page 16.

COMPOUND COVERAGE

1kg of Base Coat will provide approximately 5 lm of standard joints.

1kg of Top Coat will provide approximately 5.6 lm of standard joints.

NOTE

Follow the mixing instructions carefully when mixing James Hardie Base Coat and Top Coat.

MIXING INSTRUCTIONS

Table 18

James Hardie Base Coat Mixing Instructions

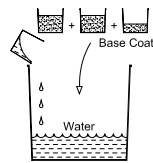

Step 1

First, add 1 part of clean water into bucket.

Then add 2½ parts James Hardie Base Coat powder

Allow to soak for 1 minute.

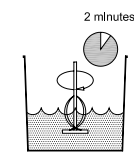
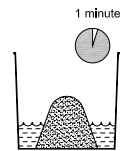

Step 2

Mix for 1½ – 2 minutes using paint mixer or equivalent. (approximately 2500-3000rpm)

James Hardie Base Coat is NOT like the plaster based compounds. Initial mixing will indicate a dry mix and further mixing **WITHOUT** further addition of water will deliver the ideal workable paste.

Warning: Inadequate or over mixing can lead to poor workability and can cause performance issues. **Do not hand mix.**

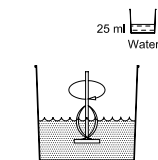

Step 3

The mix at this stage should be consistently smooth.

Based on the environmental conditions (i.e. temperature and humidity) you may add maximum of 25ml of water per 1Kg of base coat powder in the mix at this stage to adjust workability. Mix it well.

(Note: Adding excess water than the recommendation may delay the drying of base coat and may cause joint cracking due to excessive shrinkage.)

Mix should be glossy and smooth. There should be no lumps in the mix.

Important Notes:

1. Do not apply James Hardie Base Coat in temperatures above 40° C or below 5° C.
2. Allow the compounds to dry before applying the next coat. The drying time will vary between 12 to 24 hours depending upon the weather conditions.
3. Site cut and site recessed sheet edges must be sealed with an acrylic sealer e.g. Dulux Acraprime 501/1, Dulux Primercrl or similar product.
4. In corners, use James Hardie uPVC internal/external corner mould primed with Dulux Primerlock or similar. A 'GIB® Goldline™ Platinum' corner mould can also be used.
5. Use only perforated paper tapes in straight joints.
6. It is recommended that one (1) base coat bag is mixed in three (3) portions.
7. Before stopping the sheet edges, Multiplast Resin or a similar product in diluted form must be applied over the sheet edges. Mix the resin as per the manufacturers recommendations.

Product Life:

James Hardie Base Coat has a shelf life of 12 months in unopened bags when stored in a cool dry place.

James Hardie Base Coat has a bag life of 1 month if opened bags are resealed and stored in a cool dry place.

6.6 SET JOINTS

Step 1 – Preparation

Ensure that the recesses are clean and free of dust and contaminants. Sheet edges must be sealed with Multiplast resin, water proofing admixture or other similar products. If working conditions are hot and dry, dampen the area around the joint prior to working.

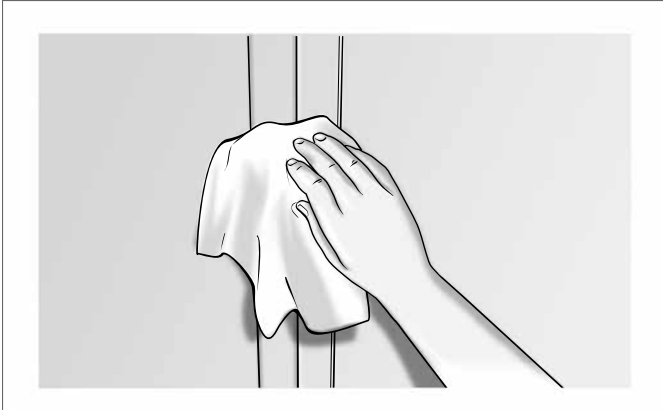

NOTE

The jointing method shown below provides a Level 4 finish. For more information about this and other finishes refer to page 21.

Step 2 – First Coat

Apply James Hardie Base Coat to fill the recess with a 150mm broad knife.

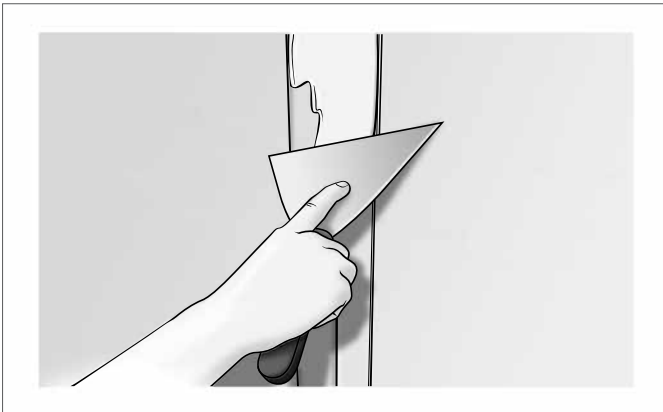

Step 3 – Embed Tape

Firmly embed the perforated paper tape centrally into the joint using a 50mm broad knife. Ensure that there are no voids under the tape and remove excess compounds.

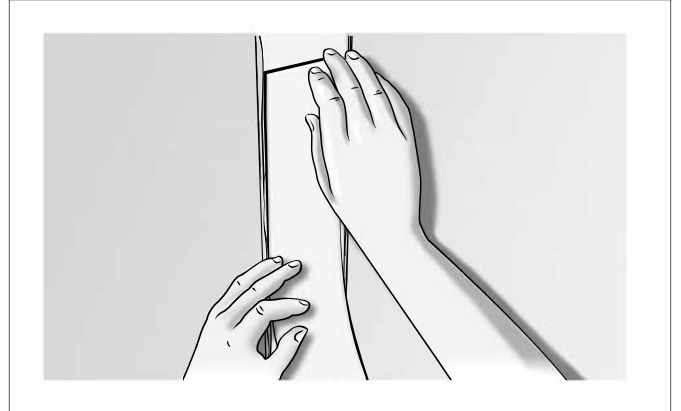

Step 4 – Thin Layer

Immediately cover tape with a thin layer of James Hardie Base Coat applied with a 150mm broadknife.

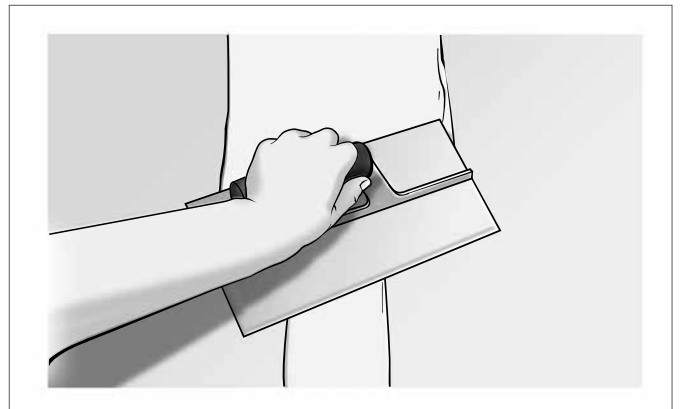

NOTE

Steps 5, 6 and 7 are only required for paint and wall paper finish.

Step 5 – Second Coat

When the first coat is fully dry, use a 200mm wide second coat trowel to apply the James Hardie Base Coat. Apply this coat approximately 180mm wide, laid down over the recess and feather the edges.

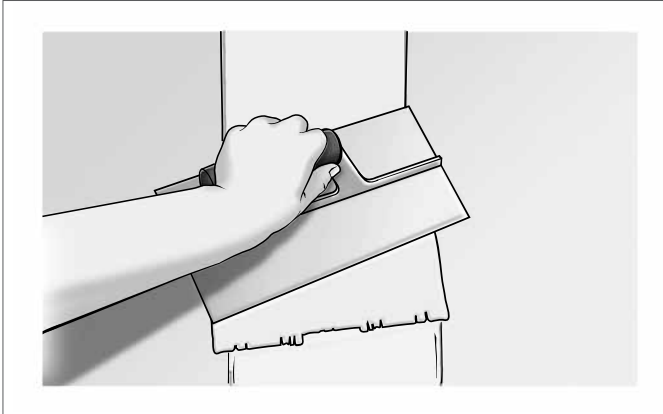

Step 7 – Fastener Heads

Apply a finishing coat of James Hardie Base Coat to fastener heads, feathering out the edges. Allow to fully dry before sanding.

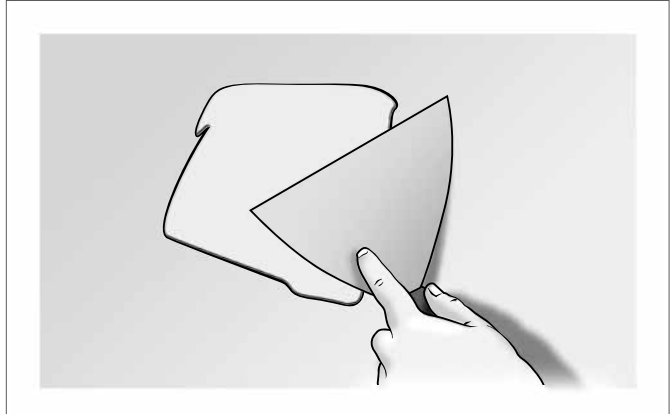

Step 6 – Finishing Coat

Ensure the second coat is fully dry. Using a finishing trowel, apply a coat of James Hardie Top Coat 280mm wide centrally over the joint and feather out the edges. Allow to dry fully before sanding. Sand with a 180 grit sand paper to achieve a smooth finish for painting.

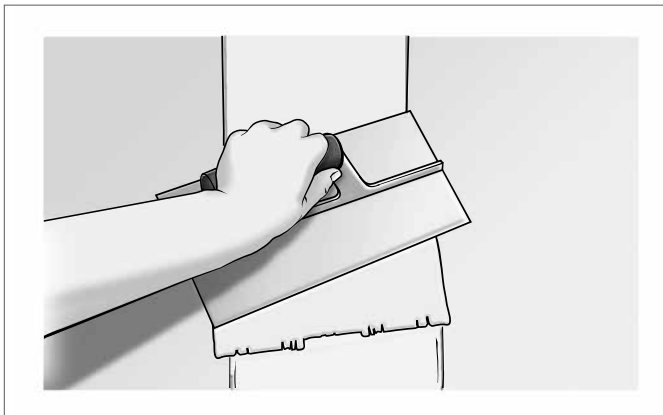

6.7 PAINTING

Hardiesoffit Lining, HardieFlex Eaves Lining, Villaboard Soffit Lining and HardieGroove Soffit Lining sheets are to have a minimum of two coats of acrylic paint applied after fixing in order to meet the requirements of the NZBC. All sheets must be coated within 3 months of installation.

Use quality 100% acrylic paints. Economy paints are not recommended because generally they are less well bound, less moisture resistant and more prone to mould growth.

In all cases the manufacturer's specification for the selected paint must be followed. Note that some paints require an undercoat before applying finish coats.

Damp, shady situations, proximity to bush, agricultural paddocks or seaspray environments may induce an extra tendency to mould growth. Use mould-inhibiting and alkaline-resistant undercoats and consult the paint manufacturer for details of maximum mould-resistant paints.

Before painting, remove any surface grime or other contaminants and ensure the Hardiesoffit Lining, HardieFlex Eaves Lining, Villaboard Soffit Lining and HardieGroove Soffit Lining is dry. Paint must not be applied when the air temperature is below 10°C.

When using uPVC moulds avoid dark colours (paints must have light reflection of 40% or more) as excessive movement may cause buckling of the uPVC when exposed to direct sunlight.

Enamel-based paints can be used, utilising a three-coat system.

For full details apply to the selected paint manufacturer before commencing the work.

7 Product information

7.1 GENERAL

Eclipsa Eaves Lining, Silkline Soffit Lining, Villaboard Soffit Lining, HardieGroove Soffit Lining, Hardiesoffit Lining and HardieFlex Eaves Lining are a cellulose fibre reinforced cement building product. The basic composition is Portland cement, ground sand, cellulose fibre and water.

Eclipsa Eaves Lining, Silkline Soffit Lining, Villaboard Soffit Lining, HardieGroove Soffit Lining, Hardiesoffit Lining and HardieFlex Eaves Lining is manufactured to AS/NZS 2908.2 'Cellulose-Cement Products Part 2: Flat Sheets' (ISO 8336 'Fibre Cement Flat Sheets').

James Hardie New Zealand is an ISO 9001 'Telarc' certified manufacturer. Eclipsa Eaves Lining, Silkline Soffit Lining, Villaboard Soffit Lining, HardieGroove Soffit Lining, Hardiesoffit Lining and HardieFlex Eaves Lining are classified Type A, Category 3 in accordance with AS/NZS 2908.2 'Cellulose-Cement Products'.

For Safety Data Sheets (SDS) visit www.jameshardie.co.nz or Ask James Hardie on 0800 808 868.

7.2 DURABILITY

Resistance to moisture/rotting

Eclipsa Eaves Lining, Silkline Soffit Lining, Villaboard Soffit Lining, HardieGroove Soffit Lining, Hardiesoffit Lining and HardieFlex Eaves Lining has demonstrated resistance to permanent moisture induced deterioration (rotting) and has passed the following tests in accordance with AS/NZS 2908.2:

- Water permeability (Clause 8.2.2)
- Warm water (Clause 8.2.4)
- Heat rain (Clause 6.5)
- Soak dry (Clause 8.2.5)

7.3 FINISHES

Villaboard Soffit Lining, HardieGroove Soffit Lining, Hardiesoffit Lining and HardieFlex Eaves Lining must be paint finished within 90 days of their installation. Refer to the paint manufacturer for paint suitability, mixing and application.

8 Maintenance

It is the responsibility of the specifier to determine normal maintenance requirements for eaves and soffits to comply with NZBC Acceptable Solution B2/AS1. The extent and nature of maintenance will depend on the geographical location and exposure of the building. As a guide, it is recommended that basic normal maintenance tasks shall include but not be limited to:

- Washing down exterior surfaces every 6-12 months*,
- Pre-painted soffits, such as Silkline Soffit Lining and Eclipsa Soffit Lining, when used in harsh coastal environments, the soffit must be washed down using a hose and soft brush minimum once every four months in addition to the other maintenance requirements,
- Re-applying exterior protective finishes**,
- Maintaining the exterior envelope and connections including joints, penetrations, flashings and sealants,
- Cleaning out gutters, blocked pipes and overflows as required,
- Pruning back vegetation close to or touching the building.

* Do not use a water blaster to wash down the soffits.

**Refer to your paint manufacturer for washing down and recoating requirements related to paint performance.

Product Warranties

James Hardie®
EAVES AND SOFFITS

February 2013

All James Hardie eaves and soffit linings come with a 15 year product warranty. Pre-finished products such as Eclipsa Eaves Lining and Silkline Soffit Lining come with a 10 year coating warranty and 15 year warranty on the base sheet. All accessories supplied by James Hardie are warranted for a period of 15 years. For full warranty details visit www.jameshardie.co.nz or Ask James Hardie on 0800 808 868.

Disclaimer: The recommendations in James Hardie's literature are based on good building practice, but are not an exhaustive statement of all relevant information and are subject to conditions (c), (d), (f) and (g) in each products warranty under "Conditions of Warranty". James Hardie has tested the performance of the Eclipsa™ Eaves Lining, HardieGroove™ Soffit Lining, Silkline® Soffit Lining, Villaboard® Soffit Lining, Hardiesoffit™ Lining and HardieFlex™ Eaves when installed in accordance with the Eclipsa™ Eaves Lining, HardieGroove™ Soffit Lining, Silkline® Soffit Lining, Villaboard® Soffit Lining, Hardiesoffit™ Lining and HardieFlex™ Eaves Lining installation manual, in accordance with the standards and verification methods required by the New Zealand Building Code (NZBC) and those test results demonstrate the product complies with the performance criteria established by the NZBC. However, as the successful performance of the relevant system depends on numerous factors outside the control of James Hardie (e.g. quality of workmanship and design) James Hardie shall not be liable for the recommendations made in its literature and the performance of the relevant system, including its suitability for any purpose or ability to satisfy the relevant provisions of the NZBC, regulations and standards, as it is the responsibility of the building designer to ensure that the details and recommendations provided in the relevant James Hardie installation manual are suitable for the intended project and that specific design is conducted where appropriate.

Ask James Hardie™
Call 0800 808 868
www.jameshardie.co.nz





Ask James Hardie™

Call 0800 808 868

www.jameshardie.co.nz