







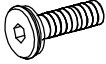
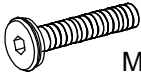

# SILVERLEAVES 3 PCE RESIN WICKER BENCH SETTING

## Assembly Instruction

Item number:3192437

A	 Table leg	1
B	 Table frame	2
C	 Support Bracket	4
D	 M6x20	16
E	 M6x35	4
F	 Bolt cover	16
G	 Washer	20
H	 Allen Key	1
I	 Glass	1

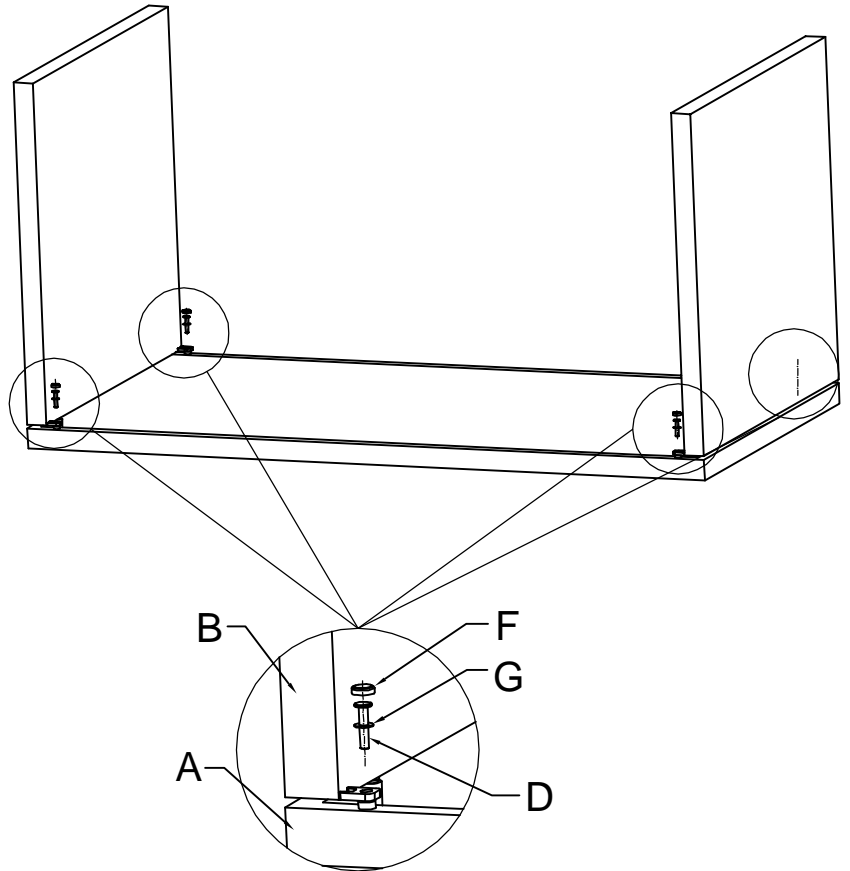

Step 1: Secure the table frame (B) to the table legs (A), using the bolt (D), washer (G), bolt cover (F) and Allen key (H). Repeat for each leg.

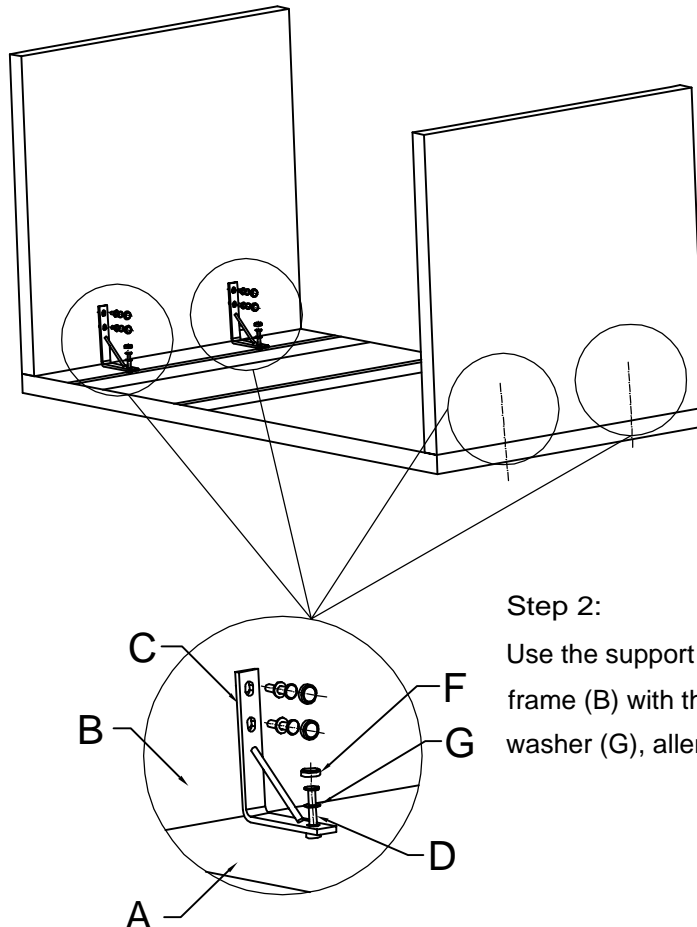

Step 2:

Use the support bracket (C) to secure the table frame (B) with the table legs (A), using bolt (D), washer (G), allen key (H) and bolt cover (F).

Step 3: Use scissors to carefully cut and remove the strapping securing the glass in place.

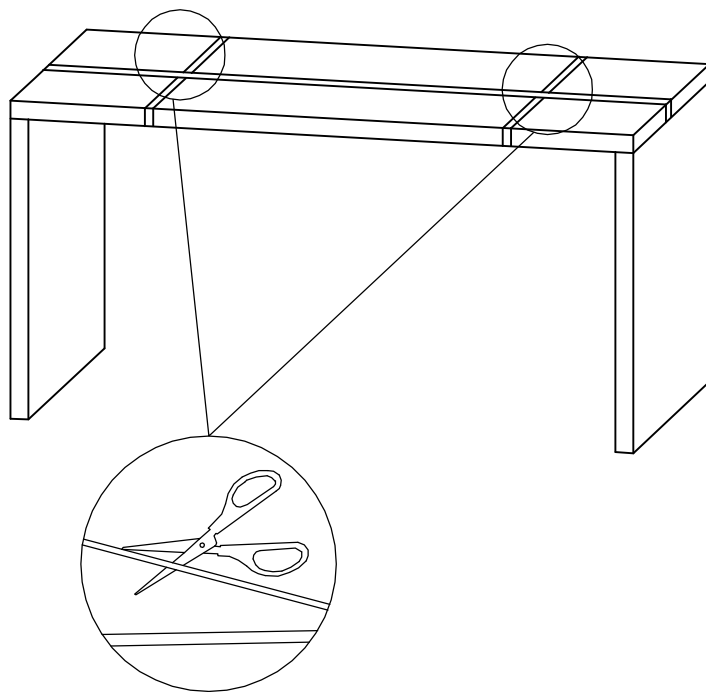

Step 4: Carefully lift the glass top and place on a clean protected surface.

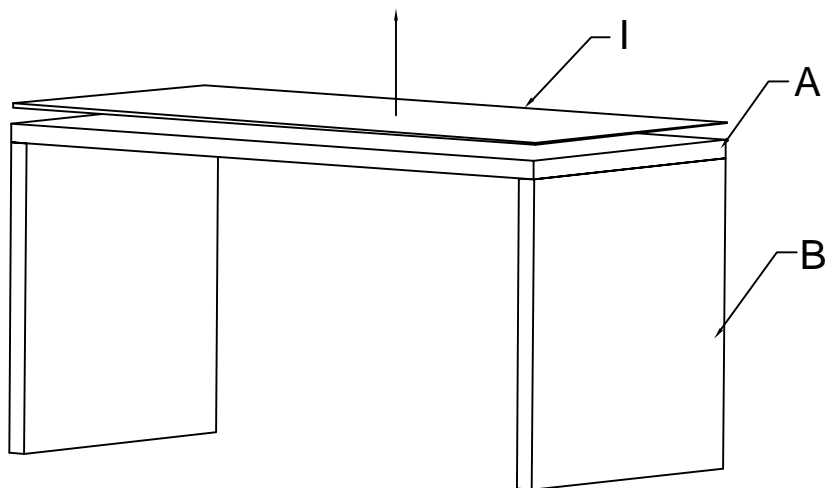

**Step 5:**

Using the bolt(E) ,washer(G) with the shaft sleeve,secure with the table frame(A)and leg frame(B),and using the allen key (H).

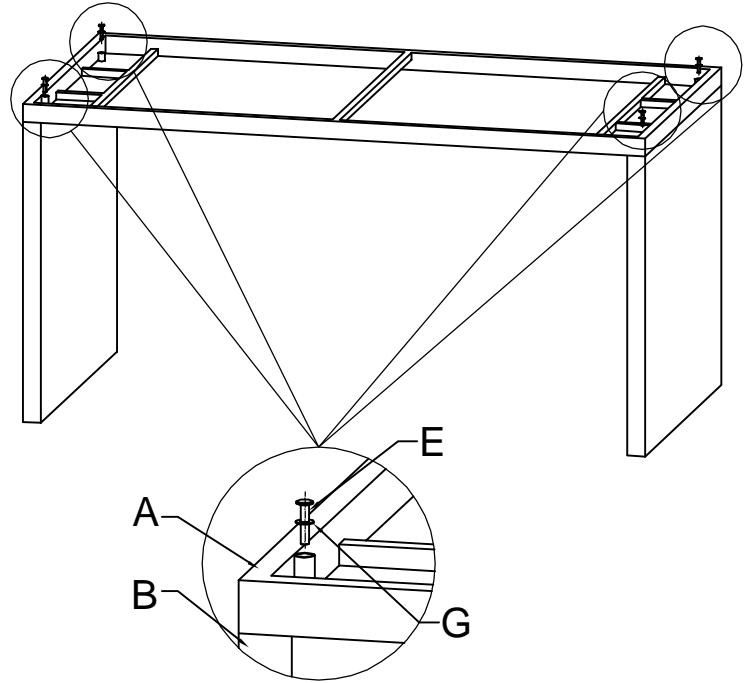

**Step 6:** Carefully replace the glass (I) back on top of the table frame (A).

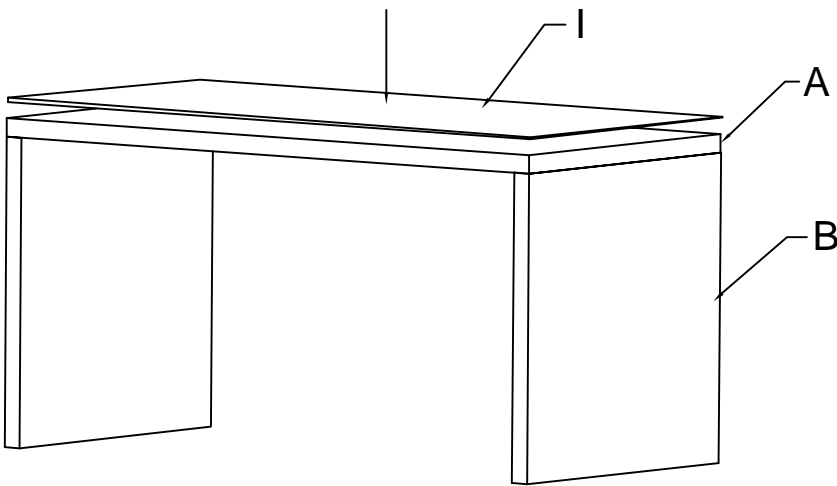



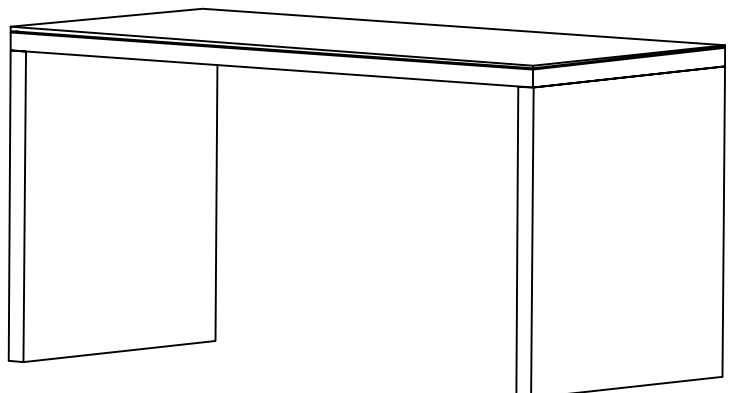



**Step 7:** Your table is now fully assembled and ready for use.

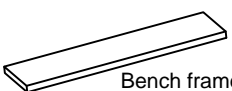
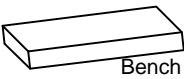

**Important Notice:**

Do not fully tighten bolts until the table is fully assembled.



A	 Bench frame	1
B	 Bench leg	2
C	 Support bracket	2
D	 M6x20	10
E	 Washer	10
F	 Bolt cover	10
G	 Allen key	1
H	 Adjusting knob	4

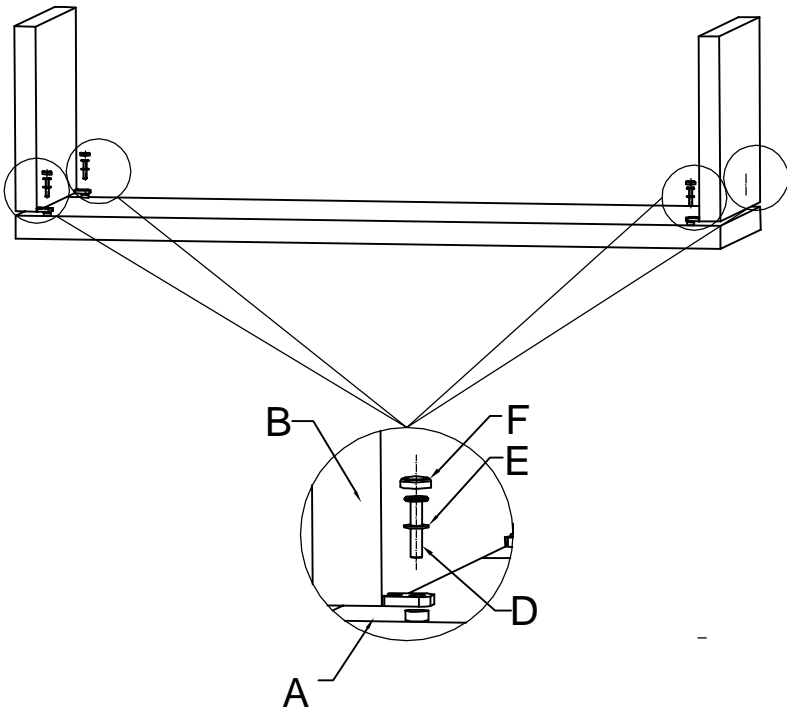

Step 1: Secure the bench frame (A) to the bench legs (B), using bolt (D), washer (E), bolt cover (F) and allen key (G). Repeat for the other leg.

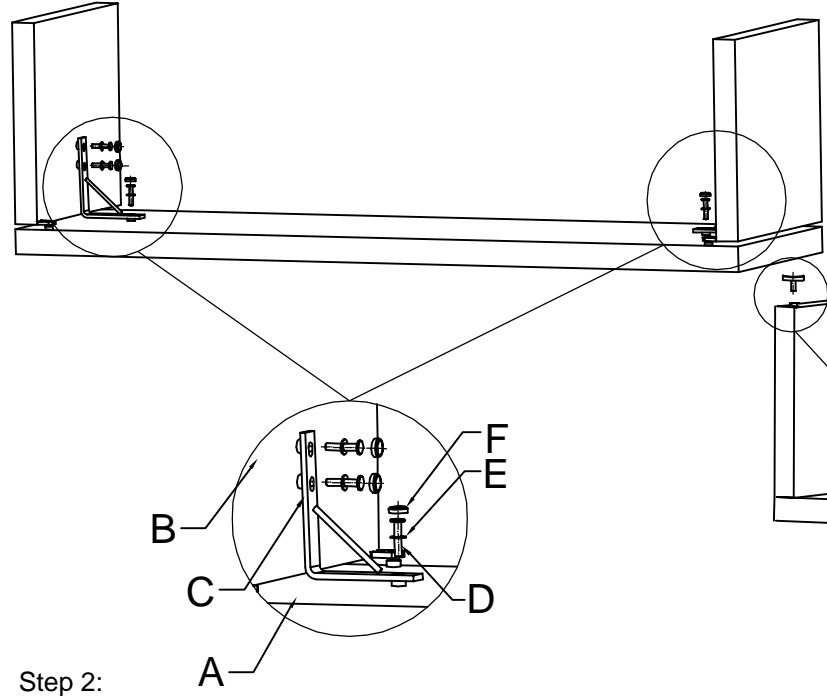

Step 2: Use the support bracket (C) to secure the bench frame (A) to the bench legs (B), using bolt (D), washer (E), Allen key (H) and bolt cover (F).

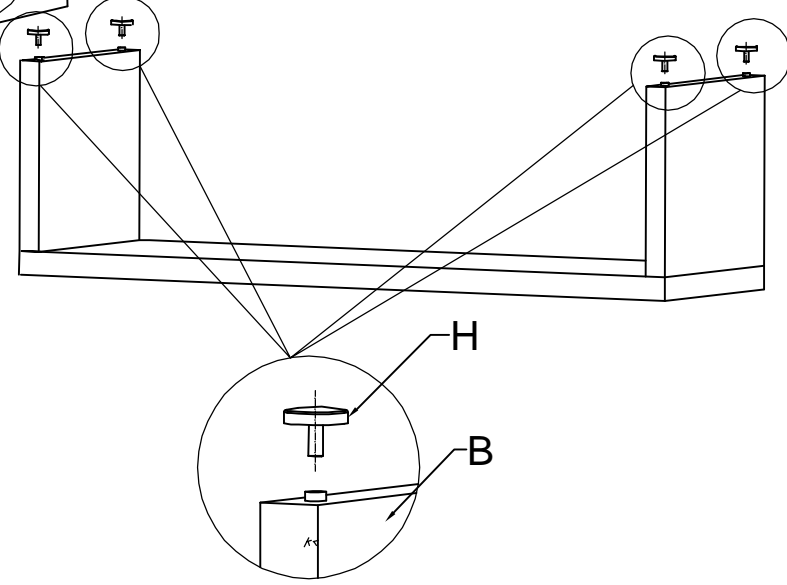

Step 3: Insert the adjusting knob (H) into the bench leg (B).

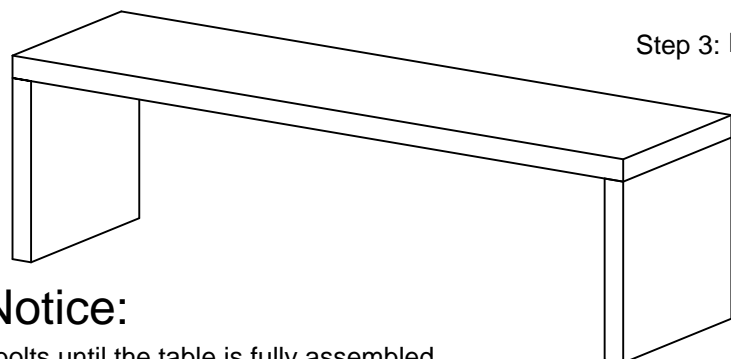

Step 4: Your bench is now ready for use.

**Important Notice:**

Do not fully tighten bolts until the table is fully assembled.